

REVISIONS					
P	LTR	DESCRIPTION	DATE	DWN	APVD
K		REVISED PER ECR-22-152397	06OCT2022	BB	DSC

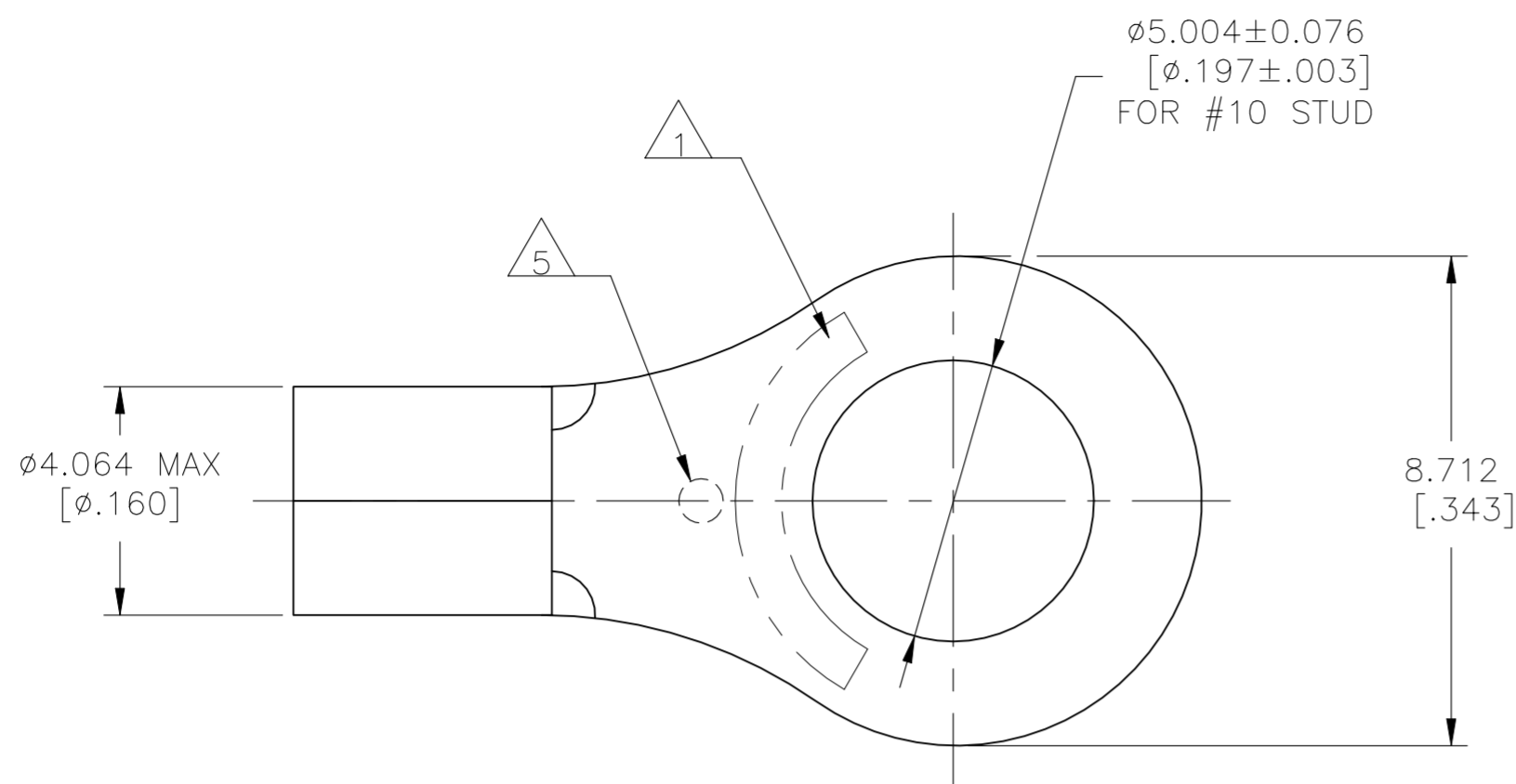

AMP WIRE RANGE	Listed FILE E13288	LR7189 Certified
16-14 AWG STRANDED	16-14 AWG STRANDED	NOT CERTIFIED

- 1 STAMP AMP 16-14* APPROX AS SHOWN
- 2 MATERIAL: COPPER PER ASTM B152
- 3 FINISH: TIN PLATE 0.00254[.000100] MIN EXT THK PER ASTM B545
- 4 BODY MATERIAL THK: 0.787±0.051[.031±.002]
- 5 "O" STAMP MARK OPTIONAL

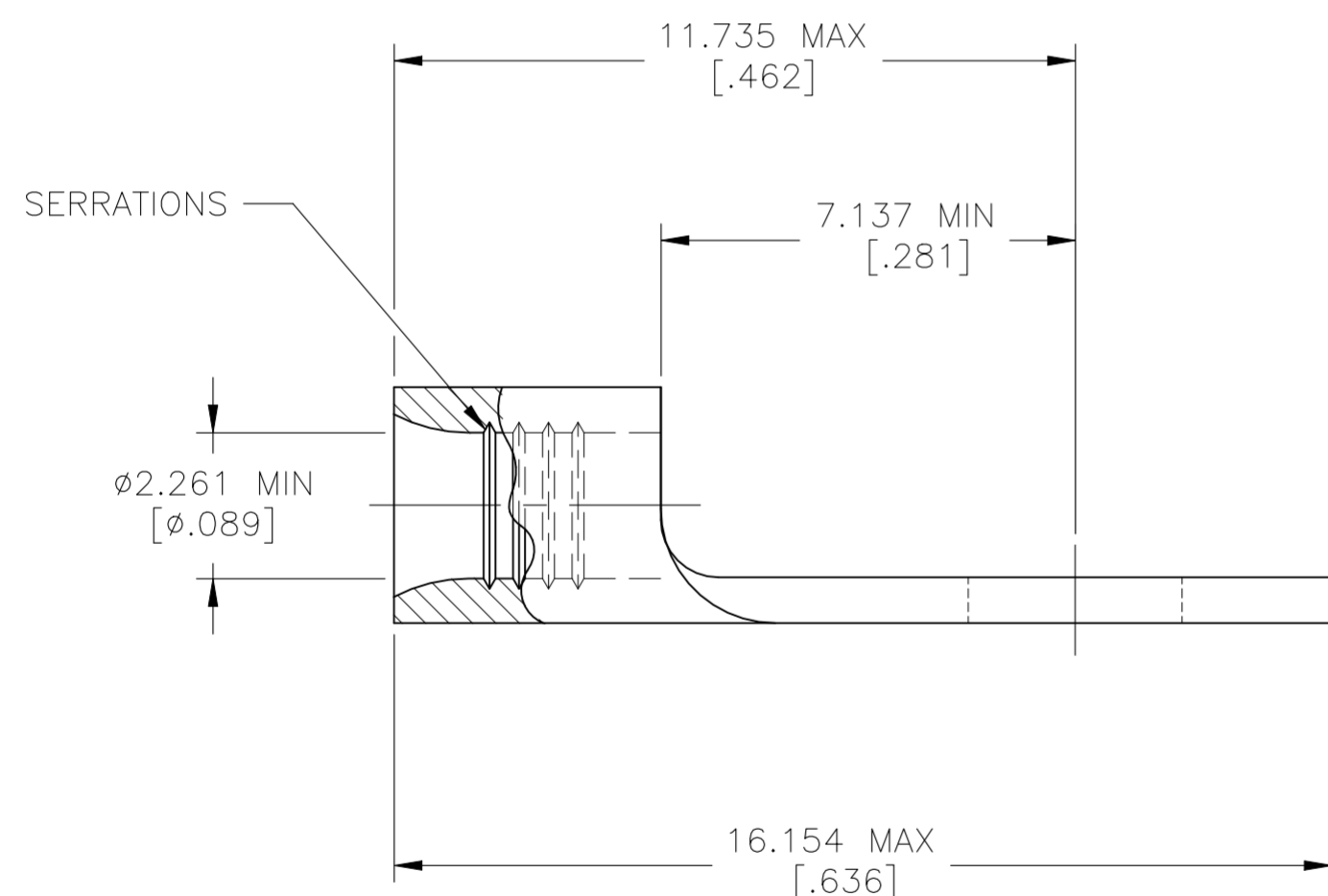

1000	LOOSE PIECE	30697
QTY	PACKAGE TYPE	PART NO.

AMP INCORPORATED CUSTOMER SERVICE SYSTEMS		MAX RECOMMENDED OPERATING TEMPERATURE: 170°C[338°F] MAX
FOR ADDITIONAL PRODUCT INFORMATION OR COPIES OF DRAWINGS AND TECHNICAL DOCUMENTS	PRODUCT INFORMATION CENTER 1-800-522-6752	VOLTAGE RATING: N/A
FOR APPLICATION TOOLING INFORMATION	TOOLING ASSISTANCE CENTER 1-800-722-1111	CIRCULAR MIL AREA: 1.04-2.62mm² [2,050-5,180] STRANDED
FOR ORDER ENTRY	1-800-526-5142	THIS DRAWING IS A CONTROLLED DOCUMENT FOR AMP INCORPORATED. IT IS SUBJECT TO CHANGE AND THE CONTROLLING ENGINEERING ORGANIZATION SHOULD BE CONTACTED FOR THE LATEST REVISION.

THIS DRAWING IS A CONTROLLED DOCUMENT.		DWN TA BRINKMAN 2-4-93
DIMENSIONS: mm [INCHES]		CHK DA PATTERSON 2-4-93
TOLERANCES UNLESS OTHERWISE SPECIFIED:		APVD JL MECKLEY 2-4-93
0 PLC ± -		PRODUCT SPEC UL486A-B
1 PLC ± -		APPLICATION SPEC
2 PLC ± -		WEIGHT -
3 PLC ± 0.127[.005]		SIZE A2
4 PLC ± -		CAGE CODE 00779
ANGLES ± -		DRAWING NO C=30697
MATERIAL 2	FINISH 3	RESTRICTED TO -

TE TE Connectivity		NAME	TERMINAL, RING TONGUE, BUDGET, WIRE SIZE: 16-14 AWG
SCALE 8:1	SHEET 1 of 1	REV K	