

REV	ECN	APP'D
G	5910	
H	6248	<i>[Signature]</i> 7/30/08

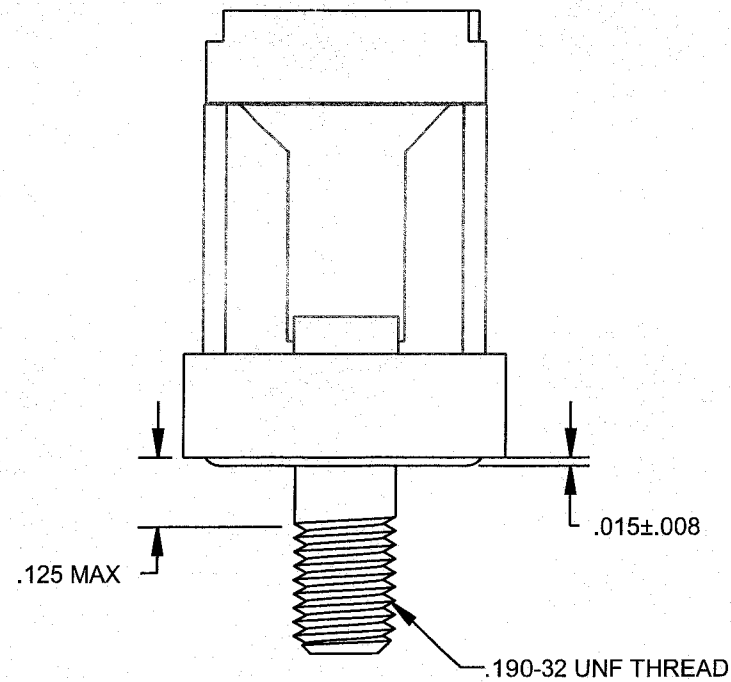
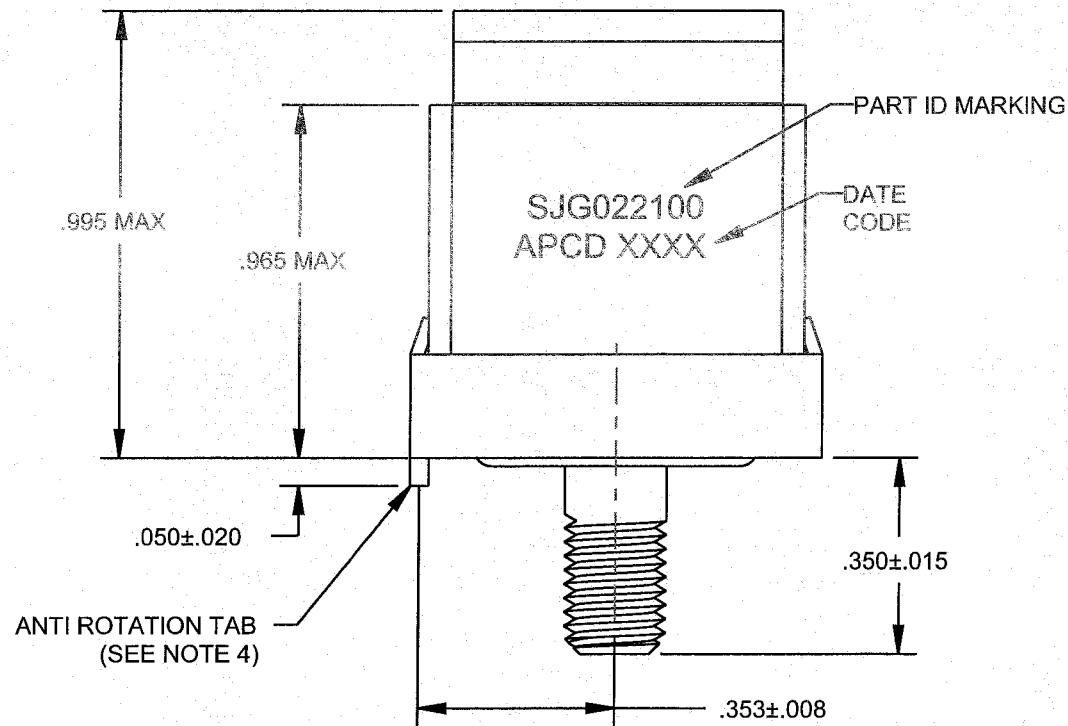
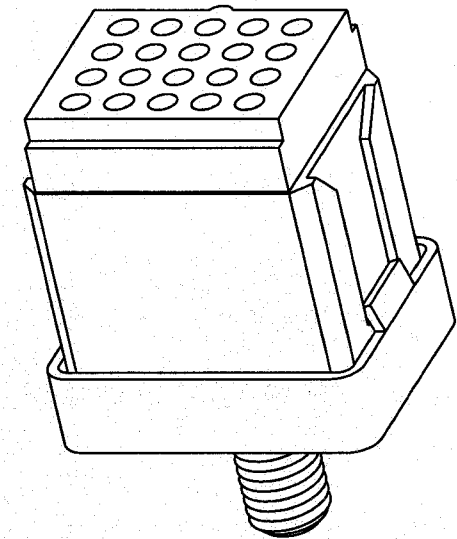
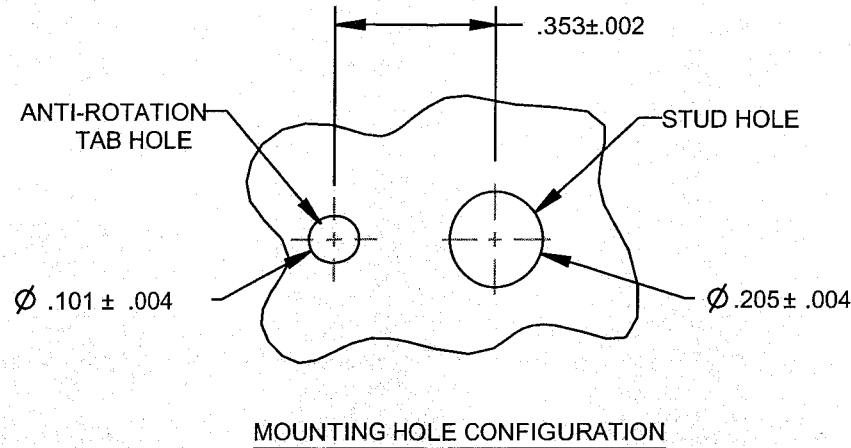
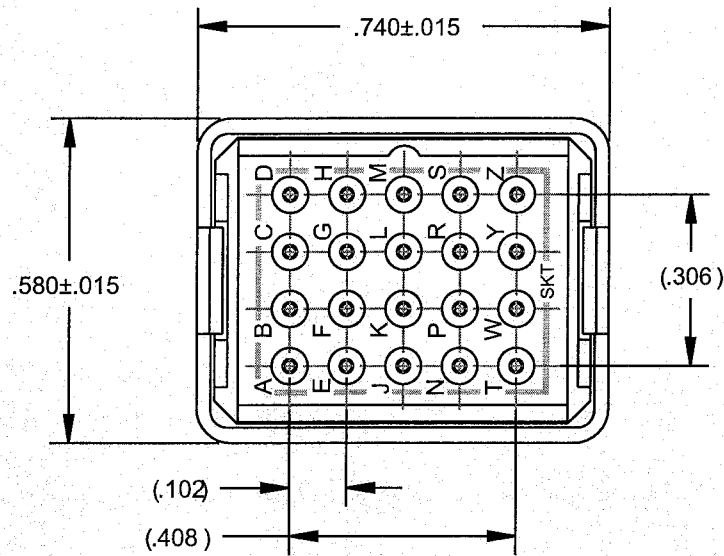

- NOTES:
- MATERIALS:
 BODY: POLYETHERIMIDE PER ASTM-D5205.
 GROMMET: SILICONE BLEND ELASTOMER PER A-A-59588.
 CONTACT RETAINERS: STAINLESS STEEL.
 SHELL/STUD: COPPER ALLOY, TIN PER MIL-T-10727, TYPE 1
 MOUNTING HARDWARE: (SUPPLIED SEPARATELY)
 STEEL, CADMIUM FINISH PER SAE-AMS-QQ-P-416
 - PERFORMANCE SPECIFICATIONS:
 MEETS ALL PERFORMANCE REQUIREMENTS OF MIL-T-81714.
 - MODULE ACCEPTS M39029/22-191 CONTACTS AND MS27488-22-1 SEALING PLUGS. SEE TABLE
 - ANTI ROTATION TAB SHALL ENTER INTO MOUNTING HOLE.

APCD P/N	SUPPLIED		MARKING
	SKTS	PLUGS	APCD PART NO.
SJG022100	21	2	SJG022100
SJG022101	-	-	

HARDWARE / SOCKET CONTACT BOM		
APCD P/N	DESCRIPTION	QTY.
200001201	FLAT WASHER, #10	1
200008251	HEX NUT 10-32 CRS SJG	1
200008301	LOCK WASHER, INT TOOTH, #10	1
CNS070900	M39029/22-191 CONTACT SZ 20/20	13
CNA032404	SEALING PLUG, SZ 22	2

DIMENSIONS ANSI Y14.5M UNITS: INCHES Pro/E FILE	TOLERANCES .XX ± 0.01 .XXX ± 0.005 ANGLES ± 2.0°	PROJECTION 	Amphenol Pcd SPECIFICATION DRAWING DRWN R. SWAINE 9/26/06 ENGR <i>[Signature]</i> 7/30/08 APPD <i>[Signature]</i> 7/30/08		TITLE SJG, SIZE 22 GROUNDING MODULE TIN FINISH		
ORIGINAL 	THIS DOCUMENT CONTAINS PROPRIETARY INFORMATION WHICH IS THE CONFIDENTIAL PROPERTY OF AMPHENOL PCD, BEVERLY, MA		SIZE B	DWG NO. SJG022100	REV H		
			CODE: 58982	SCALE: 2:1	SHEET 1 OF 1		

SJG022100

SJG022100