

PART NUMBER	REV	FIRST USED
567943-1	A	854040-3

TERMINAL NAME: DYNAMIC D-3 ("L" SIZE)						
CONTACT	RECPT	VISIBLE	CRIMPING DATA			
175286-2	175196	PAD	CRIMP HEIGHT		WIRE SIZE	
175286-3		LTR	CRIMP HEIGHT		WIRE SIZE	
175286-5		A	.046 ± .002 [1.17 ± 0.05mm]	0.5mm ² OR 20		
5-175286-2		B	NOT		USED	
5-175286-3		C	.058 ± .002 [1.47 ± 0.05mm]	1.25mm ² OR 16		
5-175286-5		D	.051 ± .002 [1.30 ± 0.05mm]	0.85mm ² OR 18		
CRIMP	SIZE	TYPE	RANGE			
WIRE	.090 [2.29mm]	F	0.5mm ² - 1.25mm ²			
INSUL	.110 [2.79mm]	F	ø1.8mm - ø2.8mm			
WIRE STRIP LENGTH	TERM APPL SPEC	FEED	APPL INSTRUCTION	SET UP GAGE	LAYOUT	
.141 - .172	114-5148	.512	SEE CUSTOMER MANUAL	NONE	L1497Q	

SIM TO HDM 567496

QTY	REV	TER	APPL	SPEC	FEED	APPL INSTRUCTION	SET UP GAGE	LAYOUT	ITEM NO
2	-	C			4-354779-5	PIN, WIRE DISC (.3215)C			129
2	-	C			3-354779-4	PIN, WIRE DISC (.3160)B			128
2	-	C			2-354779-0	PIN, WIRE DISC (.3090)A			126
1	-	A			986950-1	WASHER, FLAT PRECISION			125
1	-	A			217238-3	GENERAL INSTRUCTION PACKAGE			124
									123
									122
1	-	A			4-21028-0	PIN, SLT SPR (ø.093x.75) ST GDE PL			121
1	-	B			690701-2	PLATE, SERIAL NO.			120
2	-	A			21899-2	WASHER, FLAT (#10) S G ADJ BLK			119
									118
2	-	A			21024-5	WASHER, LOCK (#10) ADJ BLOCK			117
									116
									115
2	-	A			21024-2	WASHER, LOCK (#4) FRONT STP GUIDE			114
REF	-	A			21024-4	WASHER, LOCK (#8) FEED FINGER			113
2	-	A			21024-4	WASHER, LOCK (#8) DEP-HOLD			112
REF	-	A			21024-4	WASHER, LOCK (#8) STRIPPER			111
									110
									109
1	-	A			21018-5	NUT, HEX (#6) HOLD DOWN			108
									107
									106
									105
									104
1	-	A			21009-2	SCR, SKT SET (1/4-20x.25 LW) RAM			103
									102
4	-	A			21017-2	SCR, DRIVE (#2x.19) ID PLATE			101
1	-	B			819347-1	PLATE, IDENTIFICATION			100
2	-	A			3-21002-0	SCR, BHC (10-32x.88) DRAG			99
1	-	A			22733-8	SCR, BHC (8-32x.38 LW) ANVIL			98
									97
1	-	A			3-21000-8	SCR, SHC (10-32x.88) MOUNTING			96
1	-	A			2-21002-7	SCR, BHC (10-32x.50) SG ADJ BLK			95
6	-	A			2-21002-2	SCR, BHC (8-32x.50) SHEAR-TERM SUP			94
									93
									92
1	-	A			1-21002-7	SCR, SHC (6-32x.50) CAM			91
4	-	A			2-21000-7	SCR, SHC (8-32x.50) SCR BLK			90
									89
									88
									87
REF	-	A			2-22603-0	SCR, HEX HD (8-32x.31) FEED FINGER			86
2	-	A			1-21000-3	SCR, SHC (4-40x.25) F ST GUIDE			85
REF	-	A			22733-9	SCR, BHC (8-32x.50 SL) STRIPPER			84
									83
									82
1	-	A			3-22603-1	SCR, HEX (10-32x.38) SG ADJ BL			81
									80
									79
									78
2	-	B			463310-4	BLADE, STRIPPING (#18)			77
									76
									75
1	-	A			690603-1	SPRING, ASSIST			74
1	-	A			23030-1	SCR, SKT CAP (6-32x.25) CP DSC			73
									72
									71

QTY REQD PER ASSY	U/M	DWG SIZE	PART NO	DESCRIPTION	ITEM NO
PARTS LIST					

QTY REQD PER ASSY	U/M	DWG SIZE	PART NO	DESCRIPTION	ITEM NO
PARTS LIST					

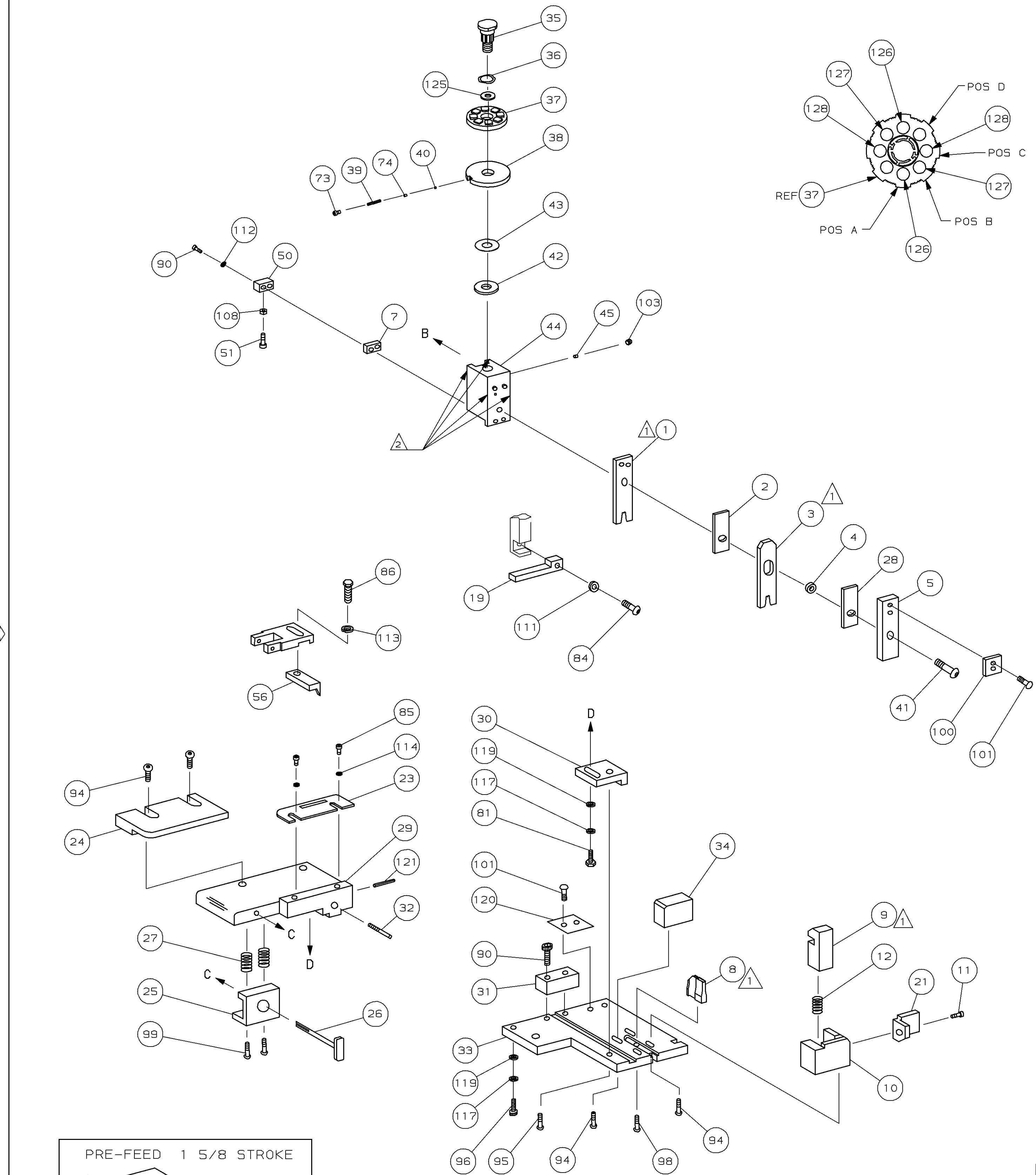

- 1 RECOMMENDED SPARE PARTS.
- 2 GREASE LIGHTLY.
- 3 ITEM NOT SHOWN

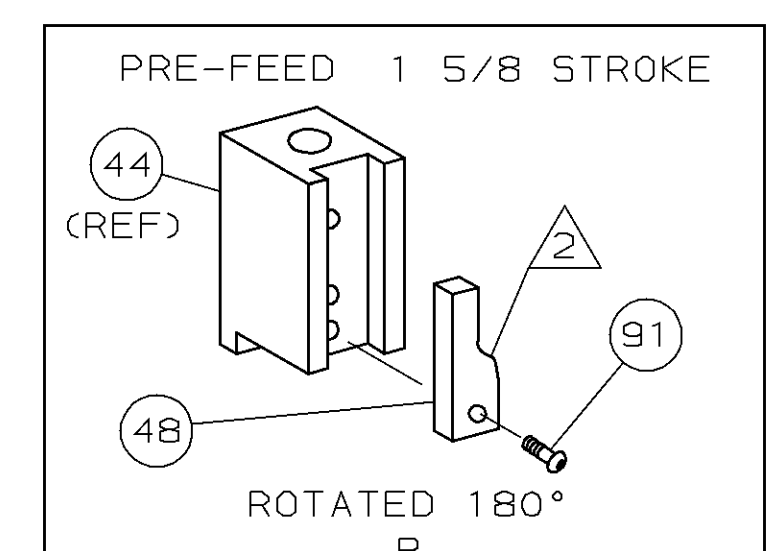

DIMENSIONS IN INCHES. DO NOT SCALE PRINT. TOLERANCES UNLESS OTHERWISE SPECIFIED.

2 PLC DEC ±
3 PLC DEC ±
4 PLC DEC ±
ANGLES ±
SURF TEXTURE: ✓
REMOVE BURRS, BREAK SHARP EDGES R.015 MAX

MATL	-	HT TR	-	FIN	-
DR	03SEP97	APP	03SEP97	AMP Incorporated Harrisburg, PA 17105-3608	
M. OBRINE	J. HIRNEISEN	REL	-	AMP Incorporated Harrisburg, PA 17105-3608	
CHK 03SEP97	C. ERISMAN	REL	-	AMP Incorporated Harrisburg, PA 17105-3608	
NAME				STRIPPER CRIMPER APPLICATOR	
SCALE				DWG NO 567943	
MACHINE REF				STRIPPER CRIMPER	
SHEET				REV 1 OF 1 A	

THIS DRAWING IS A CONTROLLED DOCUMENT FOR AMP INCORPORATED. IT IS SUBJECT TO CHANGE AND THE CONTROLLING ENGINEERING ORGANIZATION SHOULD BE CONTACTED FOR THE LATEST REVISION.

THIS INFORMATION IS CONFIDENTIAL AND IS DISCLOSED TO YOU ON CONDITION THAT NO FURTHER DISCLOSURE IS MADE BY YOU TO OTHER THAN AMP PERSONNEL WITHOUT WRITTEN AUTHORIZATION FROM AMP INCORPORATED, HARRISBURG, PA.

LOC A
DIST 66

567943