

THIS DRAWING IS UNPUBLISHED. RELEASED FOR PUBLICATION
 © COPYRIGHT BY TYCO ELECTRONICS CORPORATION. ALL RIGHTS RESERVED.

DESIGNED FOR USE WITH RG-142/U CABLE	
CABLE ENTRY DIAMETER MINIMUM	
HOUSING	.119
CONTACT	.040
FERRULE	.216

LOC	DIST	REVISIONS					
AJ	00	P	LTR	DESCRIPTION	DATE	DWN	APVD
		B		REV PER ECO 07-004710	3/12/2007	DW	KW

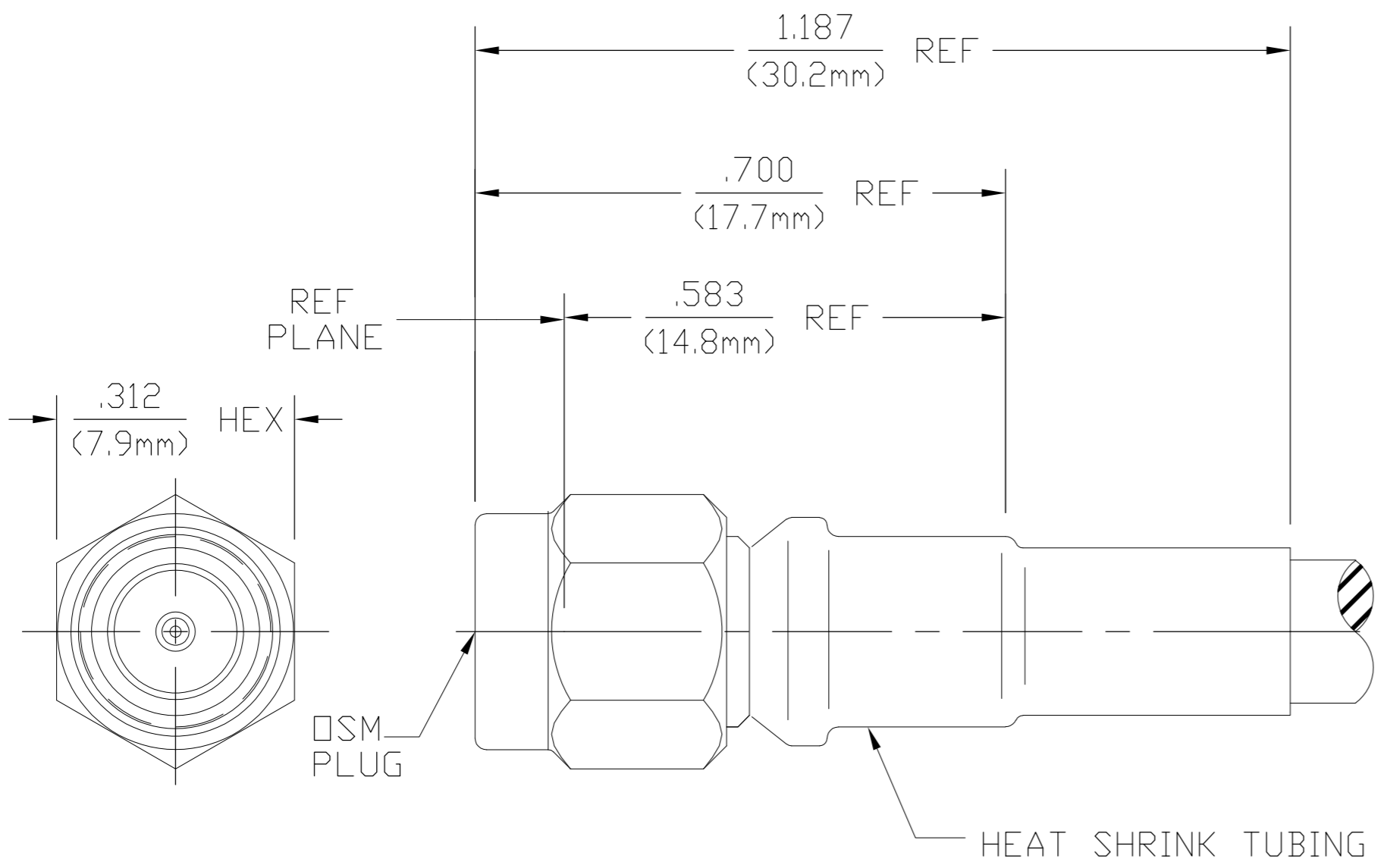

1051651-1
PART
NUMBER

HOUSING COUPLING NUT	STAINLESS STEEL PER ASTM-A484 AND ASTM-	PASSIVATE PER ASTM-A380
DIELECTRIC	TFE FLUOROCARBON PER ASTM-D-1457	N/A
CENTER CONTACT	BERYLLIUM COPPER PER ASTM B 196, ALLOY C17300, CONDITION H OR BRASS PER ASTM-B-16	GOLD PLATE PER MIL-G-45204 OVER COPPER PLATE PER MIL-C-14550
RETAINING RING	BERYLLIUM COPPER PER ASTM B 194, ALLOY C17200, CONDITION H	N/A
GASKET	SILICONE RUBBER PER ZZ-R-765	N/A
SHRINK TUBING	HEAT SHRINKABLE POLYOLEFIN COMPOUND MIL-I-23053/4	N/A
FERRULE	COPPER OR BRASS ALLOY ROCKWELL F65 MAXIMUM	GOLD PLATE PER MIL-G-45204 OVER COPPER PLATE PER MIL-C-14550
COMPONENT	MATERIAL	FINISH

ELECTRICAL	MECHANICAL	ENVIRONMENTAL
Nominal Impedance (Ohms) <u>50</u>	Interface Dimensions MIL-STD-348A, Fig. <u>310.1</u>	TEMPERATURE RATING <u>-62°C TO +165°C</u>
Frequency Range (GHz) DC to <u>12.4</u>	Recommended Mating Torque <u>7 to 10 in-lbs</u>	Vibration MIL-STD-202, Method 204, Condition D.
Volt Rating (VRMS MAX) @ Sea Level <u>335</u>	Mating Characteristics: Insertion (MAX Lbs) <u>N/A</u>	Shock MIL-STD-202, Method 213, Cond I
VSWR <u>1.15 +.01 f(GHz)</u>	Withdrawal (MIN Oz) <u>N/A</u>	Thermal Shock MIL-STD-202, Method 107, Condition B, EXCEPT HIGH TEMP SHALL BE +85°C
Insertion Loss (dB MAX) <u>.06 √f(GHz)</u>	Force to Engage and Disengage (In-Lbs MAX) <u>2.0</u>	Moisture Resistance MIL-STD-202, Method 106
RF Leakage (dB MIN) <u>-[60-f(GHz)]</u>	Center Contact Captivation Axial (Lbs) <u>N/A</u>	Corrosion - MIL-STD-202, Method 101, Condition B, 5% salt spray
Corona, 70,000Ft (VRMS MIN) <u>250</u>	Radial (In-Oz) <u>N/A</u>	
Dielectric Withstanding Voltage (VRMS MIN) @ Sea Level <u>1,000</u>	Cable to Housing Retention (lbs MIN) <u>45</u>	
Contact Resistance (Milliohms MAX) Center Contact <u>2.0</u>	Weight (Grams) <u>TBD</u>	
Outer Contact <u>2.0</u>		
Cable to Housing <u>0.5</u>		
RF High Potential @ Sea Level (VRMS MIN @ 5 MHz) <u>670</u>		
I.R.(Megohms MIN) <u>10,000</u>		

THIS DRAWING IS A CONTROLLED DOCUMENT.

DWN	E.J.C	2/21/68
CHK	PRB	2/22/68
APVD	D NANIA	2/23/68

tyco Electronics Tyco Electronics Corporation Harrisburg, PA 17105-3608

OSM STRAIGHT CABLE PLUG CRIMP ATTACHMENT

SIZE	A2	CAGE CODE	00779	DRAWING NO	1051651	RESTRICTED TO	-
WEIGHT	-	SCALE	4:1	SHEET	1 of 1	REV	B

CUSTOMER DRAWING