

PIEZOELECTRIC INVERTER 1.0W/3.6V/500VAC/2mA

1. Scope

This applies to the CFL Inverter (cold-cathode tube inverter) HBL-0204.

2. Electrical Characteristics

a. Absolute Maximum Rating

Input voltage	6.5V MAX.
Max. output power	1.0W MAX.

b. Input/Output Characteristics

The measuring circuit and measuring method shall be as set forth in Section 3.
(Unless otherwise specified, $T_a = 25^\circ\text{C}$)

Values are those obtained 3 minutes after the power is turned on.

Item	Specification
Input Voltage	3.0V ~ 5.5V
Rated tube current	2.0mA _{rms} ± 10%
Frequency	160KHz ± 10%
Output open voltage	900V _{rms} min (at ambient temperature 0°C)
Input current	350mA MAX (V _{in} = 3.0V Equivalent load resistance 380KΩ)
ON/OFF function	ON: ON/OFF terminal signal HIGH (2.5V ~ 5.5V) OFF: ON/OFF terminal signal LOW (0.7V MAX) (To turn on the inverter, apply voltage to the V _{in} terminal, then turn on the ON/OFF terminal.)
V _{cc} voltage	5.0V ± 5%
V _{cc} current	15mA MAX.

c. Dimming

To use the dimming function, apply the following signal to the ON/OFF terminal, with a Duty rate of 20% ~ 95%.

No Dimming function with 100% Duty rate (always High)

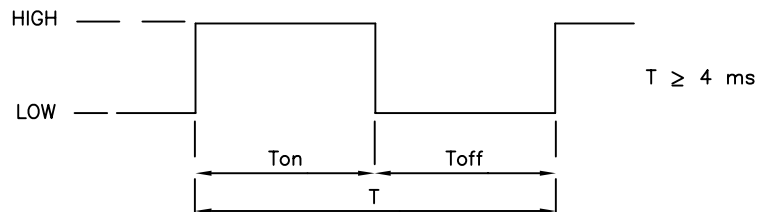

FILE NAME: ACAD\MXFMR\A3121961.DWG	SCALE: NONE	REV: D	DATE: 11/27/00	SHEET 1 OF 5
TAMURA CORPORATION OF AMERICA 43352 BUSINESS PARK DRIVE • TEMECULA • CA • 92590 TEL: (909)699-1270 • FAX: 9096769482	TITLE:	PIEZOELECTRIC INVERTER		
		HBL-0204	1.0W/3.6V/500VAC/2mA	
DOCUMENT NUMBER:		P-A3-12196		

CONTENTS OF THIS DRAWING ARE SUBJECT TO CHANGE WITHOUT PRIOR NOTICE

PROPRIETY NOTICE: THIS DRAWING PRINT OR DOCUMENT AND SUBJECT MATTER DISCLOSED HEREIN ARE PROPRIETARY ITEMS TO WHICH TAMURA RETAINS THE EXCLUSIVE RIGHT OF DISSEMINATION, REPRODUCTION, MANUFACTURE AND SALE. THIS DRAWING, PRINT OR DOCUMENT IS SUBMITTED IN CONFIDENCE FOR CONSIDERATION BY THE RECIPIENT ALONE UNLESS PERMISSION FOR FURTHER DISCLOSURE IS EXPRESSLY GRANTED IN WRITING.

- d. Standby Current
 $5\mu\text{A}$ MAX @ ON/OFF terminal signal LOW, $V_{in}=3.0\text{V} \sim 5.5\text{V}$
- e. Input Sequence

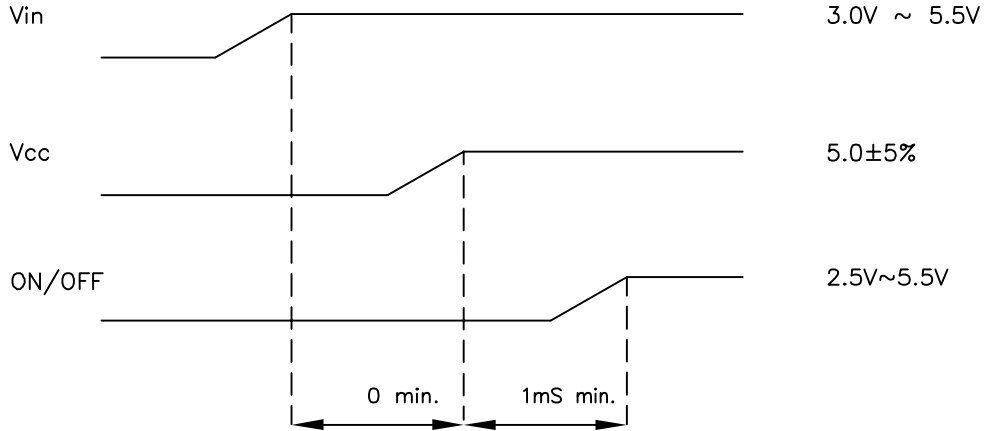

3. Measuring Circuit and Method for Electrical Characteristic

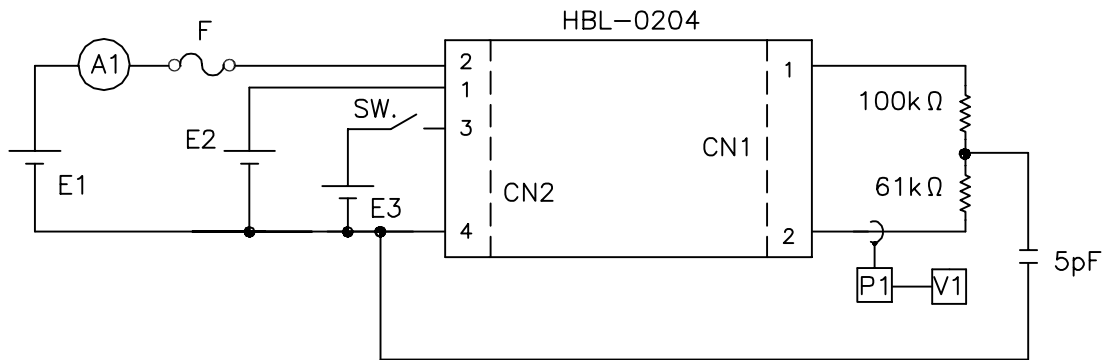

- | | |
|-------------------------------|---|
| E1: DC regulated power supply | $3.0\text{V} \sim 5.5\text{V}$ |
| E2: DC regulated power supply | $5.0\text{V}\pm 5\%$ |
| E3: DC regulated power supply | $2.5\text{V} \sim 5.5\text{V}$ |
| V1: RMS voltmeter | 3400B (YHP) or equivalent |
| A1: DC ammeter | Type 2011 Class 0.5 (YEW) or equivalent |
| P1: Probe | P6021 (Tektronix) or equivalent |
| F1: Fuse | CCP2E25 (KOA) |

FILE NAME: ACAD\MXFMR\A3121962.DWG	SCALE: NONE	REV: D	DATE: 11/27/00	SHEET 2 OF 5
TAMURA CORPORATION OF AMERICA 43352 BUSINESS PARK DRIVE • TEMECULA • CA • 92590 TEL: (909)699-1270 • FAX: 9096769482	TITLE: HBL-0204		PIEZOELECTRIC INVERTER	
	DOCUMENT NUMBER: P-A3-12196		1.0W/3.6V/500VAC/2mA	
CONTENTS OF THIS DRAWING ARE SUBJECT TO CHANGE WITHOUT PRIOR NOTICE				
PROPRIETY NOTICE: THIS DRAWING PRINT OR DOCUMENT AND SUBJECT MATTER DISCLOSED HEREIN ARE PROPRIETARY ITEMS TO WHICH TAMURA RETAINS THE EXCLUSIVE RIGHT OF DISSEMINATION, REPRODUCTION, MANUFACTURE AND SALE. THIS DRAWING, PRINT OR DOCUMENT IS SUBMITTED IN CONFIDENCE FOR CONSIDERATION BY THE RECIPIENT ALONE UNLESS PERMISSION FOR FURTHER DISCLOSURE IS EXPRESSLY GRANTED IN WRITING.				

4. Ambient Conditions

- a. Temperature
 Operating temperature: 0°C ~ 60°C
 Storage temperature: -20°C ~ 70°C
- b. Humidity
 Operating humidity: 20% ~ 80% (No condensation)
 Storage humidity: 5% ~ 90% (No condensation)

5. Reliability

The reliability is verified on the following items

Item	Specification
High temp. storage	Ambient temperature 70°C, 240H
Low temp. storage	Ambient temperature -20°C, 240H
High temp. and humidity storage	Ambient temperature 40°C, Humidity 95%, 240H
Temperature Cycle	-20°C ~ 70°C, 5 cycles
High temperature operation	Ambient temperature 60°C, input voltage 5.5V, output current 2.0Arms, 500H (Equivalent load resistance)
ON/OFF test	1 min:ON, 1min:OFF, 50000 times (Input voltage 5.5V, output current 2.0Arms, Equivalent load resistance)
Vibration	Acceleration 3G, frequency 10~ 55Hz, sweep 45 min. Once in each of X, Y, and Z directions.
Shock	Acceleration 80G, acting time 11ms, 3 times in each of X, Y, and Z directions.

After the end of each test, leave the product at room temperature and humidity for 24 hours. The Electrical and Mechanical characteristics shall remain within spec.

6. Precautions for static electricity

When transporting this product, use materials that will not develop an electrical charge. When handling this product, be sure to wear antistatic wrist bands or other protective equipment to prevent the product from being destroyed by any electric charge.

7. This inverter does not have a fuse.

FILE NAME: ACAD\MXFMR\A3121963.DWG	SCALE: NONE	REV: D	DATE: 11/27/00	SHEET 3 OF 5
TAMURA CORPORATION OF AMERICA 43352 BUSINESS PARK DRIVE • TEMECULA • CA • 92590 TEL: (909)699-1270 • FAX: 9096769482	TITLE: HBL-0204		PIEZOELECTRIC INVERTER 1.0W/3.6V/500VAC/2mA	
	DOCUMENT NUMBER:		P-A3-12196	
CONTENTS OF THIS DRAWING ARE SUBJECT TO CHANGE WITHOUT PRIOR NOTICE				
PROPRIETY NOTICE: THIS DRAWING PRINT OR DOCUMENT AND SUBJECT MATTER DISCLOSED HEREIN ARE PROPRIETARY ITEMS TO WHICH TAMURA RETAINS THE EXCLUSIVE RIGHT OF DISSEMINATION, REPRODUCTION, MANUFACTURE AND SALE. THIS DRAWING, PRINT OR DOCUMENT IS SUBMITTED IN CONFIDENCE FOR CONSIDERATION BY THE RECIPIENT ALONE UNLESS PERMISSION FOR FURTHER DISCLOSURE IS EXPRESSLY GRANTED IN WRITING.				

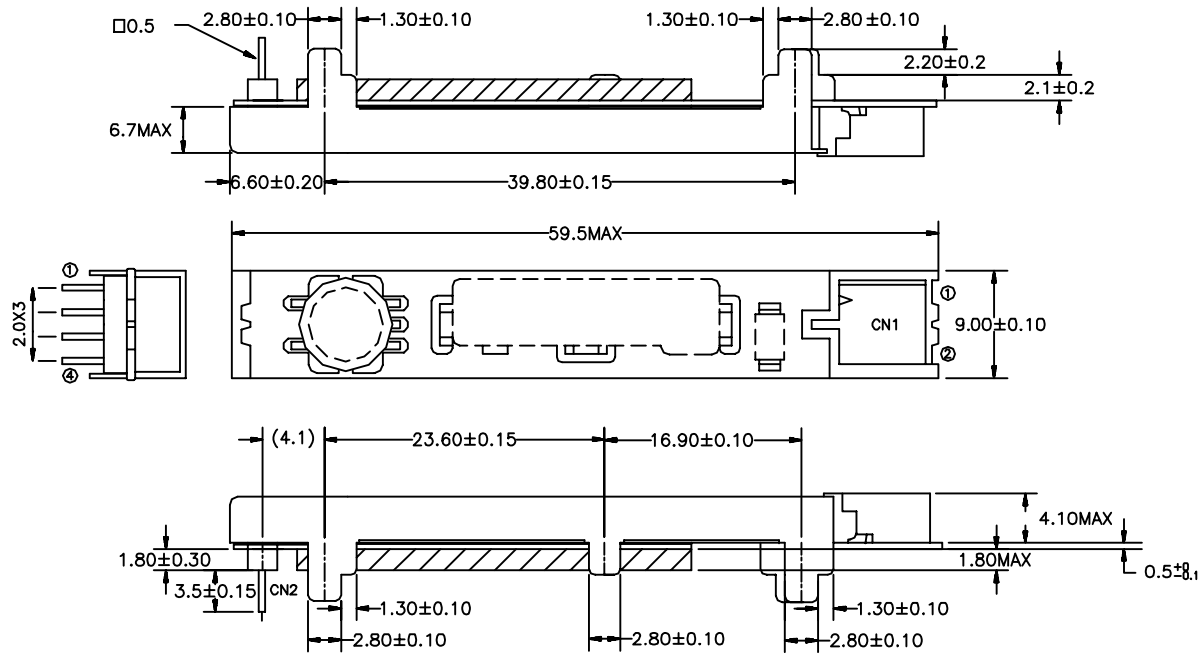

CN1: HV-2P-HF (JAE)

- ① High
- ② Low

Mating Connector: HV-2S-C1 (JAE)
IL-Z-C1-A-7000 (Contact)

CN2: A4B-4PA-2DSA (HRS)

- ① Vcc
- ② Vin
- ③ ON/OFF
- ④ GND

Through Hole Soldering

RECOMMENDED BOARD LAYOUT

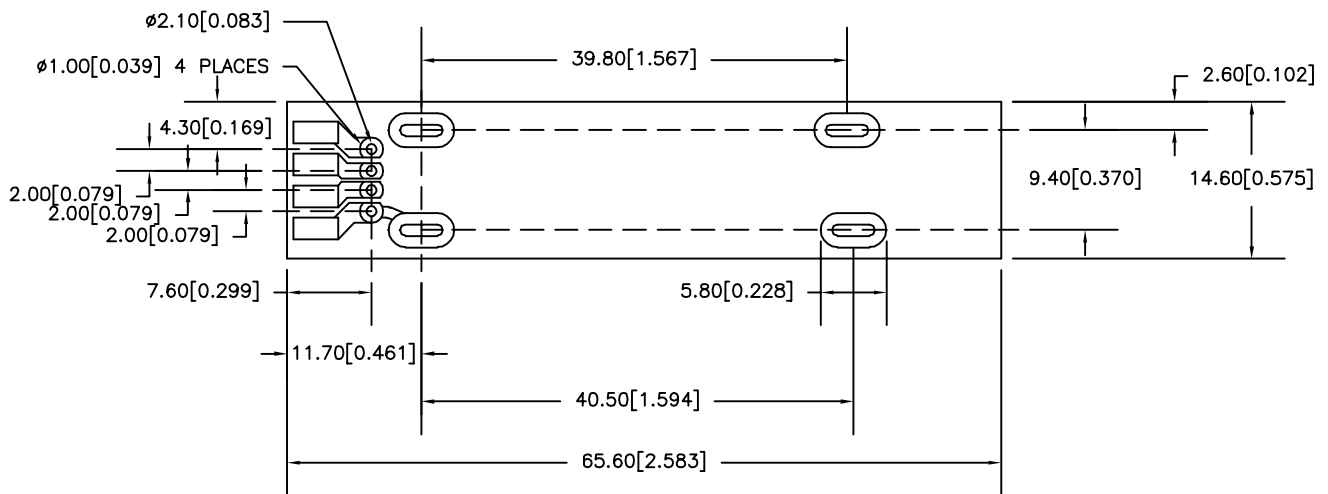

FILE NAME: ACAD\MXFMR\A3121964.DWG	SCALE: NONE	REV: D	DATE: 11/27/00	SHEET 4 OF 5
TAMURA CORPORATION OF AMERICA 43352 BUSINESS PARK DRIVE • TEMECULA • CA • 92590 TEL: (909)699-1270 • FAX: 9096769482	TITLE:	PIEZOELECTRIC INVERTER		
		HBL-0204 1.0W/3.6V/500VAC/2mA		
CONTENTS OF THIS DRAWING ARE SUBJECT TO CHANGE WITHOUT PRIOR NOTICE		DOCUMENT NUMBER:	P-A3-12196	
PROPRIETY NOTICE: THIS DRAWING PRINT OR DOCUMENT AND SUBJECT MATTER DISCLOSED HEREIN ARE PROPRIETARY ITEMS TO WHICH TAMURA RETAINS THE EXCLUSIVE RIGHT OF DISSEMINATION, REPRODUCTION, MANUFACTURE AND SALE. THIS DRAWING, PRINT OR DOCUMENT IS SUBMITTED IN CONFIDENCE FOR CONSIDERATION BY THE RECIPIENT ALONE UNLESS PERMISSION FOR FURTHER DISCLOSURE IS EXPRESSLY GRANTED IN WRITING.				

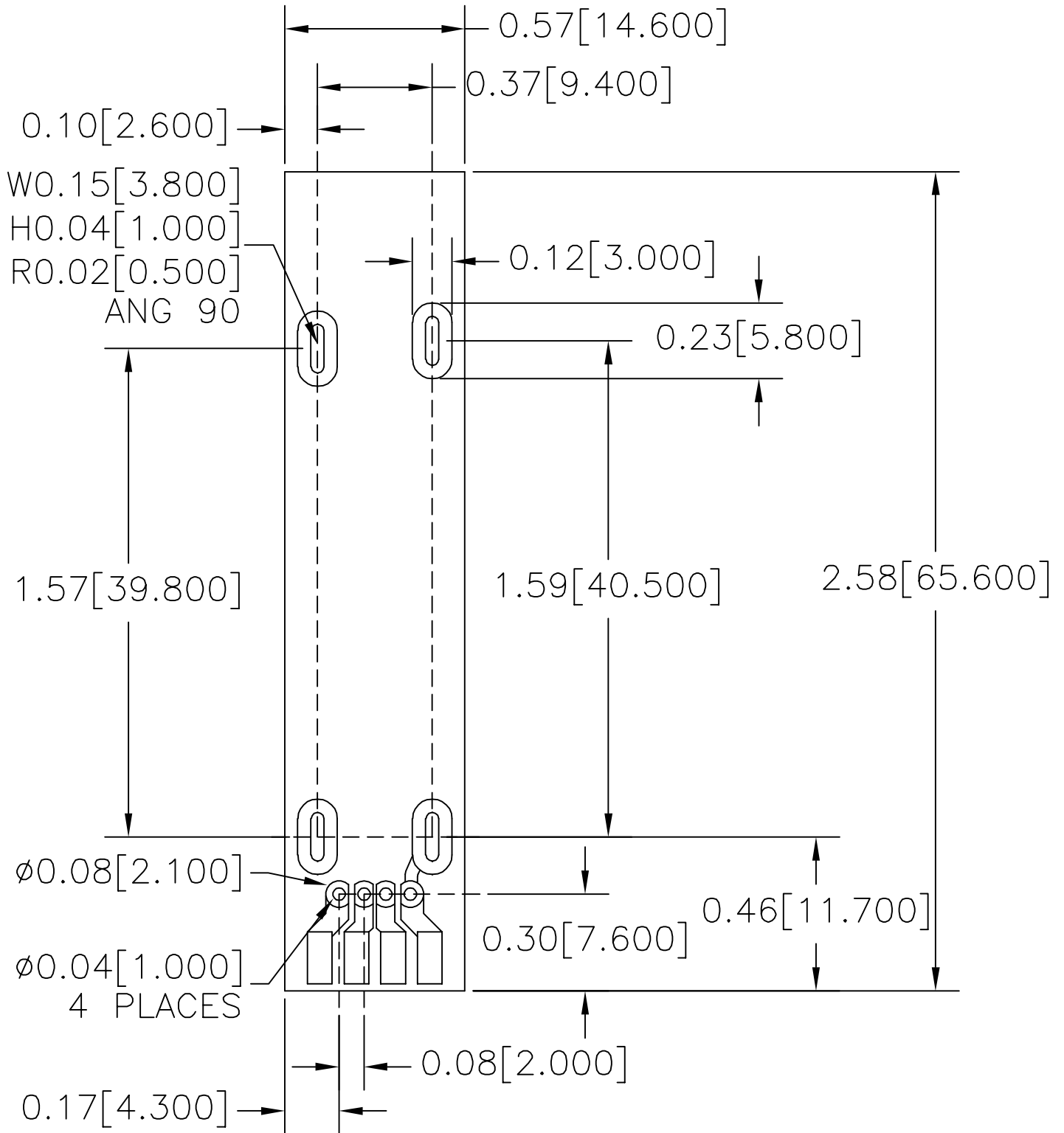

FILE NAME: ACAD\MXFMR\A3121964.DWG	SCALE: 4/1	REV: D	DATE: 11/27/00	SHEET 5 OF 5
TAMURA CORPORATION OF AMERICA 43352 BUSINESS PARK DRIVE • TEMECULA • CA • 92590 TEL: (909)699-1270 • FAX: 9096769482	TITLE:	PIEZOELECTRIC INVERTER		
		HBL-0204	1.0W/3.6V/500VAC/2mA	
DOCUMENT NUMBER:		P-A3-12196		
CONTENTS OF THIS DRAWING ARE SUBJECT TO CHANGE WITHOUT PRIOR NOTICE				
PROPRIETY NOTICE: THIS DRAWING PRINT OR DOCUMENT AND SUBJECT MATTER DISCLOSED HEREIN ARE PROPRIETARY ITEMS TO WHICH TAMURA RETAINS THE EXCLUSIVE RIGHT OF DISSEMINATION, REPRODUCTION, MANUFACTURE AND SALE. THIS DRAWING, PRINT OR DOCUMENT IS SUBMITTED IN CONFIDENCE FOR CONSIDERATION BY THE RECIPIENT ALONE UNLESS PERMISSION FOR FURTHER DISCLOSURE IS EXPRESSLY GRANTED IN WRITING.				