

RUBBER BOX
COLOR: YELLOW

CAUTION LABEL

#12-3 SJTW
300V CORD
COLOR: YELLOW

NEMA 5-15
SUPER-SAFETY
DUAL-SIDED OUTLET BOX
PART #3000-1

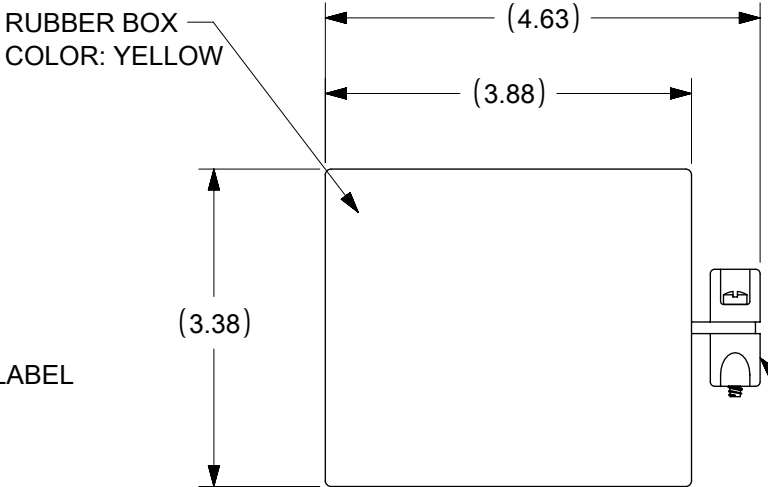

NYLON CORD CLAMP
COLOR: YELLOW

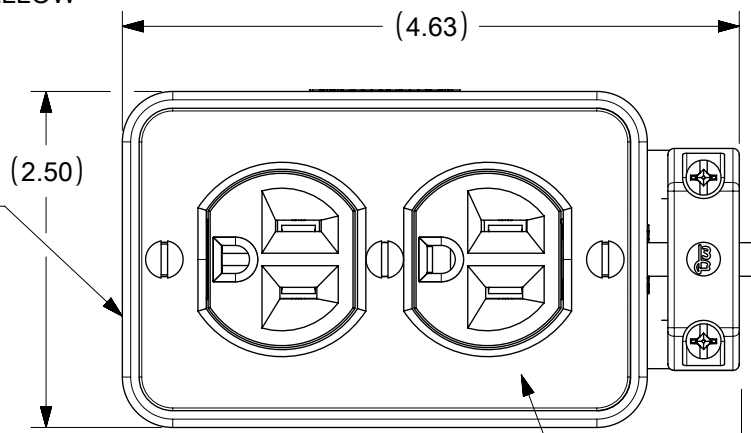

NYLON COVER PLATE
COLOR: YELLOW

NEMA 5-15P
PLUG

(1.72)

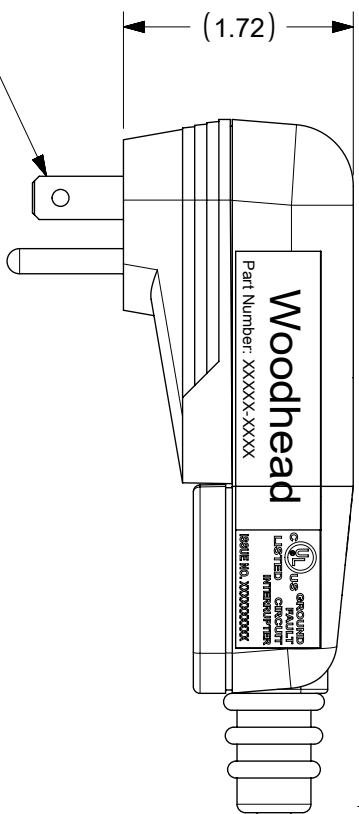

(1.93)

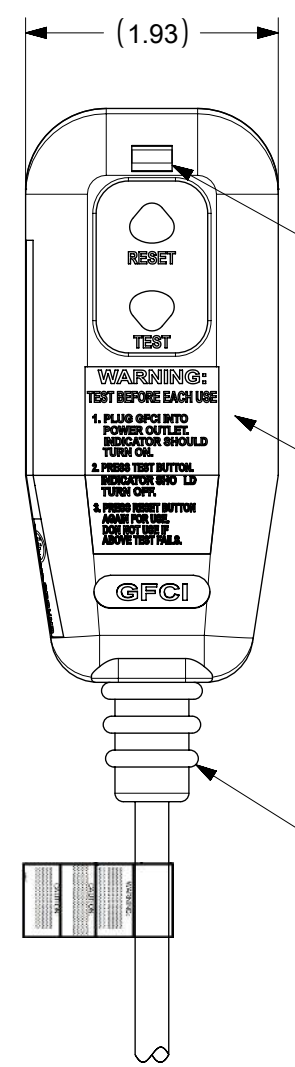

LED INDICATOR
CONFIRMS POWER
AND FAULT STATUS

HIGH STRENGTH
POLYCARBONATE
HOUSING
COLOR: BLACK

CORD STRAIN
RELIEF
COLOR: BLACK

LENGTH "L"

MATERIAL NO.	ENGINEERING NO.	LENGTH "L"	POWER-UP
1301530075	15053-2A	2 FT ± 1 IN	AUTO
1301530073	15053-25A	25 FT ± 2 IN	AUTO
1301530078	15053-50A	50 FT ± 4 IN	AUTO
1301530076	15053-2M	2 FT ± 1 IN	MANUAL
1301530074	15053-25M	25 FT ± 2 IN	MANUAL
1301530079	15053-50M	50 FT ± 4 IN	MANUAL

TECHNICAL:
LISTED: UL AND cUL
RATED SUPPLY VOLTAGE: 120 VAC
RATED CURRENT: UP TO 15 AMPS OR CABLE RATING
RESET TYPE: AUTOMATIC OR MANUAL
OPERATING FREQUENCY: 60 Hz
TYPE: CLASS A
GROUND TRIP CURRENT: 4-6 mA
OVERLOAD CURRENT: 90 AMP 125 VAC
INSULATION VOLTAGE: 1,500 VRMS - 1 MINUTE
ENDURANCE OPERATIONS: 3000 OPERATIONS

FUNCTIONAL SYMBOLS		THIS DRAWING CONTAINS INFORMATION THAT IS PROPRIETARY TO MOLEX ELECTRONIC TECHNOLOGIES, LLC AND SHOULD NOT BE USED WITHOUT WRITTEN PERMISSION		CURRENT REV DESC:	
INCH	NTS	GENERAL TOLERANCES (UNLESS SPECIFIED)		<p>molex</p> <p>120V 15A GFCI PLUG W/ RCPT BOX NEMA 5-15</p> <p>PRODUCT CUSTOMER DRAWING</p> <p>DOCUMENT NUMBER: SD-130153-019 DOC TYPE: PSD DOC PART: 001 REVISION: A1</p>	
4 PLACES	±	ANGULAR TOL ± 0.5°			
3 PLACES	±	DIVISIONAL SYMBOLS			
2 PLACES	± 0.13	INITIAL REVISION:			
1 PLACE	± 0.25	DRAFT WHERE APPLICABLE MUST REMAIN WITHIN DIMENSIONS			
0 PLACES	±	THIRD ANGLE PROJECTION		SERIES: 130153	
MATERIAL NUMBER		CUSTOMER		SHEET NUMBER	
SEE TABLE		GENERAL MARKET		1 OF 1	