

REVISIONS					
P	LTR	DESCRIPTION	DATE	DMN	APVD
AB	ECR-12-021893		29MAR2018	FL	HL

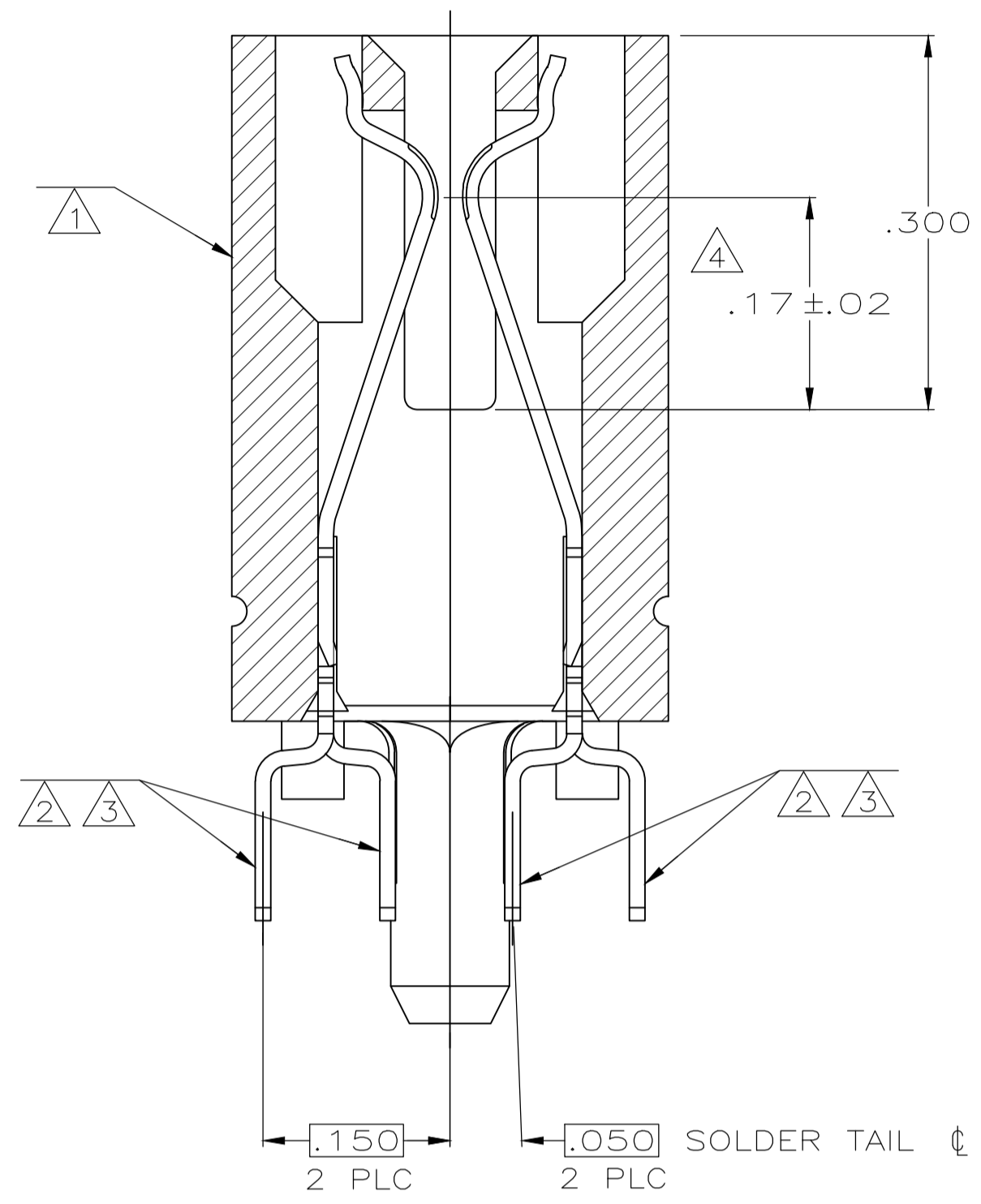

- 1 HOUSING: HIGH TEMPERATURE THERMOPLASTIC. COLOR: BROWN.
- 2 CONTACT: PHOSPHOR BRONZE.
- 3 CONTACT FINISH: .000100 MIN NICKEL ALL OVER, .000030 MIN GOLD OVER NICKEL IN CONTACT AREA, .000100 MIN TIN-LEAD OVER NICKEL ON SOLDER TAILS.
- 4 DISTANCE FROM CONTACT POINT TO BOTTOM OF CARD SLOT.
- 5 AMP PART NUMBER, DATE CODE AND CSA LOGO MARKED IN APPROXIMATE AREA SHOWN.
- 6 PIN ONE IDENTIFIER NOTCH ONLY ON PART NUMBERS INDICATED.
- 7 OBSOLETE PARTS: OBSOLETE CIS STREAMLINING PER D.RENAUD/D.SINISI

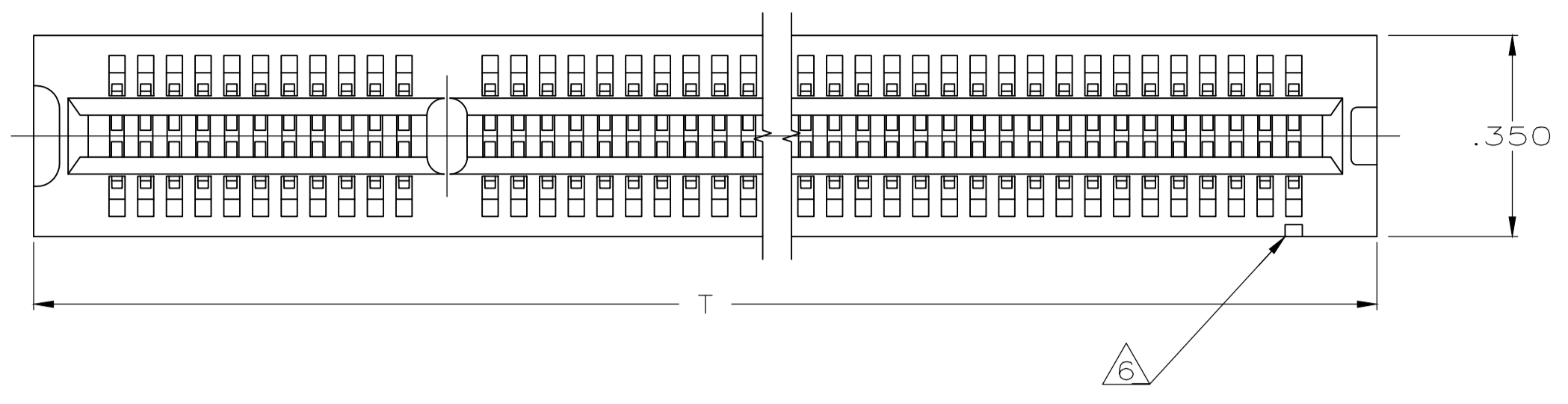
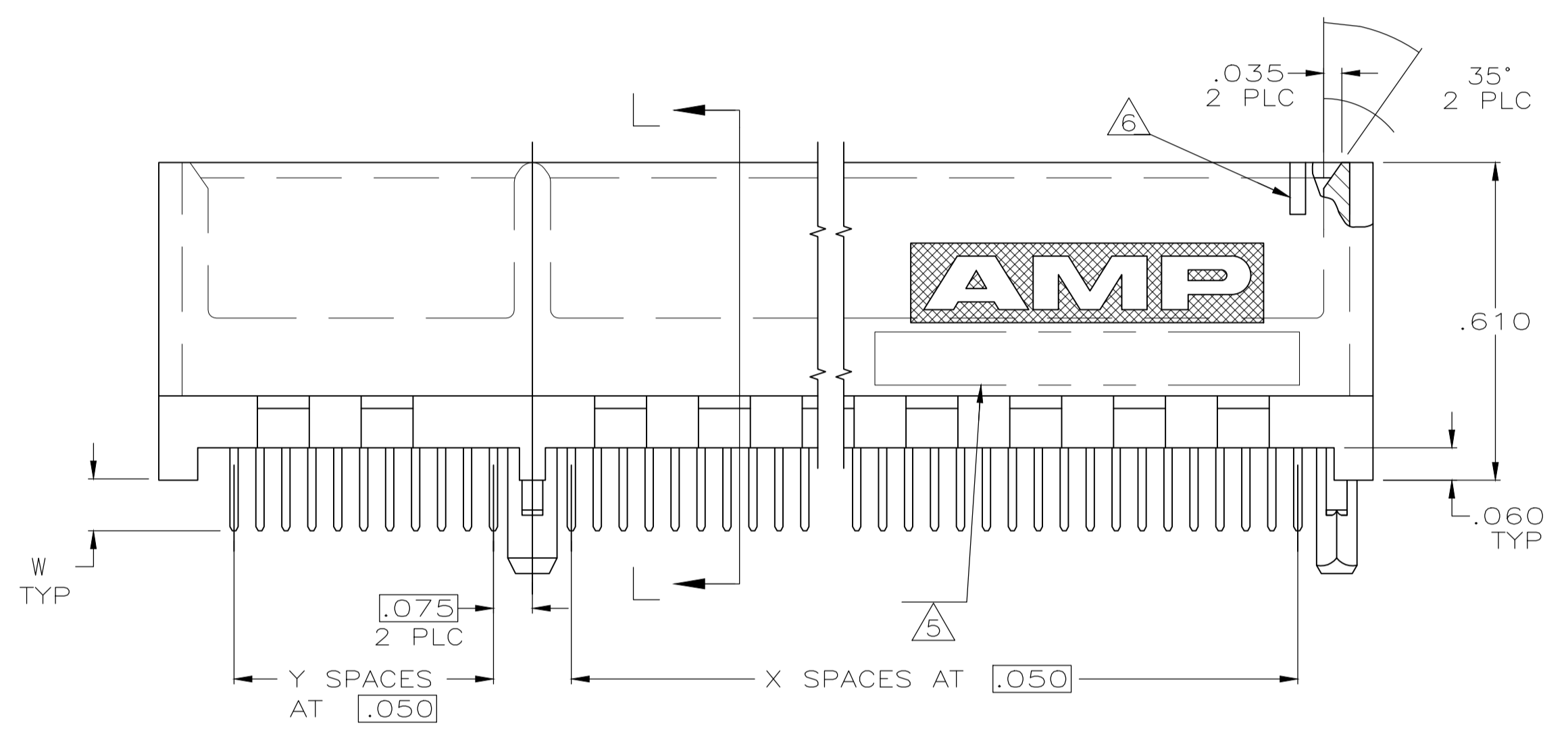

SECTION L-L
SCALE 8:1

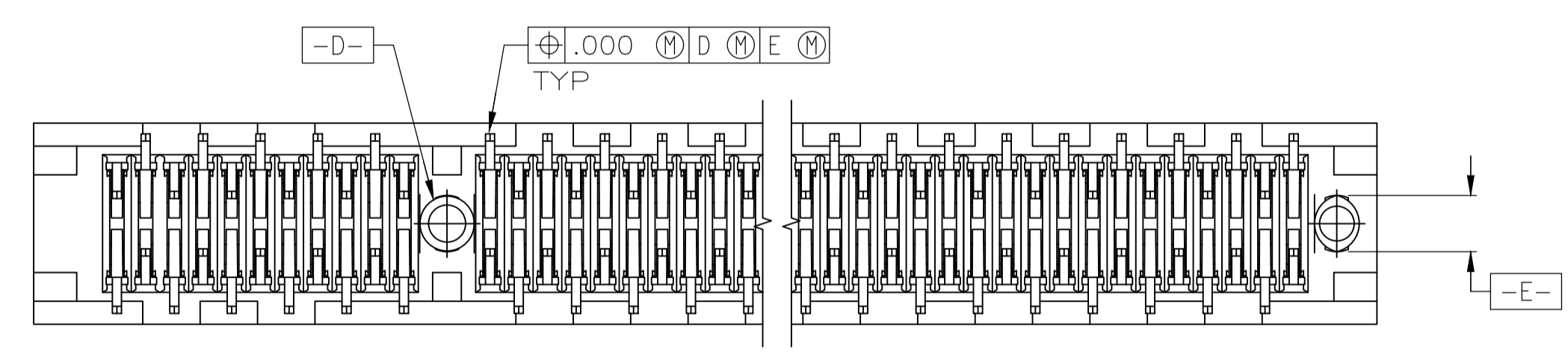

SEE SHEET 2 FOR HOLE PATTERNS

OBSOLETE	.125	NO	B	1.800	1.760	2.59	.610	10	33	45	1-650090-4
OBSOLETE	.140	NO	B	1.800	1.760	2.59	.610	10	33	45	1-650090-3
OBSOLETE	.140	NO	A	1.050	1.010	1.84	.610	10	18	30	1-650090-2
OBSOLETE	.140	NO	C	2.200	2.160	4.34	1.960	37	41	80	1-650090-1
OBSOLETE	.100	NO	B	2.100	2.060	4.59	2.310	44	39	85	1-650090-0
OBSOLETE	.100	NO	C	2.200	2.160	4.34	1.960	37	41	80	650090-9
OBSOLETE	.125	YES	A	2.350	2.310	3.14	.610	10	44	56	650090-8
OBSOLETE	.100	NO	B	.700	.660	1.49	.610	10	11	23	650090-7
OBSOLETE	.100	NO	A	1.050	1.010	1.84	.610	10	18	30	650090-6
OBSOLETE	.100	NO	A	2.550	2.510	3.34	.610	10	48	60	650090-5
OBSOLETE	.100	NO	A	.550	.510	1.34	.610	10	8	20	650090-4
OBSOLETE	.100	NO	A	1.550	1.510	2.34	.610	10	28	40	650090-3
OBSOLETE	.100	NO	B	1.800	1.760	2.59	.610	10	33	45	650090-2
OBSOLETE	.100	YES	A	2.350	2.310	3.14	.610	10	44	56	650090-1

W	PIN ONE IDENTIFIER	HOLE PATTERN	V	U	T	S	Y	X	NO OF DUAL POSN	PART NUMBER

THIS DRAWING IS A CONTROLLED DOCUMENT. DIMENSIONS: INCHES. TOLERANCES UNLESS OTHERWISE SPECIFIED: 0 PLC ± -, 1 PLC ± .01, 2 PLC ± .01, 3 PLC ± .005, 4 PLC ± .005, ANGLES ± .2°.

APPROVED: M. BOWERS. DATE: 7-22-91. NAME: K.L. CLOUSER/UTA. DATE: 3/20/91.

STE TE Connectivity. PRODUCT SPEC: 108-14034. APPLICATION SPEC: 114-26012. SIZE: A1. CAGE CODE: 00779. DRAWING NO: 650090. WEIGHT: 0. RESTRICTED TO: CUSTOMER DRAWING. SCALE: 4:1. SHEET: 1 OF 2. REV: AB.

