

TABLE 1			
AHSP P/N	LENGTH "A"	ACD P/N	DESCRIPTION
NDVVYF-C101	1000±20MM	SF-NDVVYF0001-001M	OSFP 30AWG PASSIVE, 1M
NDVVYF-C102	2000±40MM	TBD	TBD
NDVVYF-C104	1500±20MM	SF-NDVVYF0004-001.5M	OSFP 30AWG PASSIVE, 1.5M

REVISIONS						
ZONE	REV.	ECN	DESCRIPTION	BY	DATE	APPROVED
ALL	A	MKHN-18121403	NEW RELEASE	HCL-PB	12/26/2018	M.HUSSAIN
	B	RGAO-20121603	ADDED ACD P/N COLUMN TO TABLE 1. ADDED CE STAMP TO SHEET 1. ADDED REFERENCE DIMENSION TO BENDING RADIUS.	N.ZENG	12/16/2020	Y.CHEN
	C	RGAO-21020301	ADDED DESCRIPTION COLUMN TO TABLE 1.	N.ZENG	2/4/2021	Y.CHEN

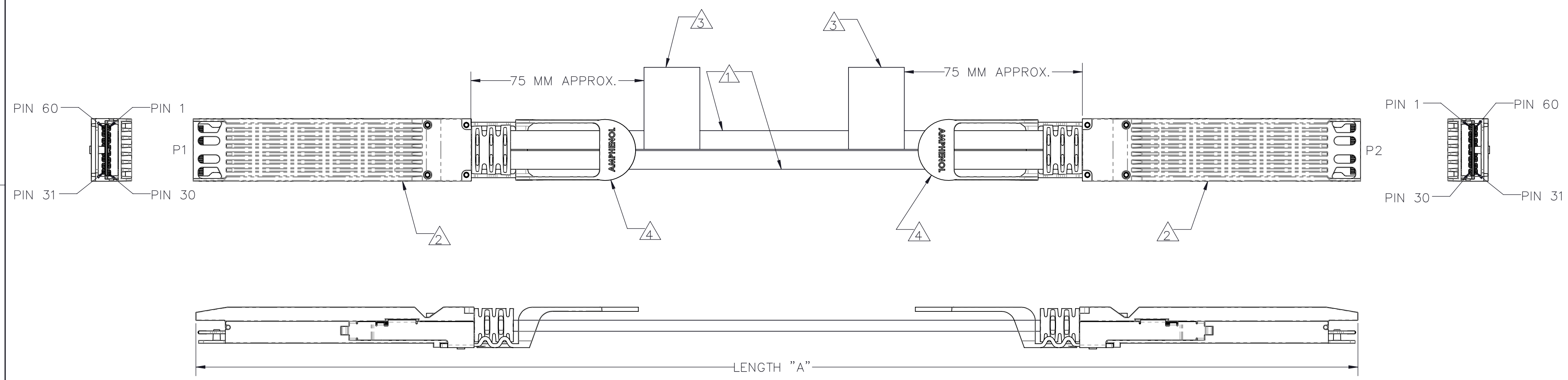
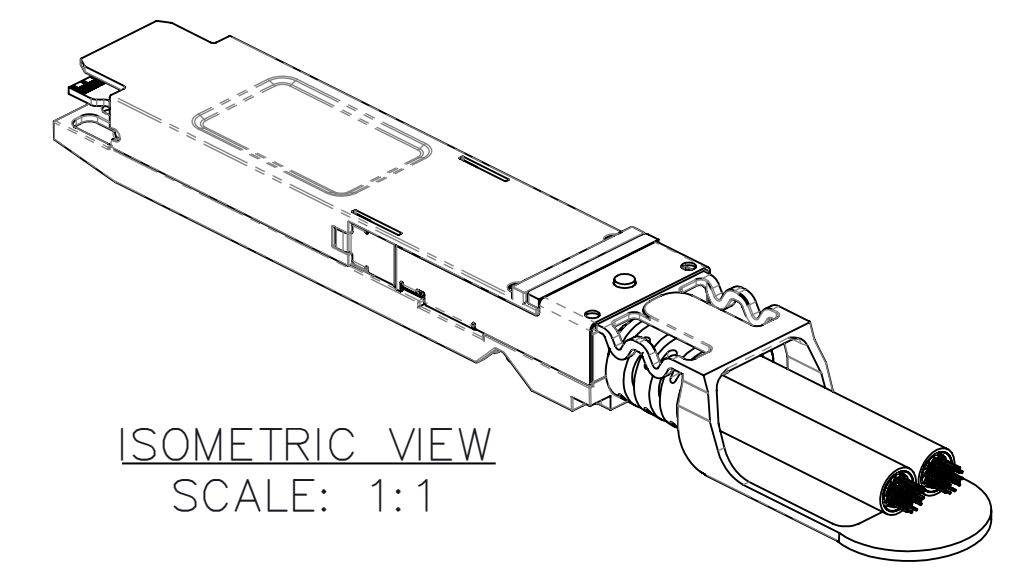
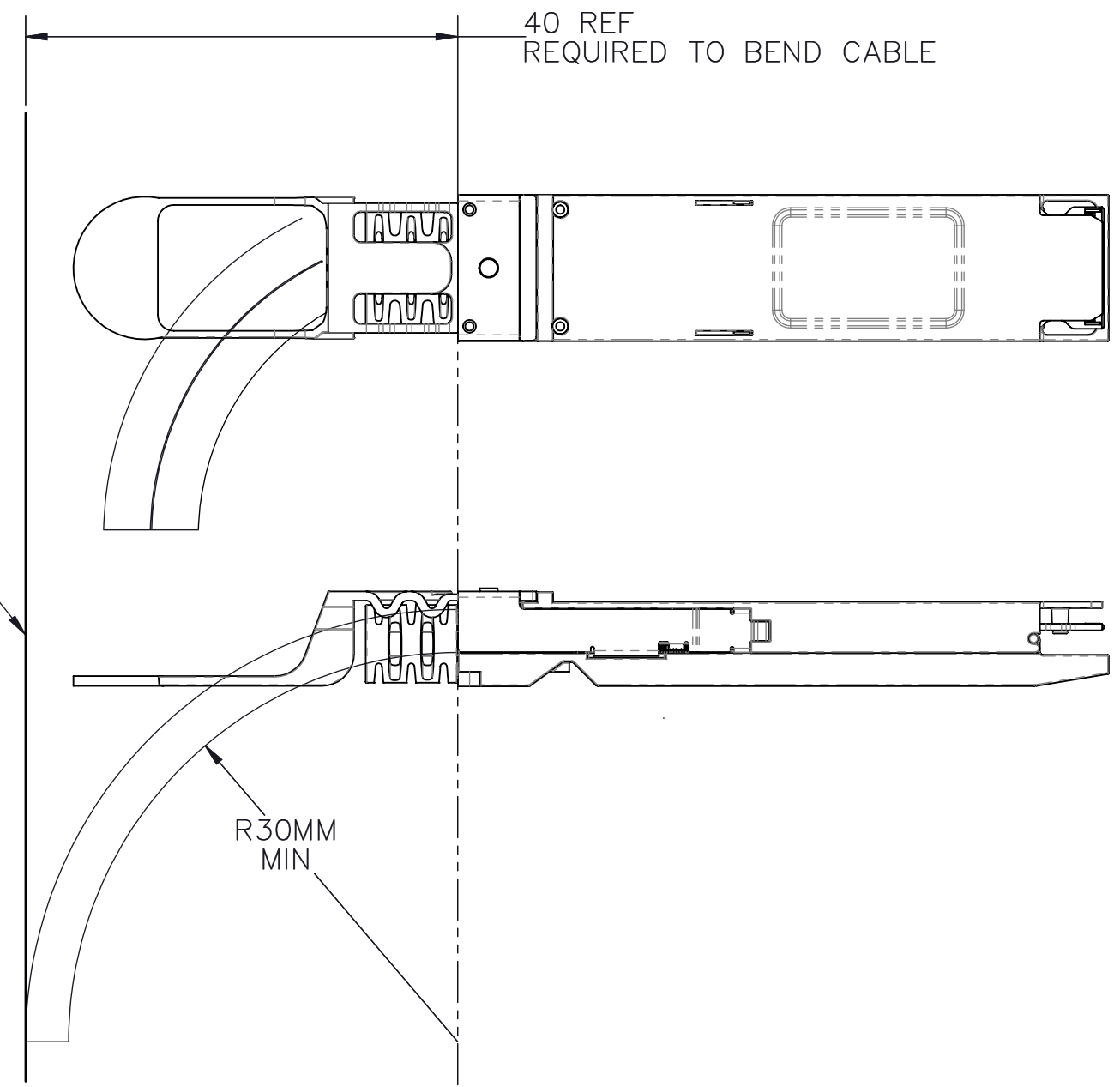
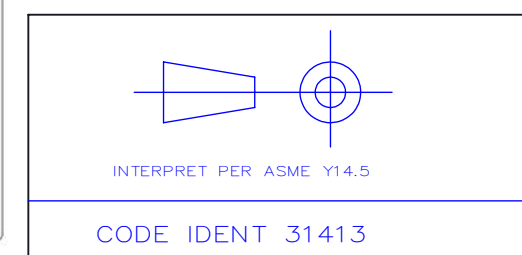
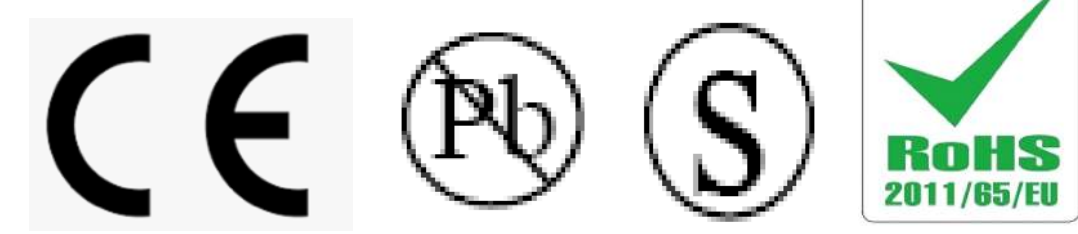

TABLE 2	
ITEM No.	DESCRIPTION
1	30 AWG, 8-PR, PVC JKT, AWM STYLE 20276 80°C, VM1
2	PLUG, OSFP, REFERENCE "OSFP MSA"
3	LABEL, FLAGGED-AHSP PN, SN, LENGTH
4	PULL TAB, BLUE 2718
5	EPROM - REFERENCE OSFP MSA & SFF-8636, PAGE A0 ONLY



- NOTES:
- THIS DRAWING IS RESERVED FOR AMPHENOL CABLES ON DEMAND.
 - ASSEMBLIES SHALL BE COMPLIANT TO OSFP MSA SPECIFICATION.
 - CABLE ASSEMBLIES, COMPONENTS AND SUB-COMPONENTS SHALL BE COMPLIANT TO EU DIRECTIVE 2011/65/EU-RoHS2.
 - CABLE ASSEMBLIES MUST MEET SHIELDING EFFECTIVENESS REQUIREMENTS OF 35DB MINIMUM FROM 1-10GHZ AND 30DB FROM 10-18 GHZ.
 - EPROM CONTENT SHALL BE COMPLIANT WITH OSFP MSA & SFF-8636 SPECIFICATIONS FOR 100GBASE-CR-4. EPROM REVISION IS EQUAL TO CUSTOMER PART NUMBER REVISION UNLESS OTHERWISE NOTED.
 - PACKAGE COMPLETED ASSY IN AN APPROPRIATELY SIZED ESD BAG.
 - UL LABEL MUST BE ON SHIPPING CARTON PER SUBJECT 764 OF THE UL COMPONENT WIRING HARNESS (ZPFW2) FILE #E86140. CSA LABEL MUST BE ON SHIPPING CARTON.



TOLERANCES	DWN 12/14/2018	Amphenol AHSP A Division of Amphenol Corporation 200 Innovative Way, Suite 201, Nashua, N.H. 03062 (603) 879-3000	TITLE
0.0 ± 0.1	M.HUSSAIN 12/14/2018		CABLE ASSY, OSFP PASSIVE, 100Ω, 30 AWG
0.00 ± 0.08	M.HUSSAIN 12/14/2018		PART NO.
0.000 ± -	APVD 12/14/2018		SEE TABLE 1
ANGLES ± 1.0°	M.HUSSAIN 12/14/2018		C-NDVVYF-C199
UNLESS OTHERWISE SPECIFIED DIMENSIONS ARE IN MM		REV	N/A
CUSTOMER USE DRAWING		REV	C
SIZE D	SCALE 2:1	SHEET 1 OF 2	

REVISIONS						
ZONE	REV.	ECN	DESCRIPTION	BY	DATE	APPROVED
			SEE SHEET 1			

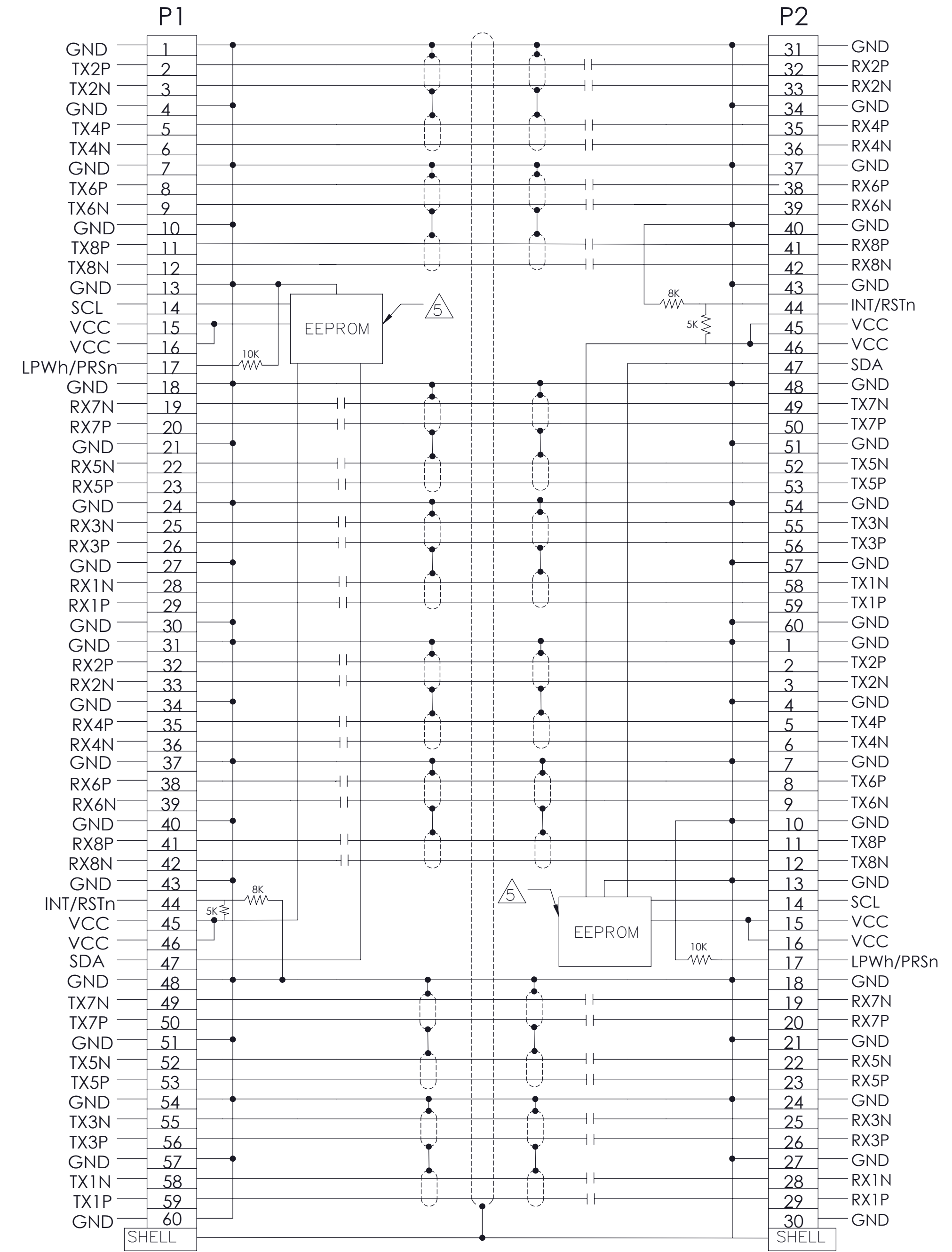

NOTE: DC BLOCKING CAP VALUE IS 100nF

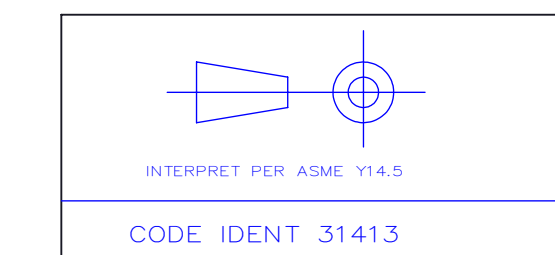

CODE IDENT 31413

TOLERANCES		DWN 12/14/2018	Amphenol AHSP A Division of Amphenol Corporation 200 Innovative Way, Suite 201, Nashua, N.H. 03062 (603) 879-3000
0.0	± 0.1	M.HUSSAIN	
0.00	± 0.08	M.HUSSAIN	
0.000	± -	APVD 12/14/2018	
ANGLES	± 1.0°	M.HUSSAIN	
UNLESS OTHERWISE SPECIFIED DIMENSIONS ARE IN MM			TITLE
CUSTOMER USE DRAWING			CABLE ASSY, OSFP PASSIVE, 100Ω, 30 AWG
PART NO.		SEE TABLE 1	REV N/A
DRAWING NO.		C-NDVVYF-C199	REV C
SIZE D	SCALE 1:1	SHEET 2 of 2	