

PM Motor
PG Type

Applications

Home electric appliances : Air-conditioners
OA Equipment : Printers / Photocopiers
Power Tools : Drills / Drivers

Reference Characteristics

Motor Size	PG20L-020		
Reduction Ratio	1/34.3	1/91	1/185.4
Drive Characteristics	BIPOLAR CONST. VOLT.		
Drive Voltage	12[V]		
Drive Method	2-2 PHASE		
Step Angle (2phase drive)	0.524°	0.197°	0.097°
DC Resistance	80[Ω]		
Insulation Resistance	100M[Ω] MIN		
Dielectric Strength	AC 500[V] 1[min]		
Class of Insulation	CLASS B		
Operating Temp.	-10[°C] ~ 50[°C]		
Storage Temp.	-30[°C] ~ 80[°C]		
Operating Hum.	20[%] RH ~ 90[%] RH		

Torque Characteristics

PG20L-020 Reduction Ratio 1/91

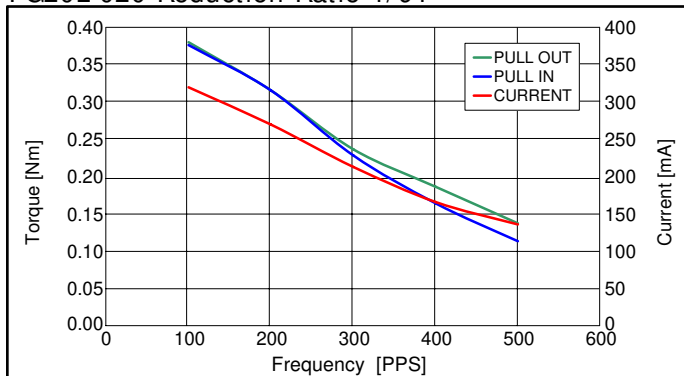

PG20L-020 Reduction Ratio 1/34.3

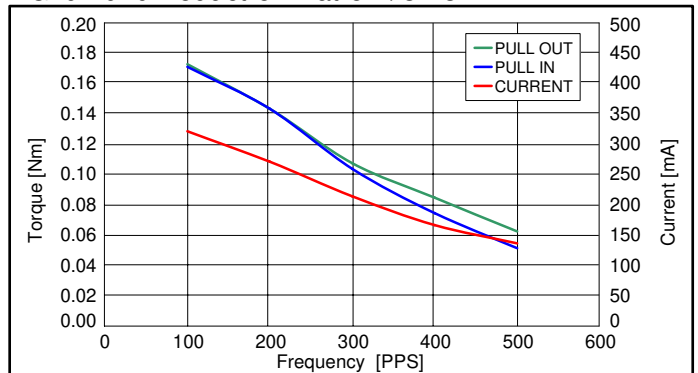

PG20L-020 Reduction Ratio 1/185.4

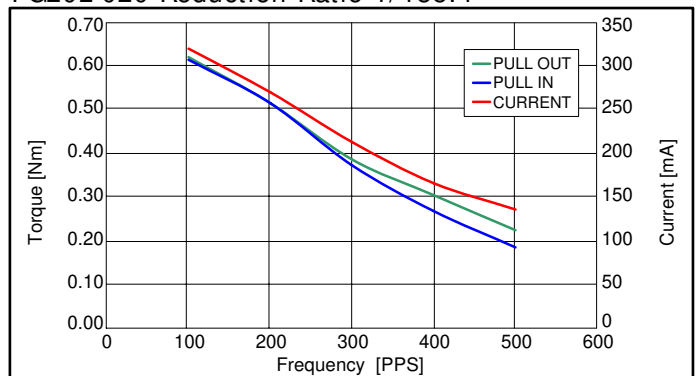

These torque values are reference only. Heat radiation conditions and temperature rise effect by duty are different on each equipment, therefore please select motors after considering the heat conditions in the actual equipment.

Dimensions

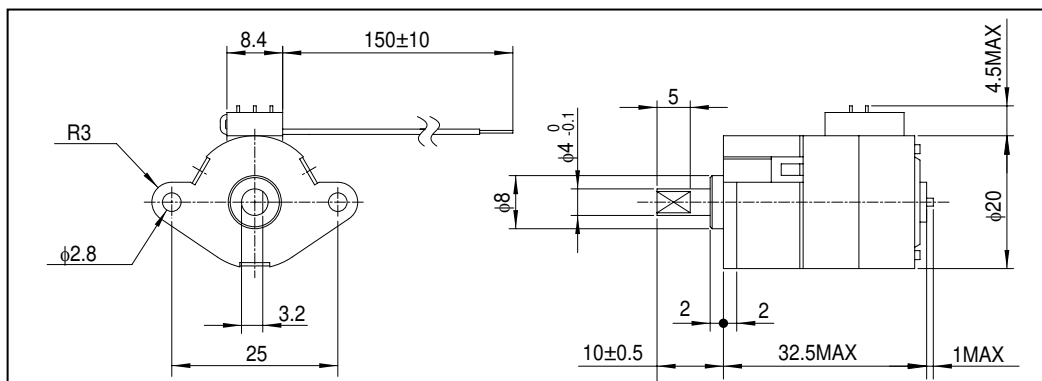

The dimensions shown are for reference purpose and can be modified to your requirements.
Contact our Engineering Department for details.