

TOOL			CONTACT	
PART NUMBER	INSERTION TIP COLOR	EXTRACT TIP COLOR	SIZE	TYPE
1643914-1	N/A	Red	8	Drawer Series, Domino Series
1643915-1	Yellow	White	12	Drawer Series, Domino Series, FORGE
1643916-1	Blue	White	16	Drawer Series, Domino Series
1643917-1	Red	White	20	Drawer Series, Domino Series
1643921-1	N/A	Light Yellow	0	Drawer Series, Domino Series, FORGE
1643922-1	N/A	Blue	4	Drawer Series, Domino Series, FORGE

Figure 1

## 1. INTRODUCTION

These insertion/extraction tools are designed to insert and remove crimp type and threaded circular contacts from connectors. Each tool tip is color coded to indicate the purpose (insertion or extraction) and the size of the contact. See Figure 1.

Reasons for re-issue of this instruction sheet are provided in Section 4, REVISION SUMMARY.

## 2. USING THE TOOL (Refer to Figure 2)



### **DANGER**

To prevent possibility of injury, always hold the tool handle when inserting or removing contacts. Do not hold tool with tip against the palm of your hand.

### 2.1. Insertion

1. Slide the contact wire barrel into the end of the tool tip until the tip butts against the shoulder of the contact.
2. Place the wire over the slot in the tool tip. Apply light pressure on the wire until the tip spreads and allows the wire to enter the tip.
3. Align the contact and tool tip with the desired connector contact cavity.
4. Hold the wire against the serrations in the tool handle, and push the tool straight into the contact cavity until the contact bottoms.
5. Remove the tool from the contact. Pull back lightly on the wire to ensure that the contact is secure in the cavity.

### 2.2. Extraction

1. Align the tool tip with the desired connector contact cavity.
2. Gently push the tool tip straight into the contact cavity and over the contact wire barrel until it butts against the shoulder of the contact.

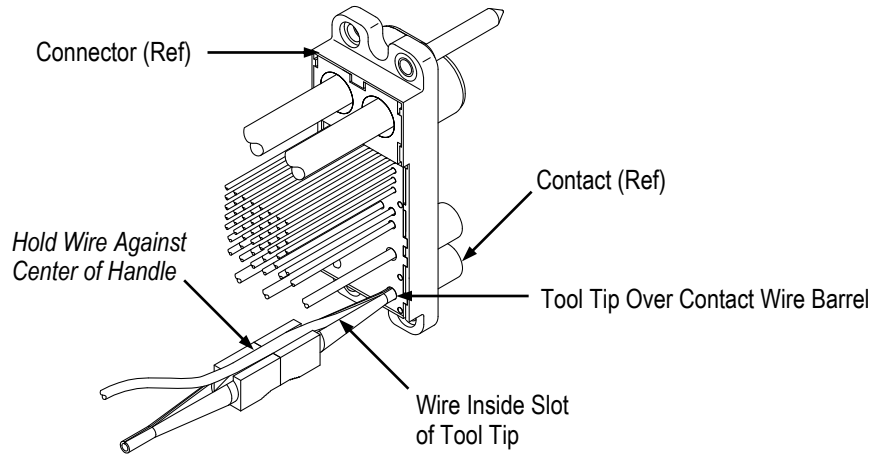

Figure 2

3. Place the wire over the slot in the tool tip. Apply light pressure on the wire until the tool tip spreads and allows the wire to enter the tip.
4. Hold the wire against the center of the tool handle (some have serrations), and gently pull back.

**CAUTION**

*Do not use excessive force when removing contacts. If you experience difficulty in removing the contact, re-insert the tool tip, making sure that the tip is properly positioned in the cavity, and try again.*

### 3. TOOL MAINTENANCE

It is recommended that the tool be inspected when you receive it and at regularly scheduled intervals. The tool is not repairable and should be replaced when it is worn or damaged. Store the tool in a clean, dry place and clean the tool with a soft, lint-free cloth. Additional tools can be purchased from:

CUSTOMER SERVICE (38-35)  
TYCO ELECTRONICS CORPORATION  
PO BOX 3608  
HARRISBURG PA 17105-3608

### 4. REVISION SUMMARY

Revisions to this instruction sheet include:

- Added FORGE contacts