

DS26334DK/DS26324DK 3.3V, 16-Channel, E1/T1/J1 Short-/Long-Haul LIU Design Kit

www.maxim-ic.com

GENERAL DESCRIPTION

The DS26334DK/DS26324DK is a fully integrated design kit for the DS26334 and DS26324 3.3V, 16-channel, E1/T1/J1 line interface units (LIUs). This design kit contains all the necessary circuitry to evaluate the DS26334 and DS26324 in all modes of operation. The design kit also includes an on-board microprocessor to run real-time code for further part evaluation.

DESIGN KIT CONTENTS

DS26334DK Board with a DS26324 or DS26334
5V AC/DC Adapter
3ft USB Cable
Download:
ChipView Software
DS26334DK/DS26324DK.def Definition File
DS26334DK/DS26324DK Data Sheet

ORDERING INFORMATION

PART	DESCRIPTION
DS26334DK	Design Kit Board for DS26334
DS26324DK	Design Kit Board for DS26324

FEATURES

- **Expedites New Designs by Eliminating First-Pass Prototyping**
- **Demonstrates Key Functions of the DS26334/DS26324**
- **Includes DS26334/DS26324 x 16-Port LIU, Transformers, 75Ω BNC Connectors, RJ-48 Connectors, and Termination Passives**
- **Communicates Directly with any PC with a USB or RS-232 Serial Interface**
- **High-Level Windows®-Based Software Provides Visual Access to All Registers**
- **Software-Controlled (Register) Mapped Configuration Switches Facilitate Real-Time Clock and Signal Routing**
- **Precision Test Points for All Clocks and Signals**
- **On-Board T1 and E1 Crystal Oscillators for Stable Clock Generation**
- **On-Board BERT for Testing and Pattern Generation**

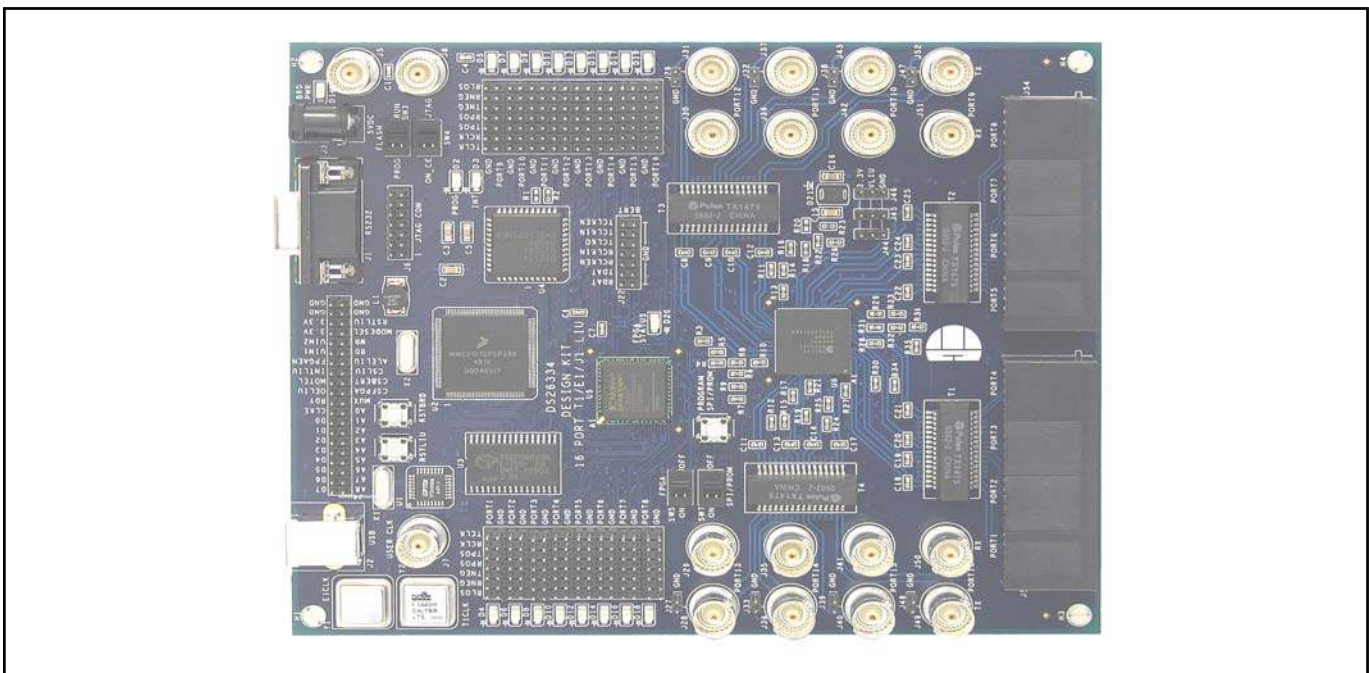

Windows is a registered trademark of Microsoft Corp.

TABLE OF CONTENTS

COMPONENT LIST	3
BOARD FLOORPLAN.....	6
BASIC OPERATION.....	7
HARDWARE CONFIGURATION	7
QUICK START (HARDWARE SETTINGS—SINGLE POWER SUPPLY).....	7
JTAG CONFIGURATION	7
<i>Table 1. JTAG Connector (J6) Pinout.....</i>	<i>7</i>
<i>Figure 1. DS26334DK JTAG Chain.....</i>	<i>8</i>
ADDRESS/DATA BUS CONNECTOR.....	8
<i>Table 2. Address/Data Connector Pinout.....</i>	<i>8</i>
TELECOM CLOCK AND DATA TEST POINTS	9
<i>Table 3. Telecom Connector Pinout.....</i>	<i>9</i>
ON-BOARD BIT ERROR-RATE TESTER (BERT)	9
<i>Table 4. BERT Connector Pinout</i>	<i>9</i>
PROM SPI CONFIGURATION.....	10
<i>Figure 2. SPI Timing Diagram</i>	<i>10</i>
<i>Figure 3. SPI Configuration with PROM</i>	<i>11</i>
<i>Table 5. Configuration Memory</i>	<i>11</i>
SOFTWARE CONFIGURATION	12
QUICK START (SOFTWARE—CHIPVIEW)	12
MEMORY MAP	12
<i>Table 6. DS26334DK Relative Address Map.....</i>	<i>12</i>
<i>Table 7. General-Purpose FPGA Memory Map.....</i>	<i>12</i>
ID REGISTERS.....	13
CONTROL REGISTERS.....	13
DS26334 INFORMATION.....	21
DS26324 INFORMATION.....	21
DS26334DK/DS26324DK INFORMATION.....	21
TECHNICAL SUPPORT	21
ERRATA	21
SCHEMATICS	21

COMPONENT LIST

DESIGNATION	QTY	DESCRIPTION	SUPPLIER/ PART NUMBER
C1, C4, C6, C7, C31, C33–C41, C43–C46, C49, C51–C54, C56– C58, C61–C93, C95–C108	66	0.1 μ F \pm 20%, 16V X7R ceramic capacitors (0603)	AVX 0603YC104MAT
C2, C3, C27, C37, C42, C48, C50, C55, C59, C60	10	1 μ F \pm 10%, 16V ceramic capacitors (1206)	Panasonic ECJ-3YB1C105K
C5, C16, C26, C30, C34, C35, C94	7	10 μ F \pm 20%, 10V ceramic capacitors (1206)	Panasonic ECJ-3YB1A106M
C8–C14, C17–C25	16	470pF \pm 10%, 100V ceramic capacitors (0603)	Panasonic ECJ-1VB2A471K
C15	1	6.8 μ F \pm 10%, 6.3V X5R ceramic capacitors (1206)	Panasonic ECJ-3YB0J685K
C28, C29, C32, C109, C110	5	68 μ F \pm 20%, 16V tantalum capacitors (D case)	Panasonic ECS-T1CD686R
C36, C38, C47	3	22pF \pm 5%, 25V ceramic capacitors (0603)	AVX 06033A220JAT
C39, C40	2	10pF \pm 5%, 50V ceramic capacitors (1206) (tall case)	Phycomp 1206CG100J9B200
D1, D20	2	Green LEDs (SMD)	Panasonic LN1351C
D2–D19	18	Red LEDs (SMD)	Panasonic LN1251C
D21, D22, D23	3	1A, 40V Schottky diodes	International Rectifier 10BQ040
H1–H4	4	KIT, 4-40 hardware 0.75 nylon standoff and 0.25 nylon screw	Not applicable 4-40KIT2
J1	1	DB9 right-angle connector (short case)	AMP 788750-2
J2	1	Black, single right angle (Type B)	Molex Not applicable
J3	1	2.5mm connector Power jack, right-angle PC board mount	Switchcraft RAPC712
J4	1	40-pin terminal strip (dual row, vertical)	Samtec TSW-120-07-T-D
J5, J7, J8, J28–J31, J34–J37, J40–J43, J49–J52	19	5-pin, 75 Ω BNC connectors (vertical)	Cambridge CP-BNCP-004
J6, J9–J25	18	14-pin headers (dual row, vertical)	Samtec TSW-107-14-T-D
J26, J27, J32, J33, J38, J39, J47, J48	8	2-pin headers, 0.100in centers (vertical)	Samtec TSW-102-07-T-S
J44, J45, J46	3	100-mil 3-position jumpers	Samtec Not applicable
J53, J54	2	8-pin 4-port RJ45 jacks (right angle)	Molex 43223-8140
L1	1	1.0 μ H \pm 20%, 2-pin SMT inductor	Coiltronics UP1B-1R0
R1, R20, R61, R90, R138	5	Resistors (0603) DO NOT POPULATE	—

DESIGNATION	QTY	DESCRIPTION	SUPPLIER/ PART NUMBER
R2, R23, R37, R38, R39, R42, R45, R47–R50, R52, R53, R55, R57– R60, R66–R69, R71, R72, R74– R76, R79, R80, R85, R88, R89, R91, R99, R103, R104, R105, R110	38	10k Ω \pm 5%, 1/16W resistors (0603)	Panasonic ERJ-3GEYJ103V
R3–R19, R21, R22, R24–R36, R41, R44, R46, R51, R63, R64, R65, R81, R82, R102, R109, R116, R120, R121, R122, R126, R130, R131, R132, R134–R137, R139, R140, R148, R151, R153	60	33 Ω \pm 5%, 1/16W resistors (0603)	Panasonic ERJ-3GEYJ330V
R40, R70, R73, R77, R78, R83, R84, R86, R87, R92, R93, R95– R98, R100, R101, R106, R107, R108	20	330 Ω \pm 5%, 1/16W resistors (0603)	Panasonic ERJ-3GEYJ331V
R43, R62	2	15k Ω \pm 5%, 1/16W resistors (0603)	Panasonic ERJ-3GEYJ153V
R54	1	Resistor (1206) DO NOT POPULATE	—
R56	1	470 Ω \pm 5%, 1/16W resistor (0603)	Panasonic ERJ-3GEYJ471V
R94	1	51 Ω \pm 5%, 1/16W resistor (0603)	Panasonic ERJ-3GEYJ510V
R111–R115, R117, R118, R119, R123, R124, R125, R127, R128, R129, R133, R141–R144, R146, R147, R149, R150, R152, R154–R161	32	60.4 Ω \pm 1%, 1/16W resistors (0603)	Panasonic ERJ-3EKF60R4V
R145	1	22k Ω \pm 5%, 1/16W resistor (0603)	Panasonic ERJ-3GEYJ223V
SW1, SW2, SW6	3	4-pin single-pole switch	Panasonic EVQPAE04M
SW3, SW4, SW5, SW7	4	6-pin slide switches (DPDT, through hole)	Tyco Electronics SSA22
T1–T4	4	32-pin transmit/receive SMT transformers (1:2 and 1:1)	Pulse Engineering TX1475
U1	1	8-bit FIFO USB UART (32-pin LQFP)	FTDI FT245BM
U2	1	MCORE Microcontroller (144-pin LQFP)	Motorola MMC2107PV
U3, U10	2	128k x 8 SRAM (32-pin SO)	Cypress CY62128VL-70SC

DESIGNATION	QTY	DESCRIPTION	SUPPLIER/ PART NUMBER
U4	1	DS2174 EBERT (44-pin PLCC, 0°C to +70°C)	Dallas Semiconductor DS2174Q
U5	1	Spartan-II 2.5V FPGA, 200k gate (256-pin BGA)	Xilinx XC2S200-5FG256C
U6	1	3.3V, 16-channel, E1/T1/J1 long-haul LIU (256-pin BGA, 0°C to +70°C)	Dallas Semiconductor DS26334
U7	1	Dual RS-232 transmitter/receiver (150-mil, 16-pin SO)	Dallas Semiconductor DS232AR
U8, U11	2	High-speed buffers	Fairchild Semiconductor NC7SZ86
U9, U20	2	1.5W, 3.3V or adj, 1A linear regulators (16-pin TSSOP-EP)	Maxim MAX1793EUE-33
U12	1	PROM for FPGA (44-pin TQFP)	Xilinx XC18V02VQ44C
U13, U14, U18	3	Hex inverters (14-pin SO)	Toshiba TC74HC04AFN
U15	1	2.5V or adj linear regulator (8-pin μ MAX/SO)	Maxim MAX1792EUA25
U16	1	Platform flash in-system programmable configuration PROM (2Mb, 20-pin TSSOP)	Xilinx XCF02SVO20C
U17	1	Quad 2-input NAND gate (14-pin SO)	Toshiba TC74HC00AFN
U19	1	Switch debouncer (4-pin SOT143)	Maxim MAX6816EUS-T
X1	1	6.00MHz low-profile crystal	Pletronics LP49-26-6.00M
X2	1	8.000MHz low-profile crystal	Ecliptek Corp. EC1-8.000M
Y1	1	Oscillator, crystal clock 5V, 2.048MHz	SaRonix NTH039A-2.0480
Y2	1	Oscillator, crystal clock 5V, 1.544MHz	SaRonix NTH039A-1.5440

BOARD FLOORPLAN

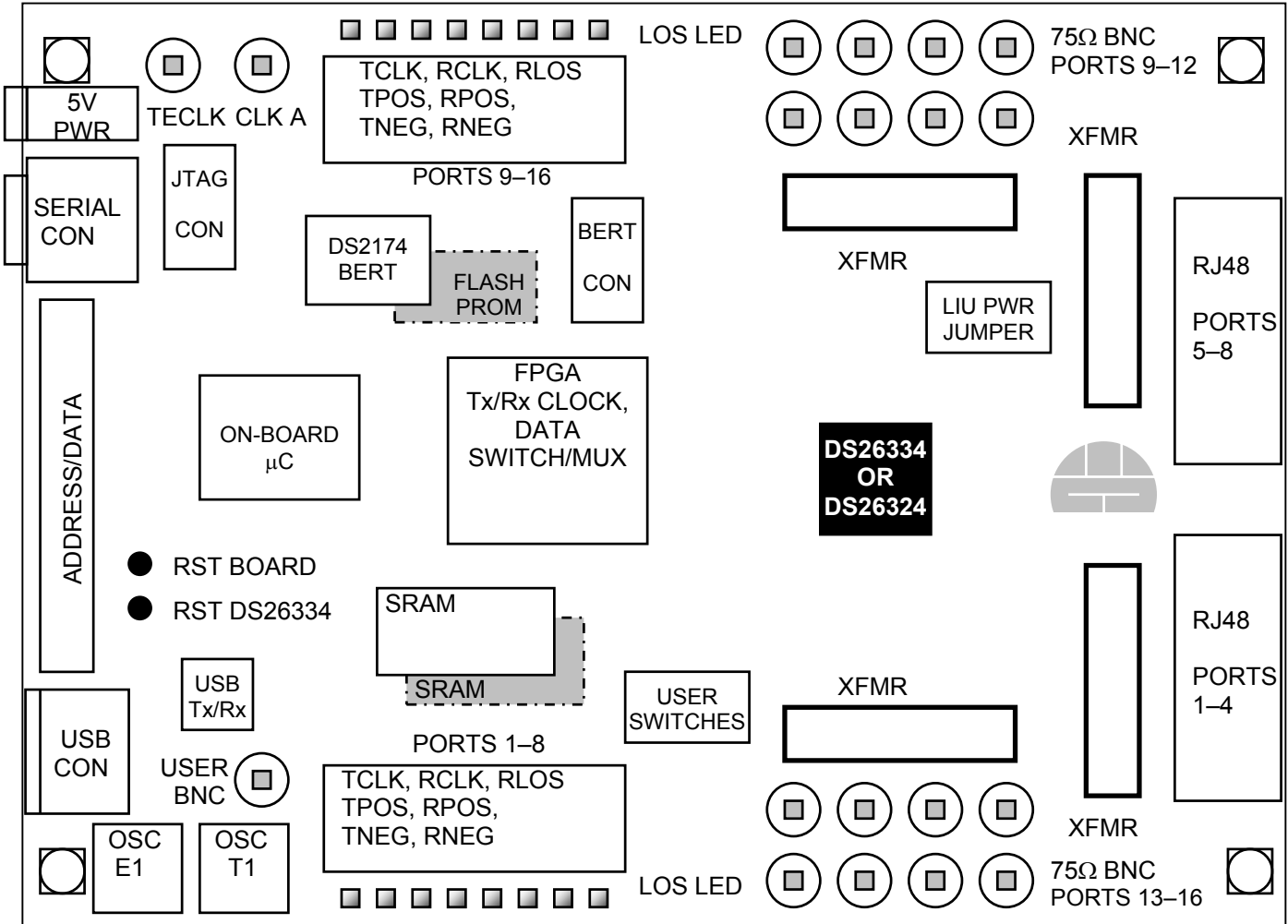

BASIC OPERATION

This design kit relies upon several supporting files, which are available for downloading on our website at www.maxim-ic.com/DS26334DK.

The support files are used with an evaluation program called ChipView, which is available for download at www.maxim-ic.com/telecom.

HARDWARE CONFIGURATION

Quick Start (Hardware Settings—Single Power Supply)

- For single power-supply operation, short jumpers J44, J45, and J46 between the 3.3V pin and the VLIU pin. This connects VDD of the DS26334/DS26324 to the 3.3V supply on the design kit.
- Ensure that the FLASH switch (SW3) is in the *RUN* position.
- Ensure that the FPGA switch (SW5) is in the *ON* position.
- Ensure that the SPI/PROM switch (SW7) is in the *OFF* position.
- If using the serial port, connect an RS-232 serial cable from DS26334DK (J1) to the PC.
- If using the USB port, connect a USB cable from DS26334DK (J2) to the PC.
- Connect AC/DC adapter with an AC power source and the DS26334DK (J3). PWR LED should be on.

JTAG Configuration

The JTAG chain is controlled by the connector JTAG CON (J6) and two on-board switches: FLASH (SW3) and ONCE/JTAG (SW4). Depending on the function, such as programming the internal microcontroller flash or performing boundary scan operations, the JTAG CON connector can be used and the switches can be configured to accomplish the desired task. For information on programming the internal flash of the on-board microcontroller, refer to the MMC2107 microcontroller user manual and board schematic.

For most purposes, having the complete JTAG chain is sufficient. [Figure 1](#) shows the complete chain as well as what order the devices appear during boundary scan. [Table 1](#) shows the pinout of the JTAG connector. Connect any JTAG cable to the connector to perform all operations. Note the JTAG chain changes depending on the switch SW4. The ONCE location of SW4 is used for programming the on-board microcontroller only.

Table 1. JTAG Connector (J6) Pinout

PIN	NAME
1	JTDI
2, 4, 6, 7	GND
3	JTDO
5	JTCLK
8	ALIGN KEY
9	BRD RST
10	JTMS
11	BRD V3.3
12	JDE
13	N.C.
14	JTRST

Figure 1. DS26334DK JTAG Chain

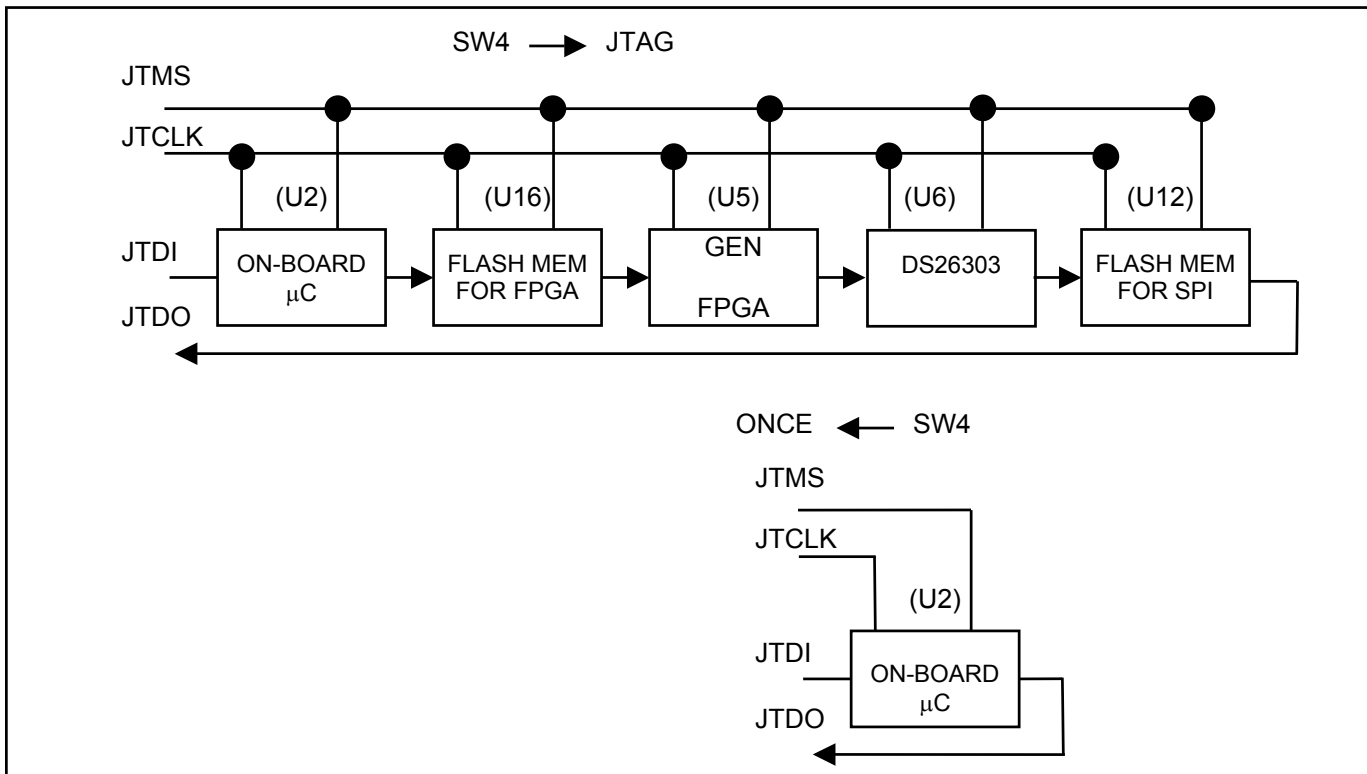

Address/Data Bus Connector

The DS26334DK has a connector (J4) to monitor all local bus activity for the design kit. All the signals can be captured with a high-impedance probe and displayed on an oscilloscope or logic analyzer. **Note:** If the FPGA switch (SW5) is in the “OFF” position, the on-board microcontroller will no longer drive any data onto the local bus. Therefore, the user can now connect the local bus of the DS26334/DS26324 into another system without making any modifications to the hardware. See [Table 2](#) for specific pin information for connector J4.

Table 2. Address/Data Connector Pinout

PIN	NAME	FUNCTION	PIN	NAME	FUNCTION
1	A8	Local Address Bit 8	2	D0	Local Data Bit 0
3	A7	Local Address Bit 7	4	D1	Local Data Bit 1
5	A6	Local Address Bit 6	6	D2	Local Data Bit 2
7	A5	Local Address Bit 5	8	D3	Local Data Bit 3
9	A4	Local Address Bit 4	10	D4	Local Data Bit 4
11	A3	Local Address Bit 3	12	D5	Local Data Bit 5
13	A2	Local Address Bit 2	14	D6	Local Data Bit 6
15	A1	Local Address Bit 1	16	D7	Local Data Bit 7
17	A0	Local Address Bit 0	18	CLKE	SPI Clock Edge Select
19	MUX	Mux	20	RDY	Ready Handshake from LIU
21	CSFPGA	Chip Select FPGA	22	OE	Output Enable LIU
23	CSBERT	Chip Select DS2174	24	MOTEL	Motorola/Intel Select
25	CSLIU	Chip Select DS26334/DS26324	26	INT	Interrupt for DS26334/DS26324
27	ALELIU	Address Latch Enable	28	FPGAEN	FPGA Enable Pin
29	RD	Read Signal	30	UIN1	User Input 1
31	WR	Write Signal	32	UIN2	User Input 2
33	MODESEL	Mode Select	34, 36	3.3V	Board 3.3V
35	RSTLIU	Reset DS26334/DS26324	37–40	GND	Ground

Telecom Clock and Data Test Points

The DS26334DK has high-impedance test points for all the telecom signals that are related to the LIU. These signals are split up by port number and marked with easy to read silkscreen labels. [Table 3](#) shows the telecom connector for port 1. The pinout for this connector is repeated for all 16 ports.

Table 3. Telecom Connector Pinout

PIN	NAME	FUNCTION
1	TCLK	Transmit Clock Input
2, 4, 6, 8, 10, 12, 14	GND	Ground
3	RCLK	Receive Clock Output
5	TPOS	Transmit Positive Data Input
7	RPOS	Receive Positive Data Output
9	TNEG	Transmit Negative Data Input
11	RNEG	Receive Positive Data Output
13	RLOS	Receive Loss-of-Signal Output

Note that the input signals in the telecom connector go from the connector to the on-board FPGA, then to the DS26334/DS26324. The FPGA was designed to perform specific signal routing functions such as looping back RPOS to TPOS on a particular port or transferring data from the on-board BERT. If you are using user-defined data and drive the signal on the connector, be sure to tri-state the input signal in the FPGA. **FAILURE TO DO SO COULD CAUSE DAMAGE TO THE FPGA!**

On-Board Bit Error-Rate Tester (BERT)

The DS26334DK has an on-board bit error-rate tester (BERT) to generate and detect errors in either pseudorandom or user-defined patterns. The BERT on the DS26334DK is the DS2174. A header for the relevant signals related to the BERT is located on the board (J22). See [Table 4](#) for the pinout of the BERT connector. The BERT signals are routed into the FPGA and can be muxed into any of the 16 DS26334/DS26324 LIU ports under software control. For all questions concerning the operation of the on-board BERT, refer to the device data sheet available online at www.maxim-ic.com/telecom. If you are using user-defined data and driver the signal on the connector, be sure to tri-state the input signal in the FPGA. **FAILURE TO DO SO COULD CAUSE DAMAGE TO THE FPGA!**

Table 4. BERT Connector Pinout

PIN	NAME	FUNCTION
1	TCLK_EN	BERT TCLK Enable
2, 4, 6, 8, 10, 12, 14	GND	Ground
3	TCLKIN	BERT TCLK Input
5	TCLKO	BERT TCLK Output
7	RCLKIN	BERT RCLK Input
9	RCLKEN	BERT RCLK Enable
11	TDAT	BERT TDAT Output
13	RDAT	BERT RDAT Input

PROM SPI Configuration

In software mode, it is possible to configure the DS26334/DS26324 using a parallel interface or a serial peripheral interface (SPI). Most advanced microcontrollers have both a parallel interface and SPI interface such as the microcontroller on the DS26334DK. The command you send to the microcontroller through either the USB or serial port determines if that data is placed on the parallel or SPI bus. Refer to the data sheet for [ChipView](#) on the particular commands required to switch data ports.

A unique feature with the SPI port is that a PROM can be used to provide the LIU with the specific data needed for configuration. If the data in the PROM is formatted a certain way, it can seem as the PROM is acting like a controller with a SPI interface in master mode.

The most common PROMs to use for this type of application are those with an internal address accumulator. This feature for the PROM is important because the device must automatically jump to the next available address in the configuration memory. The Xilinx XC18V00 device family is a byte-wide nonvolatile memory with an autoincrement address function. The family of devices is available in 1Mb, 2Mb, and 4Mb densities. The PROM is also useful because the device can perform in-circuit programming with the JTAG port. Refer the data sheet for the XC18V00 for the JTAG codes for programming the configuration memory.

[Figure 2](#) shows a general relationship of the timing for a SPI bus. For this case, all data is clocked into the slave device on the rising edge of SCLK. This feature can be configurable on the DS26334/DS26324.

Figure 2. SPI Timing Diagram

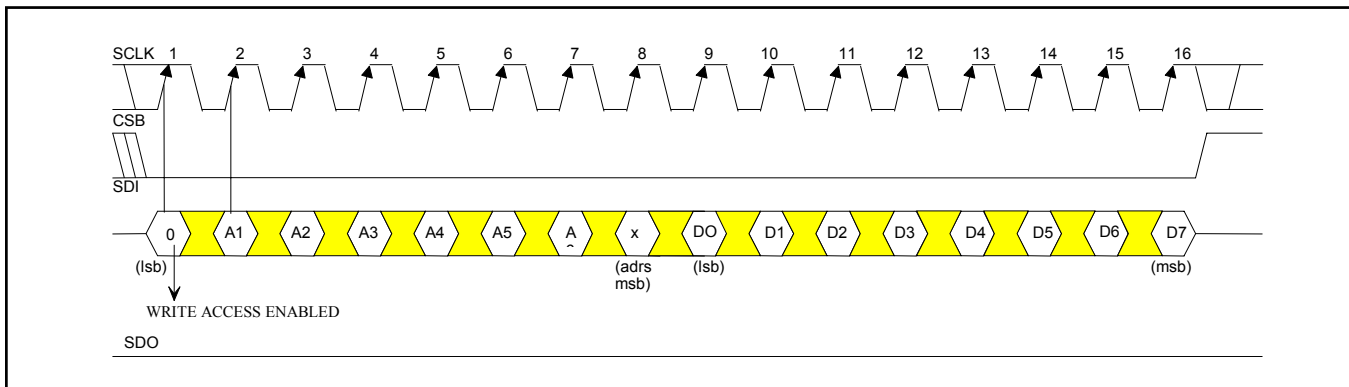

[Figure 3](#) shows a simplified diagram of the XC18V00 device and the DS26334/DS26324 in SPI (serial) mode. Notice a few key points about this diagram. First, the CLK for the XC18V00 is the MCLK for the LIU, but this is not the SCLK for the SPI interface. The SCLK can be programmed as needed. See [Table 5](#) for an example of the memory map. Second, the programming for this device begins when OE on the XC18V00 goes high. Therefore, consideration must be taken if some delay is necessary. Generally, it is sufficient for the OE pin to be connected to some power-up delay device. The OE delay is not necessary on this DK.

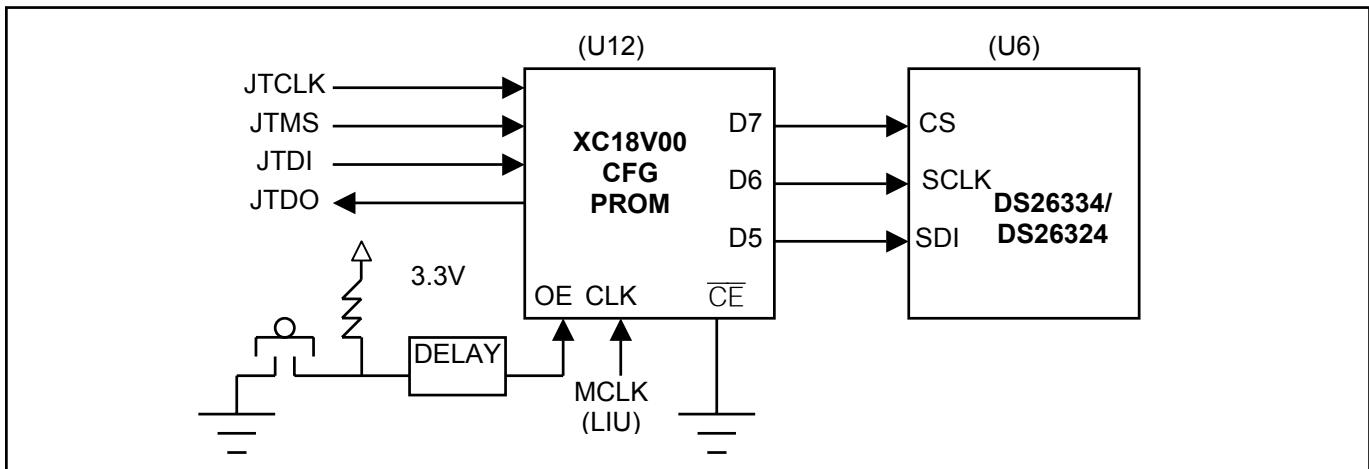
Figure 3. SPI Configuration with PROM**Table 5. Configuration Memory**

ADDRESS	D7	D6	D5	D4	D3	D2	D1	D0
	CSB	SCLK	SDI	X	X	X	X	X
0x00	1	0	0	Start of Write Cycle				
0x01	0	0	0	Bit A0				
0x02	0	1	0	(Always a "0" for a write)				
0x03	0	0	1	Bit A1				
0x04	0	1	1	Bit A2				
0x05	0	0	0	Bit A3				
0x06	0	1	0	Bit A4				
0x07	0	0	0	Bit A5				
0x08	0	1	0	Bit A6				
0x09	0	0	0	Bit A7				
0x0A	0	1	0	Bit D0 (LSB)				
0x0B	0	0	0	Bit D1				
0x0C	0	1	0	Bit D2				
0x0D	0	0	0	Bit D3				
0x0E	0	1	0	Bit D4				
0x0F	0	0	0	Bit D5				
0x10	0	1	0	Bit D6				
0x11	0	0	0	Bit D7				
0x12	0	1	0	End of Write Cycle				
0x13	0	0	1					
0x14	0	1	1					
0x15	0	0	1					
0x16	0	1	1					
0x17	0	0	0					
0x18	0	1	0					
0x19	0	0	0					
0x1A	0	1	0					
0x1B	0	0	1					
0x1C	0	1	1					
0x1D	0	0	1					
0x1E	0	1	1					
0x1F	0	0	0					
0x20	0	1	0					
0x21	1	0	X					
0x22	1	X	X					

SOFTWARE CONFIGURATION

Quick Start (Software—ChipView)

- Perform steps in the Quick Start (Hardware Configuration).
- Load ChipView software.
- Select COM port.
- Select Register View.
- From the Programs menu, launch the host application named ChipView.exe. If the default installation options were used, click the Start button on the Windows toolbar and select Programs -> ChipView -> ChipView.
- Load the DS26334DK.def file.
- Make sure that all the register settings are correct for the proper function desired for the DS26334DK.
- Refer to the DS26334 and DS26324 data sheets for all questions pertaining to device functionality.

MEMORY MAP

The on-board microcontroller is configured to start the user address space at 0x81000000. All offsets given below are relative to the beginning of the user address space.

Table 6. DS26334DK Relative Address Map

REF DES	DEVICE	OFFSET
U5	General-Purpose FPGA Tx/Rx Clock, Data Switch/Mux	0x0000
U4	DS2174 BERT	0x1000
U6	DS26334/DS26324 16-Port T1/E1/J1 LIUs	0x2000

All device registers can be easily modified using the ChipView.exe host-based user-interface software.

Table 7. General-Purpose FPGA Memory Map

OFFSET	REGISTER NAME	TYPE	DESCRIPTION
0x00	BRDID	Read-Only	Board ID
0x02	DSIDH	Read-Only	Dallas Extended ID Upper Nibble
0x03	DSIDM	Read-Only	Dallas Extended ID Middle Nibble
0x04	DSIDL	Read-Only	Dallas Extended ID Lower Nibble
0x05	BRDREV	Read-Only	Board Rev
0x06	ASMREV	Read-Only	Assembly Rev
0x07	FPGAREV	Read-Only	FPGA Firmware Rev
0x08	CTRL1	Control	Control Register 1
0x0A	ABSP	Control	Address Bank Select Pointer
0x0B	BTCLK	Control	BERT TCLK Input
0x0C	BRCLK	Control	BERT RCLK Input
0x0D	BRDAT	Control	BERT RDAT Input
0x10	TCLK	Control	Indirect Register for TCLK Source Control
0x11	TPOS	Control	Indirect Register for TPOS Source Control
0x12	TNEG	Control	Indirect Register for TPOS Source Control

ID REGISTERS

BID: BOARD ID (Offset = 0X0000)

BID is read-only with a value of 0xD.

XBIDH: HIGH NIBBLE EXTENDED BOARD ID (Offset = 0X0002)

XBIDH is read-only with a value of 0x0.

XBIDM: MIDDLE NIBBLE EXTENDED BOARD ID (Offset = 0X0003)

XBIDM is read-only with a value of 0x1.

XBIDL: LOW NIBBLE EXTENDED BOARD ID (Offset = 0X0004)

XBIDL is read-only with a value of 0x6.

BREV: BOARD FAB REVISION (Offset = 0X0005)

BREV is read-only and displays the current fab revision.

AREV: BOARD ASSEMBLY REVISION (Offset = 0X0006)

AREV is read-only and displays the current assembly revision.

PREV: FPGA REVISION (Offset = 0X0007)

PREV is read-only and displays the current PLD firmware revision.

CONTROL REGISTERS

Register Name: **CTRL_1**

Register Description: **DS26334DK FPGA CONTROL REGISTER 1**

Register Offset: **0x08**

Bit #	7	6	5	4	3	2	1	0
Name	ENRLOS16	ENRLOS15	CLKE	SPI_SWAP	SPI	OE	MCLK1	MCLK0

Bit 7: ENRLOS16. This bit enables the RLOS16 LED. This should not be enabled when driving TECLK from the DS26334/DS26324.

If ENRLOS16 = LOW, the RLOS16 LED is not enabled.

If ENRLOS16 = HIGH, the RLOS16 LED is enabled and lights when RLOS16 is high.

Bit 6: ENRLOS15. This bit enables the RLOS15 LED. This should not be enabled when driving CLKA from the DS26334/DS26324.

If ENRLOS15 = LOW, the RLOS15 LED is not enabled.

If ENRLOS15 = HIGH, the RLOS15 LED is enabled and lights when RLOS15 is high.

Bit 5: CLKE. This bit sets the CLKE pin on the DS26334/DS26324. This is only active when SPI (Bit 0) is HIGH. If SPI (Bit 0) is low, CLKE is always low.

If CLKE = LOW, SDO is clocked out on the rising edge of SCLK.

If CLKE = HIGH, SDO is clocked out on the falling edge of SCLK.

Bit 4: SPI_SWAP. This bit sets the BSWP/A5 pin on the DS26334/DS26324. This is only active when SPI (Bit 0) is HIGH.

If SPI_SWAP = LOW, the SPI bus is LSB first.

If SPI_SWAP = HIGH, the SPI bus is MSB first.

Bit 3: SPI. This bit sets up the FPGA to use serial mode. This bit also changes the mode pin on the DS26334/DS26324.

If SPI = LOW, the parallel bus is used for all read/write access. This also sets the MODE pin on the DS26334/DS26324 to logic 1.

If SPI = HIGH, the SPI bus is used for all read/write access. This also sets the MODE pin on the DS26334/DS26324 to logic 0.

Bit 2: OE. This bit controls the OE pin to the DS26334.

Bits 1 and 0: MCLK1 and MCLK0. These bits control the MCLK pin to the DS26334/DS26324.

MCLK1	MCLK0	DESCRIPTION OF MCLK
0	0	MCLK = high-impedance mode
0	1	MCLK = on-board T1 oscillator
1	0	MCLK = on-board E1 oscillator
1	1	MCLK = user clock input

Register Name: **ABSP**Register Description: **ADDRESS BANK SWAP POINTER**Register Offset: **0x0A**

Bit #	7	6	5	4	3	2	1	0
Name	D7	D6	D5	D4	D3	D2	D1	D0

Bits 7 to 0: D7 to D0. These bits control the address bank for address 0x10 (TCLK N), 0x11 (TPOS), and 0x12 (TNEG).

ABSP	DESCRIPTION
0x00	Bank Address Value for Port 1
0x01	Bank Address Value for Port 2
0x02	Bank Address Value for Port 3
0x03	Bank Address Value for Port 4
0x04	Bank Address Value for Port 5
0x05	Bank Address Value for Port 6
0x06	Bank Address Value for Port 7
0x07	Bank Address Value for Port 8
0x08	Bank Address Value for Port 9
0x09	Bank Address Value for Port 10
0x0A	Bank Address Value for Port 11
0x0B	Bank Address Value for Port 12
0x0C	Bank Address Value for Port 13
0x0D	Bank Address Value for Port 14
0x0E	Bank Address Value for Port 15
0x0F	Bank Address Value for Port 16

Register Name: **BTCLK**
 Register Description: **BERT TCLK SOURCE**
 Register Offset: **0x0B**

Bit #	7	6	5	4	3	2	1	0
Name	D7	D6	D5	D4	D3	D2	D1	D0

Bits 7 to 0: D7 to D0. These bits control the source of the TCLK for the BERT.

BTCLK	DESCRIPTION
0x00	RCLK Port 1
0x01	RCLK Port 2
0x02	RCLK Port 3
0x03	RCLK Port 4
0x04	RCLK Port 5
0x05	RCLK Port 6
0x06	RCLK Port 7
0x07	RCLK Port 8
0x08	RCLK Port 9
0x09	RCLK Port 10
0x0A	RCLK Port 11
0x0B	RCLK Port 12
0x0C	RCLK Port 13
0x0D	RCLK Port 14
0x0E	RCLK Port 15
0x0F	RCLK Port 16
0x10	1.544MHz On-board oscillator
0x11	2.048MHz On-board oscillator
0x12	User clock
0x13	CLKA DS26334
0x14	TECLK DS26334
0x15	TCLKBERT OUT
0x16–0xFF	HI-Z

Register Name: **BRCLK**Register Description: **BERT RCLK SOURCE**Register Offset: **0x0C**

Bit #	7	6	5	4	3	2	1	0
Name	D7	D6	D5	D4	D3	D2	D1	D0

Bits 7 to 0: D7 to D0. These bits control the source of the RCLK for the BERT.

BTCLK	DESCRIPTION
0x00	RCLK Port 1
0x01	RCLK Port 2
0x02	RCLK Port 3
0x03	RCLK Port 4
0x04	RCLK Port 5
0x05	RCLK Port 6
0x06	RCLK Port 7
0x07	RCLK Port 8
0x08	RCLK Port 9
0x09	RCLK Port 10
0x0A	RCLK Port 11
0x0B	RCLK Port 12
0x0C	RCLK Port 13
0x0D	RCLK Port 14
0x0E	RCLK Port 15
0x0F	RCLK Port 16
0x10	1.544MHz On-board oscillator
0x11	2.048MHz On-board oscillator
0x12	User clock
0x13	CLKA DS26334/DS26324
0x14	TECLK DS26334/DS26324
0x15	TCLKBERT OUT
0x16–0xFF	HI-Z

Register Name: **BRDAT**
 Register Description: **BERT RDAT SOURCE**
 Register Offset: **0x0D**

Bit #	7	6	5	4	3	2	1	0
Name	D7	D6	D5	D4	D3	D2	D1	D0

Bits 7 to 0: D7 to D0. These bits control the source of the RDAT for the BERT. Note that the DS26334/DS26324 must be in single-rail mode for BERT to function properly.

BRDAT	DESCRIPTION
0x00	RPOS Port 1
0x01	RPOS Port 2
0x02	RPOS Port 3
0x03	RPOS Port 4
0x04	RPOS Port 5
0x05	RPOS Port 6
0x06	RPOS Port 7
0x07	RPOS Port 8
0x08	RPOS Port 9
0x09	RPOS Port 10
0x0A	RPOS Port 11
0x0B	RPOS Port 12
0x0C	RPOS Port 13
0x0D	RPOS Port 14
0x0E	RPOS Port 15
0x0F	RPOS Port 16
0x10	1.544MHz On-board oscillator
0x11	2.048MHz On-board oscillator
0x12	User clock
0x13	CLKA DS26334/DS26324
0x14	TECLK DS26334/DS26324
0x15	TCLKBERT OUT
0x16–0xFF	HI-Z

Register Name: **TCLK**
 Register Description: **PORT TCLK SOURCE**
 Register Offset: **0x10**

Bit #	7	6	5	4	3	2	1	0
Name	D7	D6	D5	D4	D3	D2	D1	D0

Note: This is an indirect register that is related to ABSP (0x0A). See register description.

Bits 7 to 0: D7 to D0. These bits control the source of the port TCLK for the DS26334/DS26324.

TCLK	DESCRIPTION
0x00	RCLK Port 1
0x01	RCLK Port 2
0x02	RCLK Port 3
0x03	RCLK Port 4
0x04	RCLK Port 5
0x05	RCLK Port 6
0x06	RCLK Port 7
0x07	RCLK Port 8
0x08	RCLK Port 9
0x09	RCLK Port 10
0x0A	RCLK Port 11
0x0B	RCLK Port 12
0x0C	RCLK Port 13
0x0D	RCLK Port 14
0x0E	RCLK Port 15
0x0F	RCLK Port 16
0x10	1.544MHz On-board oscillator
0x11	2.048MHz On-board oscillator
0x12	User clock
0x13	CLKA DS26334/DS26324
0x14	TECLK DS26334/DS26324
0x15	TCLKBERT OUT
0x16–0xFF	HI-Z

Register Name: **TPOS**
 Register Description: **PORT TPOS SOURCE**
 Register Offset: **0x11**

Bit #	7	6	5	4	3	2	1	0
Name	D7	D6	D5	D4	D3	D2	D1	D0

Note: This is an indirect register that is related to ABSP (0x0A). See register description.

Bits 7 to 0: D7 to D0. These bits control the source of the port TPOS for the DS26334/DS26324.

TPOS	DESCRIPTION
0x00	RPOS Port 1
0x01	RPOS Port 2
0x02	RPOS Port 3
0x03	RPOS Port 4
0x04	RPOS Port 5
0x05	RPOS Port 6
0x06	RPOS Port 7
0x07	RPOS Port 8
0x08	RPOS Port 9
0x09	RPOS Port 10
0x0A	RPOS Port 11
0x0B	RPOS Port 12
0x0C	RPOS Port 13
0x0D	RPOS Port 14
0x0E	RPOS Port 15
0x0F	RPOS Port 16
0x10	1.544MHz On-board oscillator
0x11	2.048MHz On-board oscillator
0x12	User clock
0x13	CLKA DS26334/DS26324
0x14	TECLK DS26334/DS26324
0x15	TDATBERT OUT
0x16–0xFF	HI-Z

Register Name: **TNEG**
 Register Description: **PORT TNEG SOURCE**
 Register Offset: **0x12**

Bit #	7	6	5	4	3	2	1	0
Name	D7	D6	D5	D4	D3	D2	D1	D0

Note: This is an indirect register that is related to ABSP (0x0A). See register description.

Bits 7 to 0: D7 to D0. These bits control the source of the port TNEG for the DS26334/DS26324.

TNEG	DESCRIPTION
0x00	RNEG Port 1
0x01	RNEG Port 2
0x02	RNEG Port 3
0x03	RNEG Port 4
0x04	RNEG Port 5
0x05	RNEG Port 6
0x06	RNEG Port 7
0x07	RNEG Port 8
0x08	RNEG Port 9
0x09	RNEG Port 10
0x0A	RNEG Port 11
0x0B	RNEG Port 12
0x0C	RNEG Port 13
0x0D	RNEG Port 14
0x0E	RNEG Port 15
0x0F	RNEG Port 16
0x10	1.544MHz On-board oscillator
0x11	2.048MHz On-board oscillator
0x12	User clock
0x13	CLKA DS26334/DS26324
0x14	TECLK DS26334/DS26324
0x15	Drive Logic "0"
0x16-0xFF	HI-Z

DS26334 INFORMATION

For more information about the DS26334, refer to the DS26334 data sheet available on our website at www.maxim-ic.com/DS26334.

DS26324 INFORMATION

For more information about the DS26324, refer to the DS26324 data sheet available on our website at www.maxim-ic.com/DS26324.

DS26334DK/DS26324DK INFORMATION

For more information about the DS26334DK/DS26324DK including software downloads, go to www.maxim-ic.com/DS26334DK.

TECHNICAL SUPPORT

For additional technical support, go to www.maxim-ic.com/support.

ERRATA

On page 18 of the schematic, EB0 and EB1 were swapped in the design on U3 and U10, respectively. These changes have been made to the board using jumper wires.

SCHEMATICS

The DS26334DK/DS26324DK schematics are featured in the following 25 pages.

DS26334 DESIGN KIT
SCHEMATIC

DALLAS SEMICONDUCTOR / MAXIM

MAY 2005

TABLE OF CONTENTS

1. COVER PAGE	9. LIU FRONT END PORTS 9-12	17. ON BOARD MICRO	25. PART CROSS REF P-2
2. DS26334 CONTROL	10. LIU FRONT END PORTS 13-16	18. SRAM	
3. DS26334 PORTS 1-4	11. RLOS, INT LEDs, PROG CLKS	19. TEST POINTS	
4. DS26334 PORTS 5-8	12. EBERT x 1 / SPI PROM	20. LIU SERIES TERMINATION	
5. DS26334 PORTS 9-12	13. FPGA CONTROL, FLASH CFG	21. DECOUPLING CAPS	
6. DS26334 PORTS 13-16	14. FPGA BANK 1	22. MISC.	
7. LIU FRONT END PORTS 1-4	15. FPGA BANK 2	23. SIGNAL CROSS REF	
8. LIU FRONT END PORTS 5-8	16. USB AND JTAG CONN	24. PART CROSS REF P-1	

TITLE:	COVER PAGE	DATE:	
ENGINEER:	DS26334DK	PAGE:	1

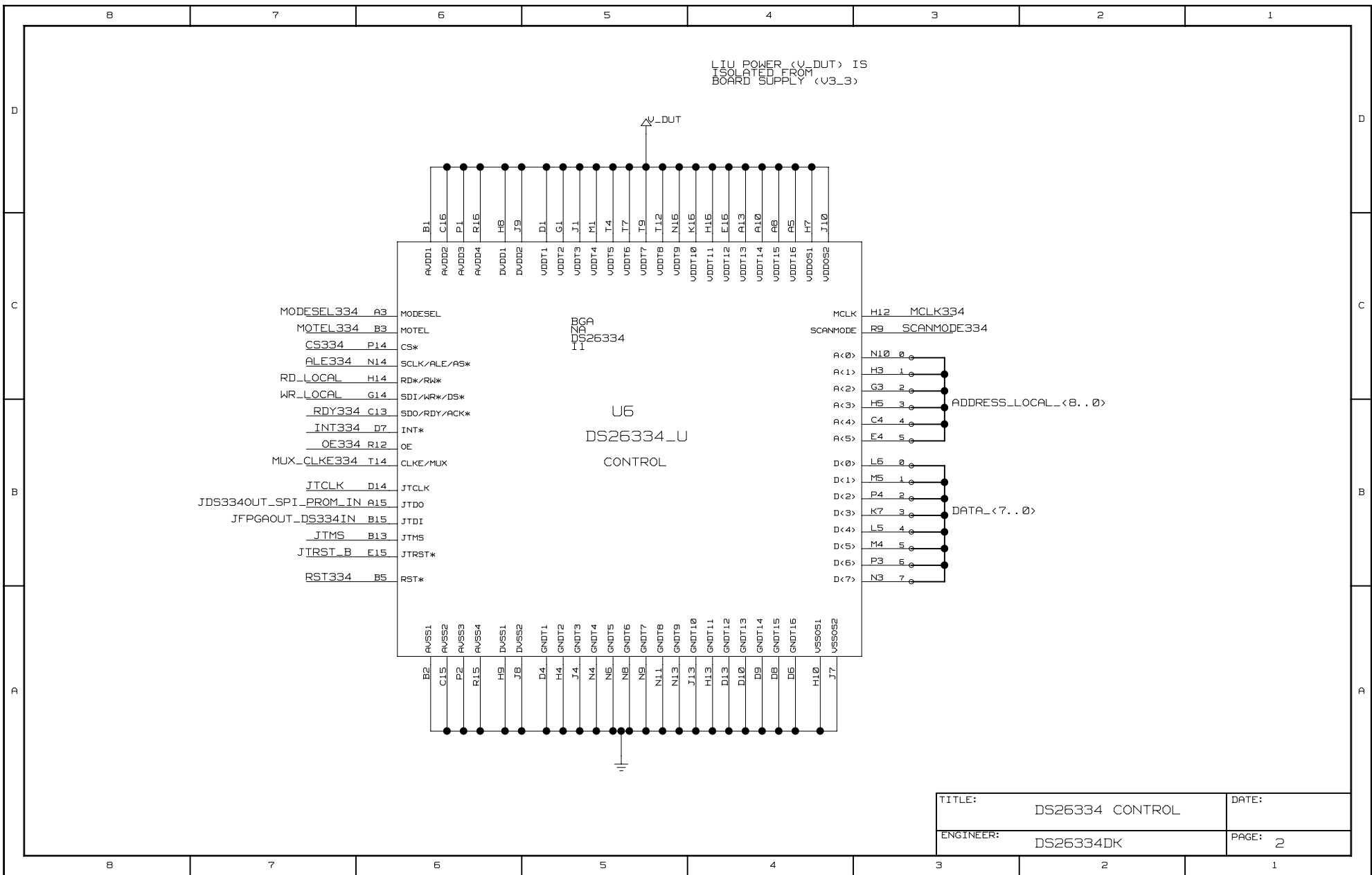

TITLE:	DS26334 CONTROL	DATE:	
ENGINEER:	DS26334DK	PAGE:	2

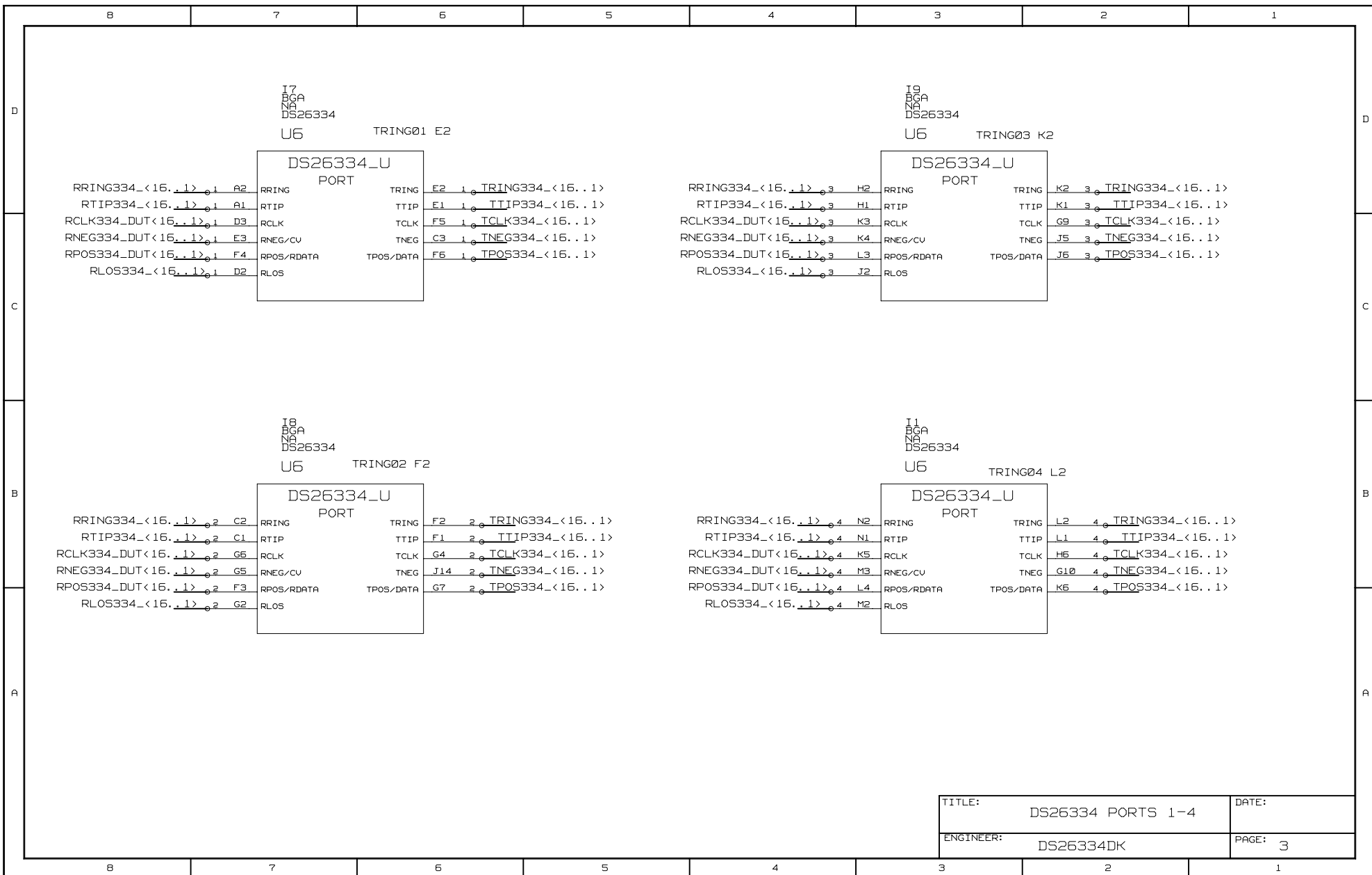

TITLE:	DS26334 PORTS 1-4	DATE:	
ENGINEER:	DS26334DK	PAGE:	3

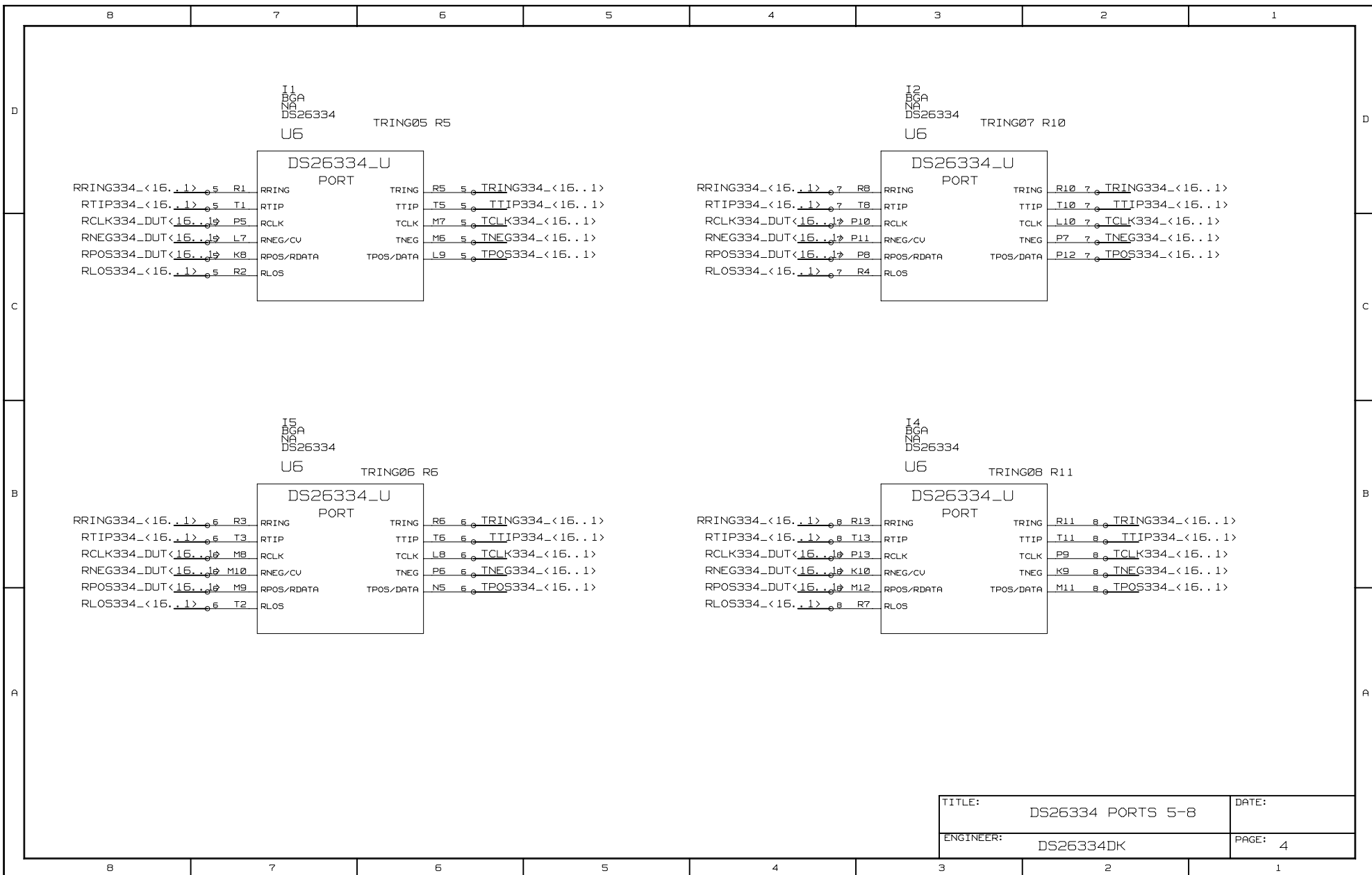

TITLE:	DS26334 PORTS 5-8	DATE:	
ENGINEER:	DS26334DK	PAGE:	4

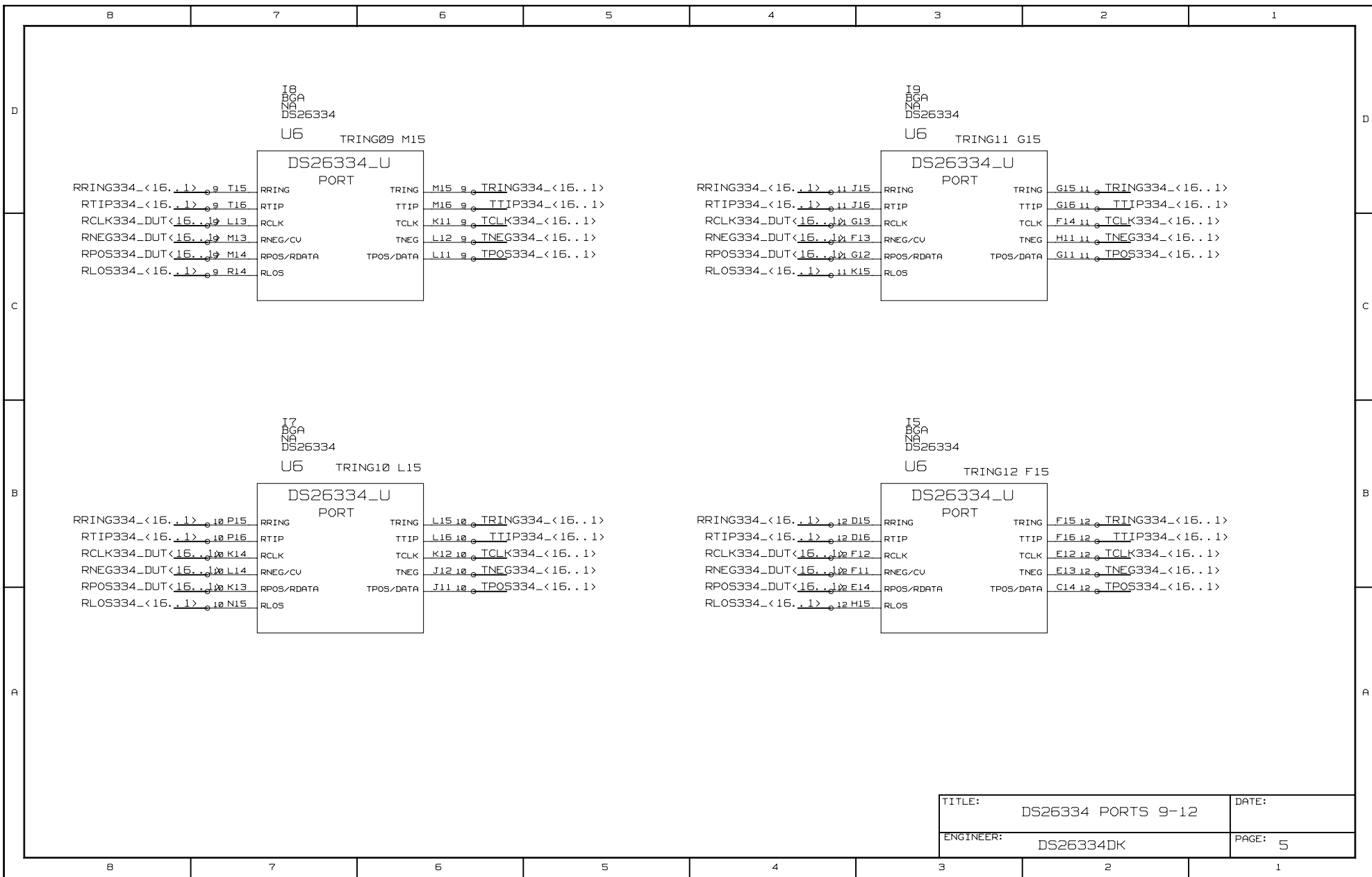

TITLE:	DS26334 PORTS 9-12	DATE:	
ENGINEER:	DS26334DK	PAGE:	5

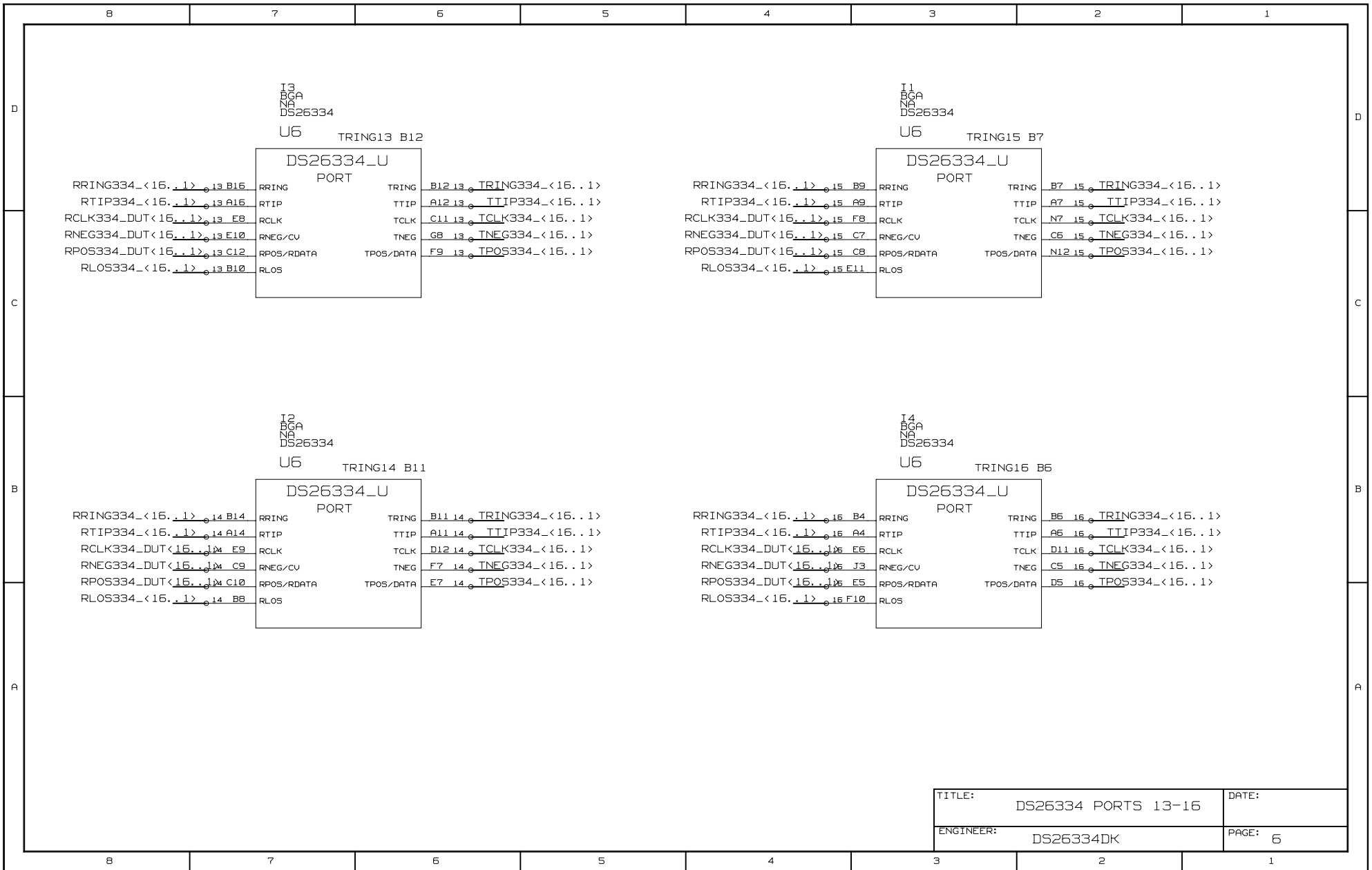

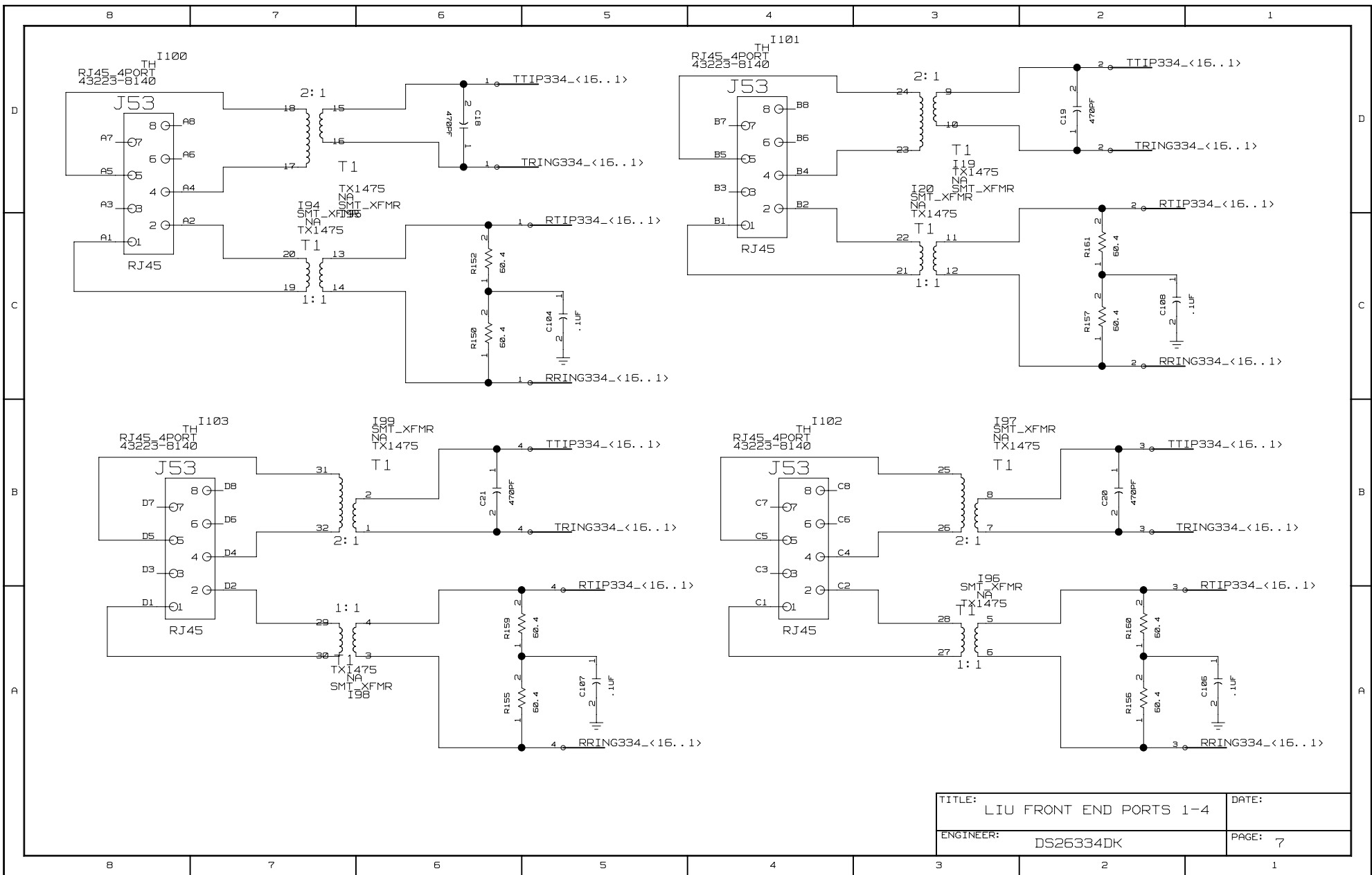

TITLE: LIU FRONT END PORTS 1-4	DATE:
ENGINEER: DS26334DK	PAGE: 7

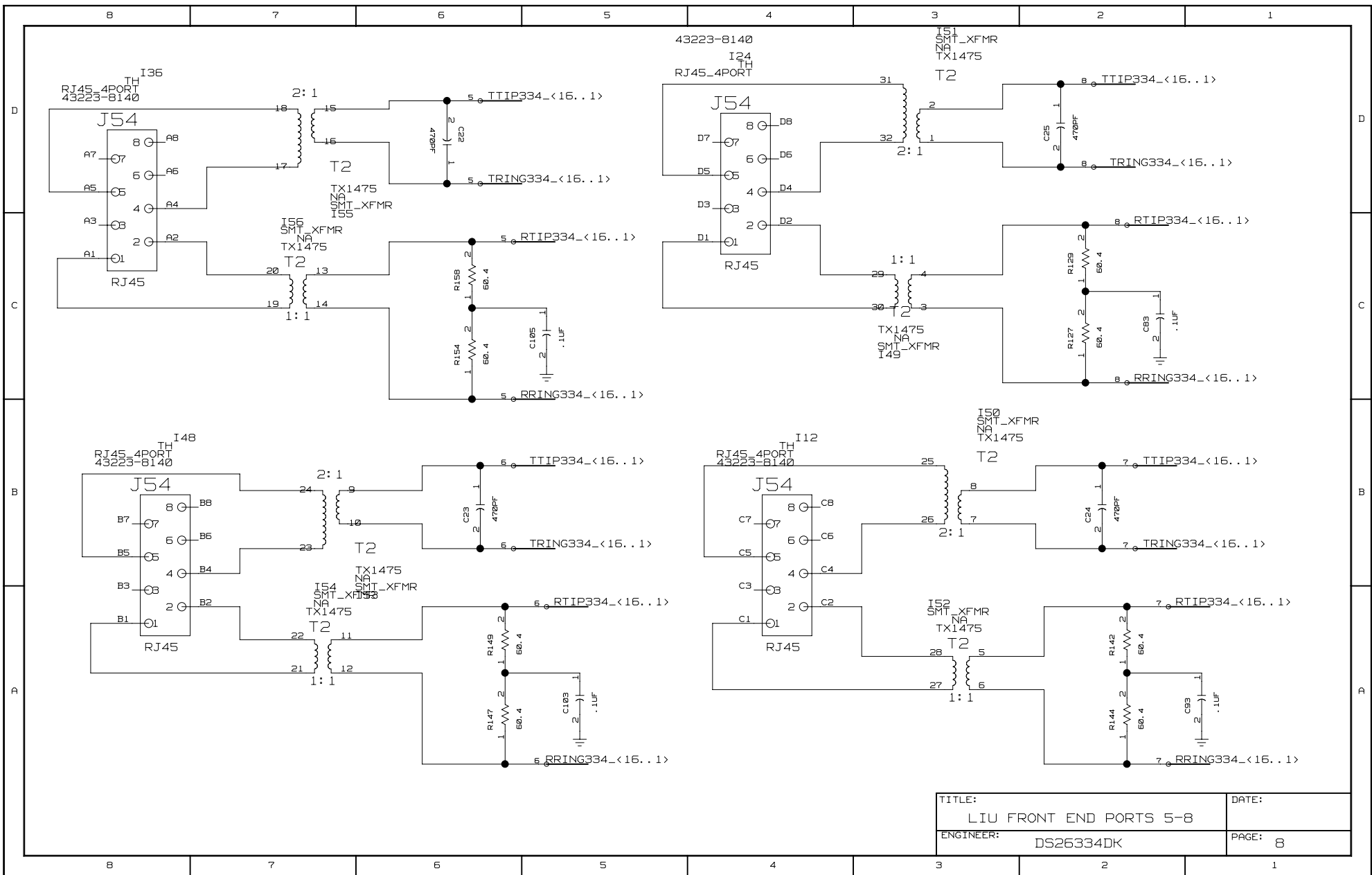

TITLE: LIU FRONT END PORTS 5-8	DATE:
ENGINEER: DS26334DK	PAGE: 8

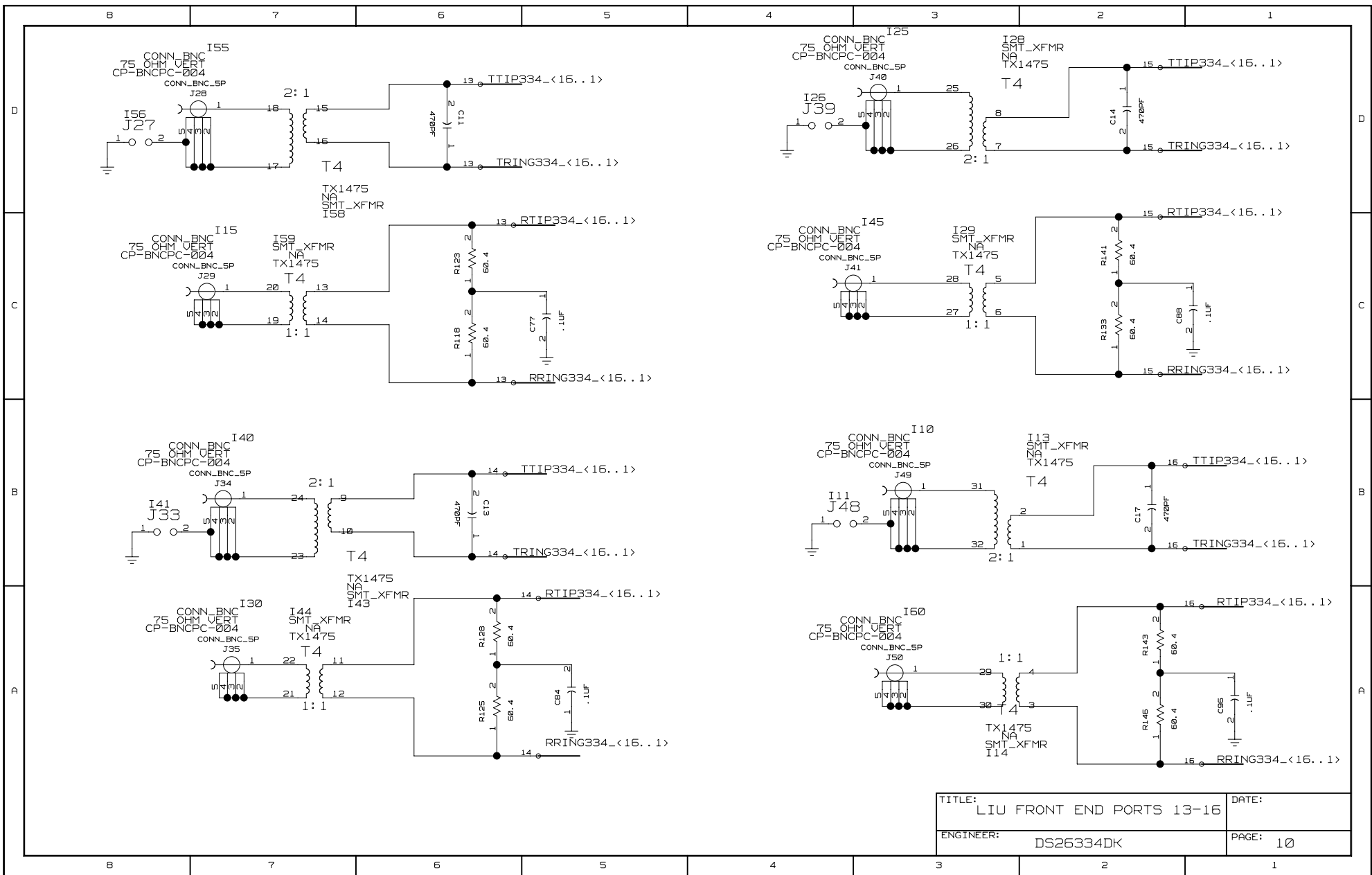

TITLE: LIU FRONT END PORTS 13-16	DATE:
ENGINEER: DS26334DK	PAGE: 10

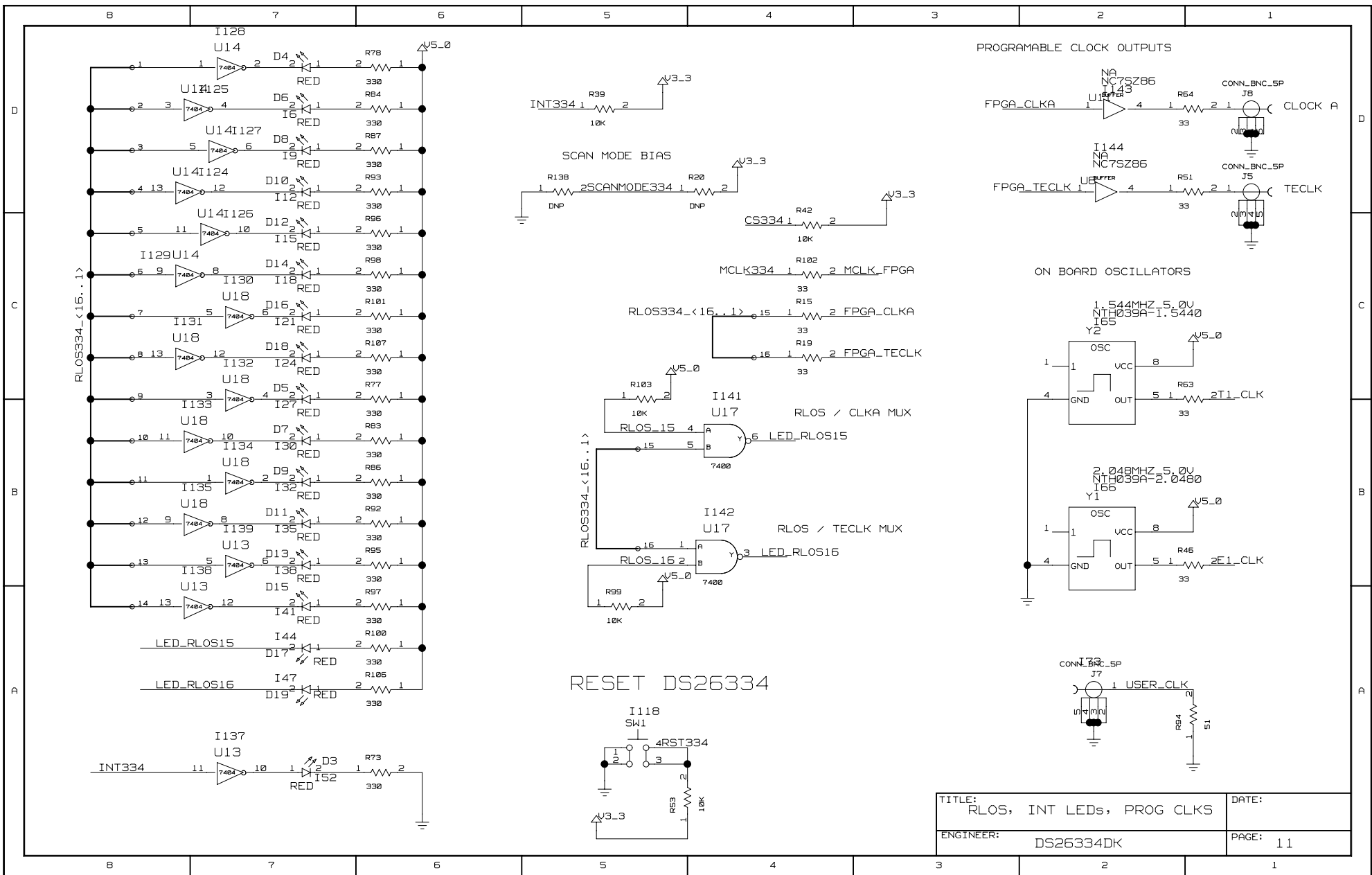

TITLE: RLOS, INT LEDs, PROG CLKS	DATE:
ENGINEER: DS26334DK	PAGE: 11

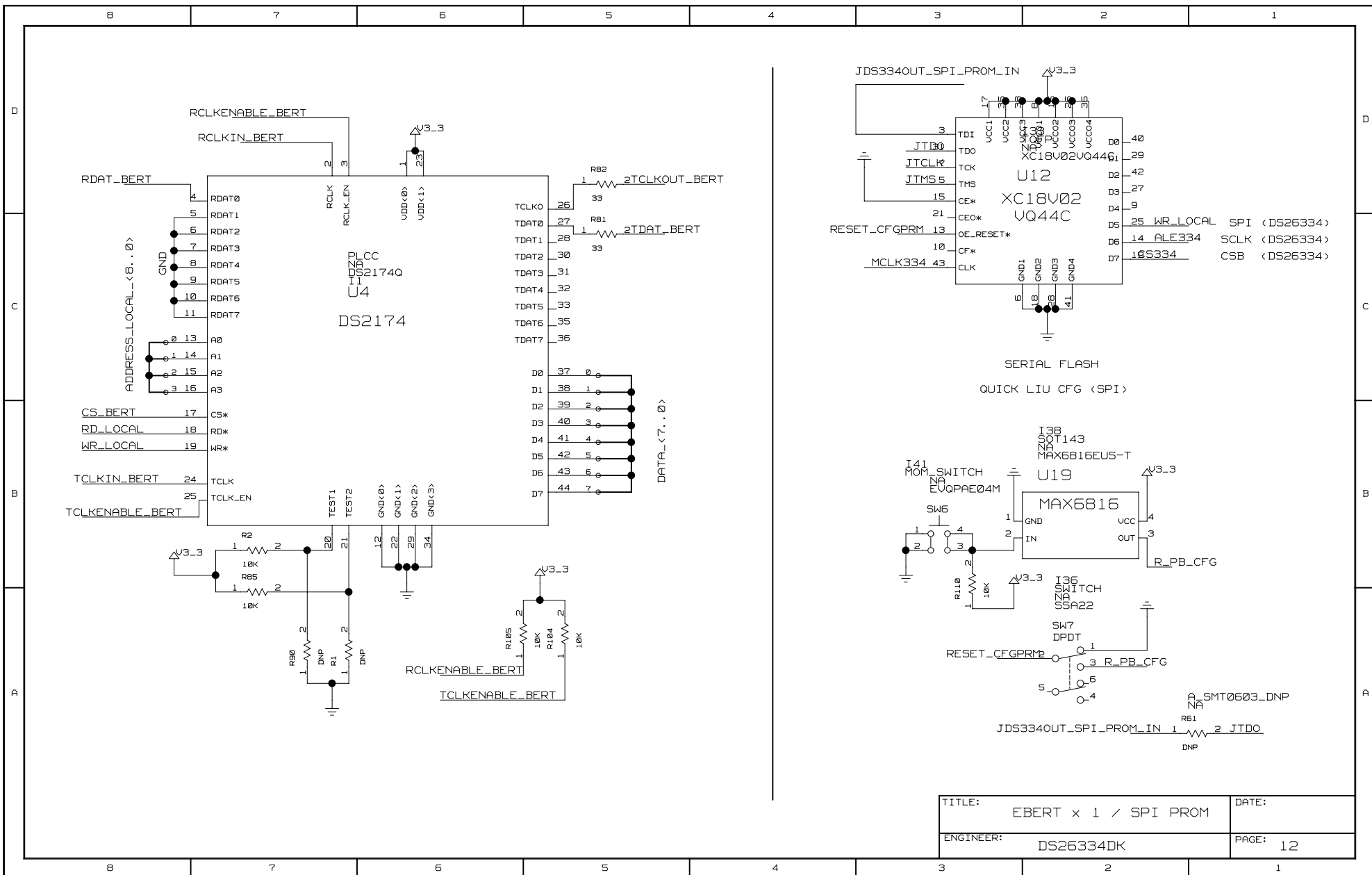

TITLE:	EBERT x 1 / SPI PROM	DATE:	
ENGINEER:	DS26334DK	PAGE:	12

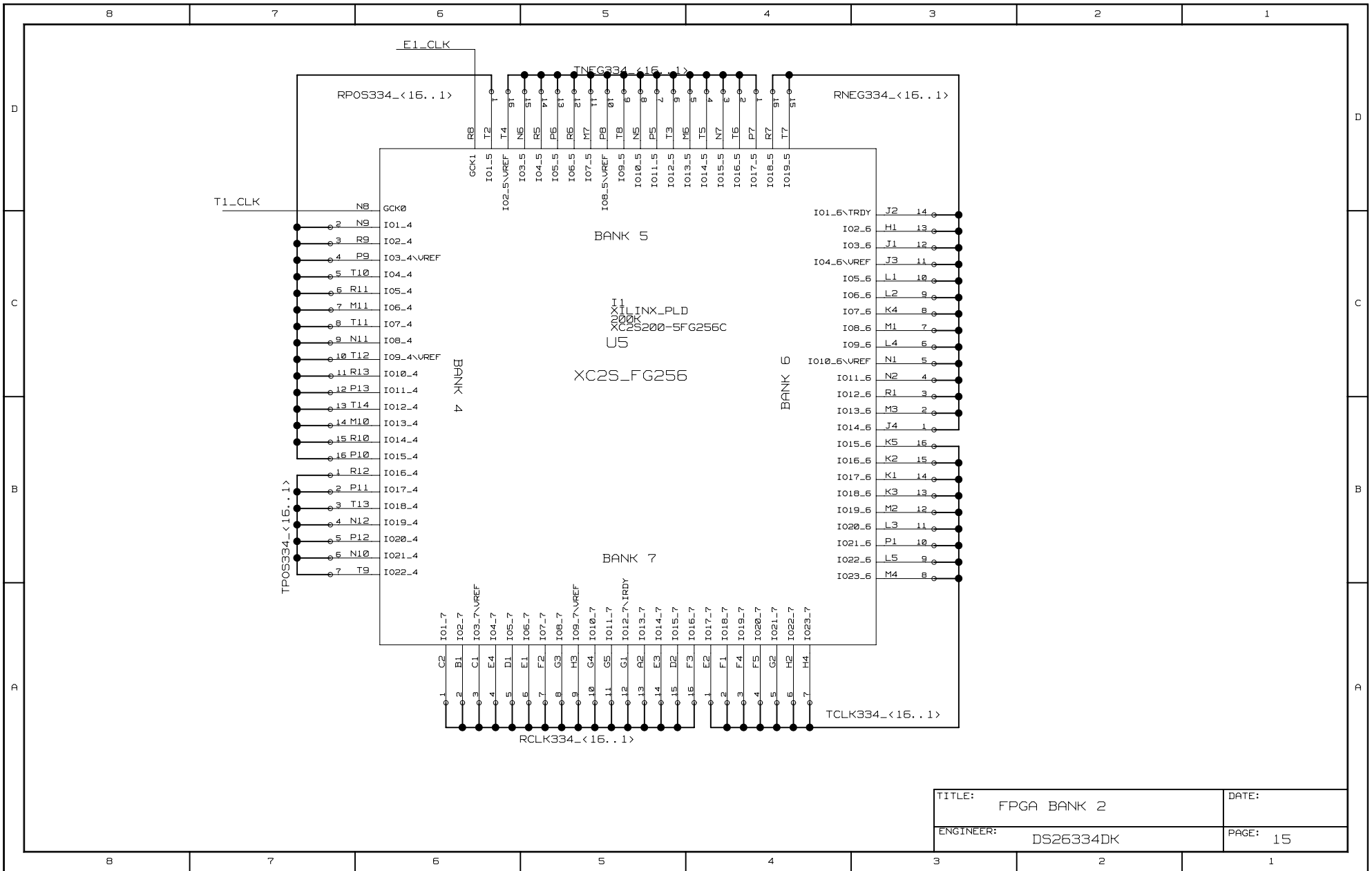

TITLE:	FPGA BANK 2	DATE:	
ENGINEER:	DS26334DK	PAGE:	15

USB INTERFACE

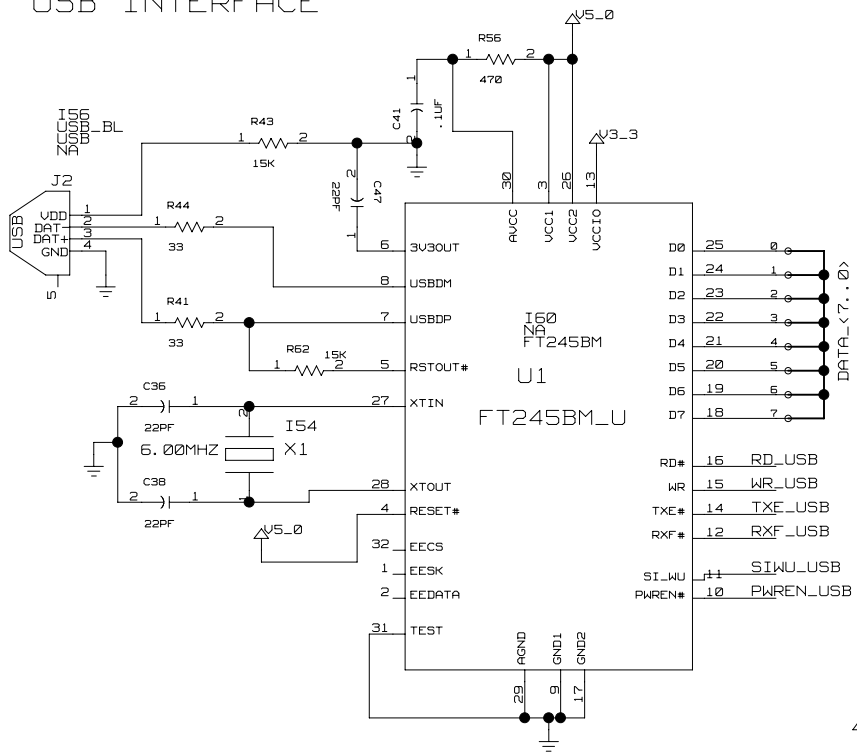

BOARD JTAG HEADER

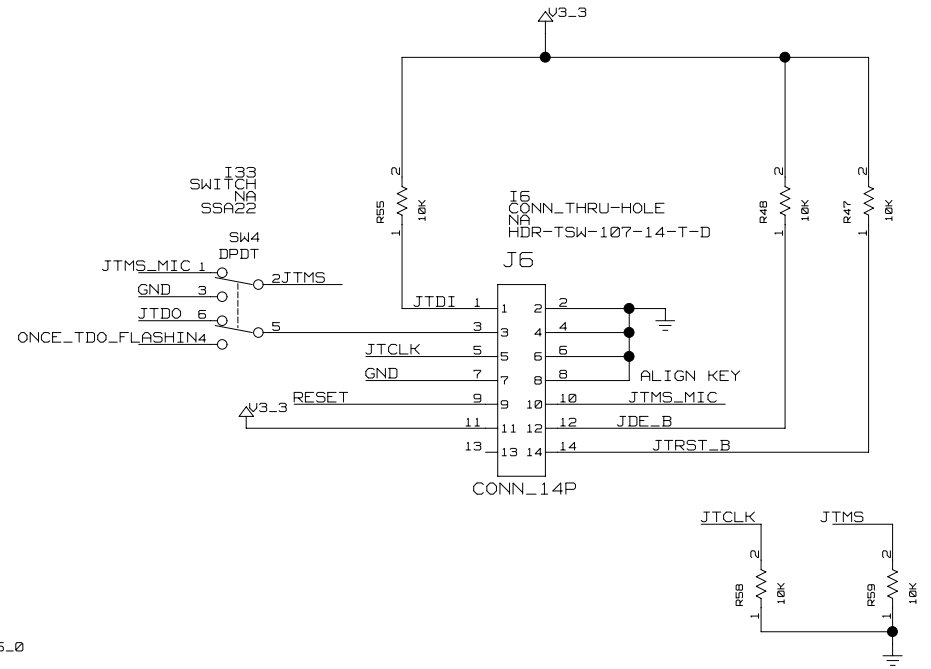

RS232 INTERFACE

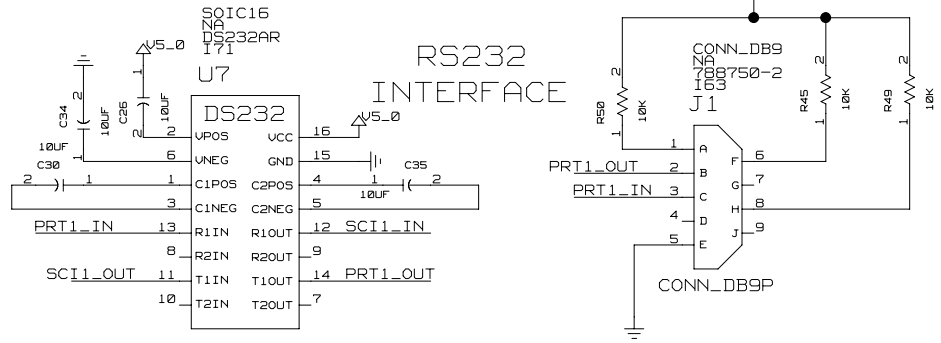

TITLE: USB AND JTAG CONN	DATE:
ENGINEER: DS26334DK	PAGE: 16

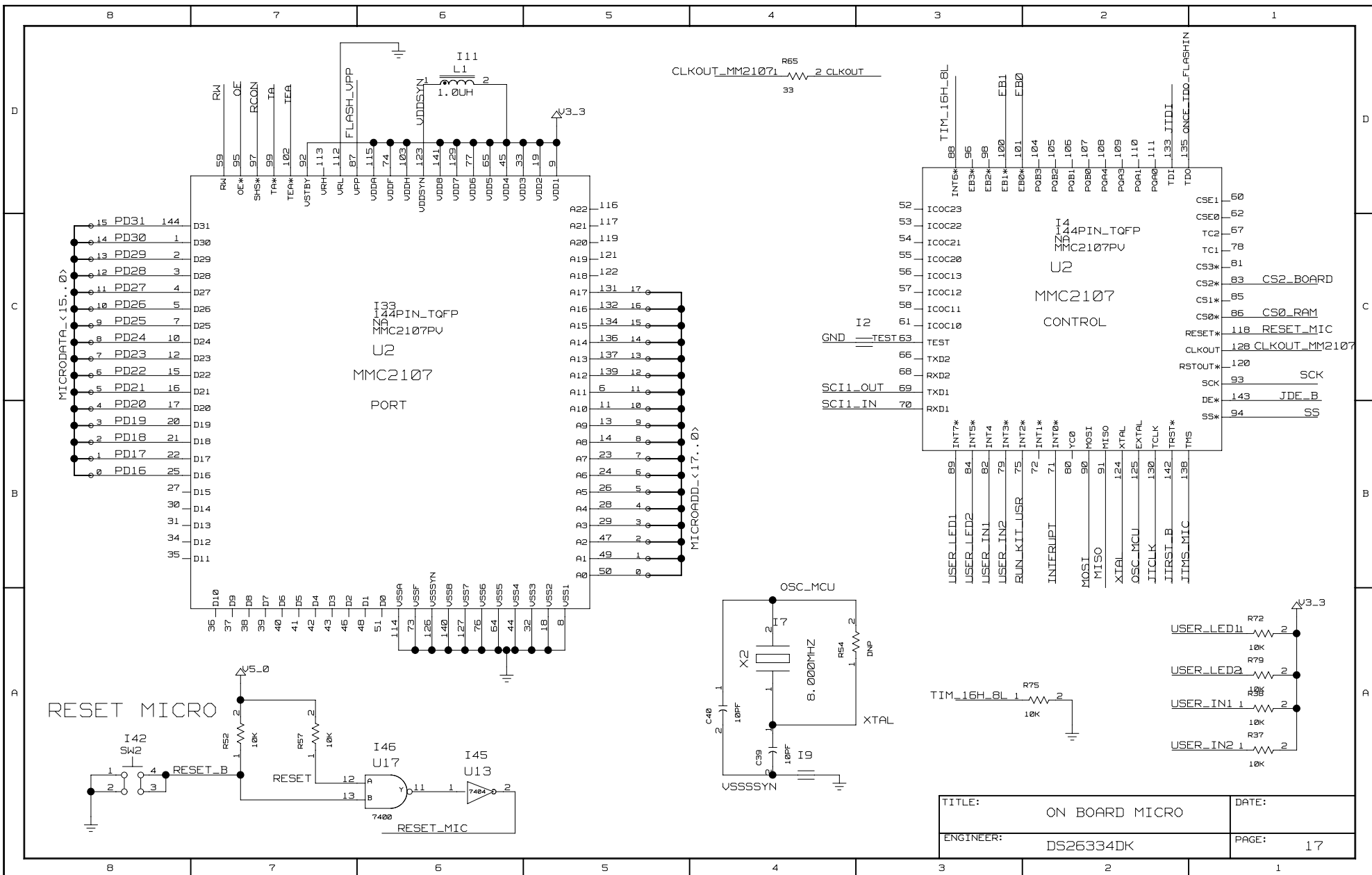

TITLE:	ON BOARD MICRO	DATE:	
ENGINEER:	DS26334DK	PAGE:	17

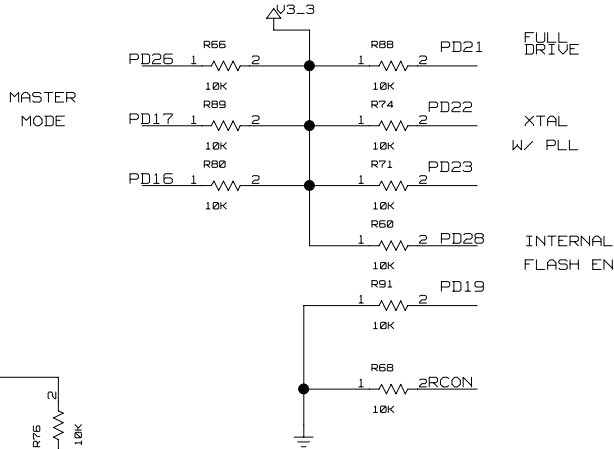
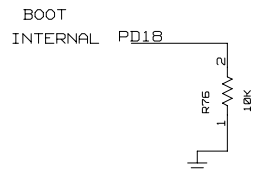
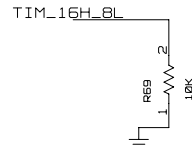
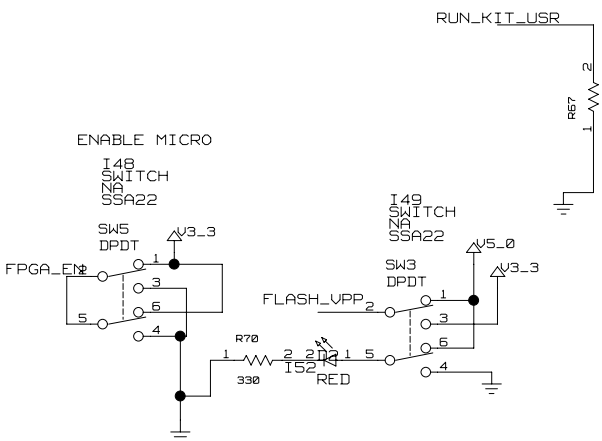
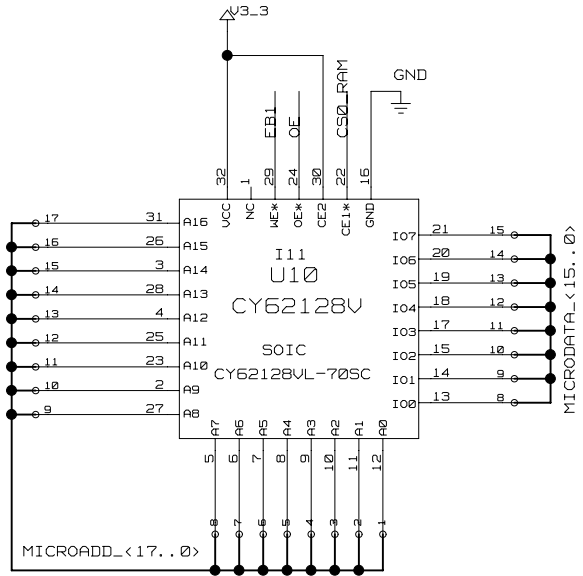
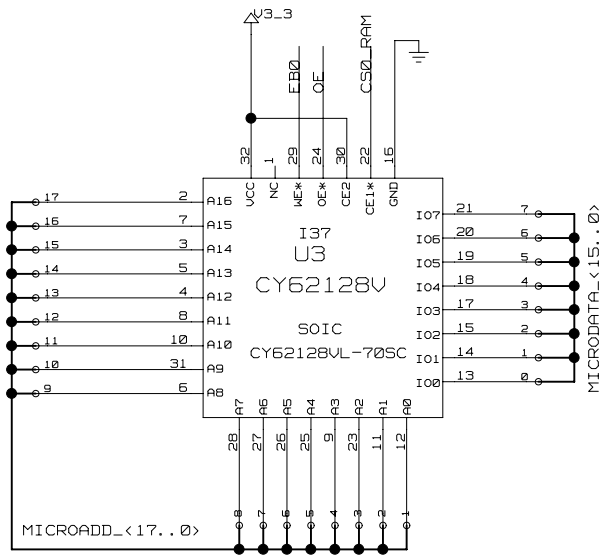

TITLE:	SRAM	DATE:	
ENGINEER:	DS26334DK	PAGE:	18

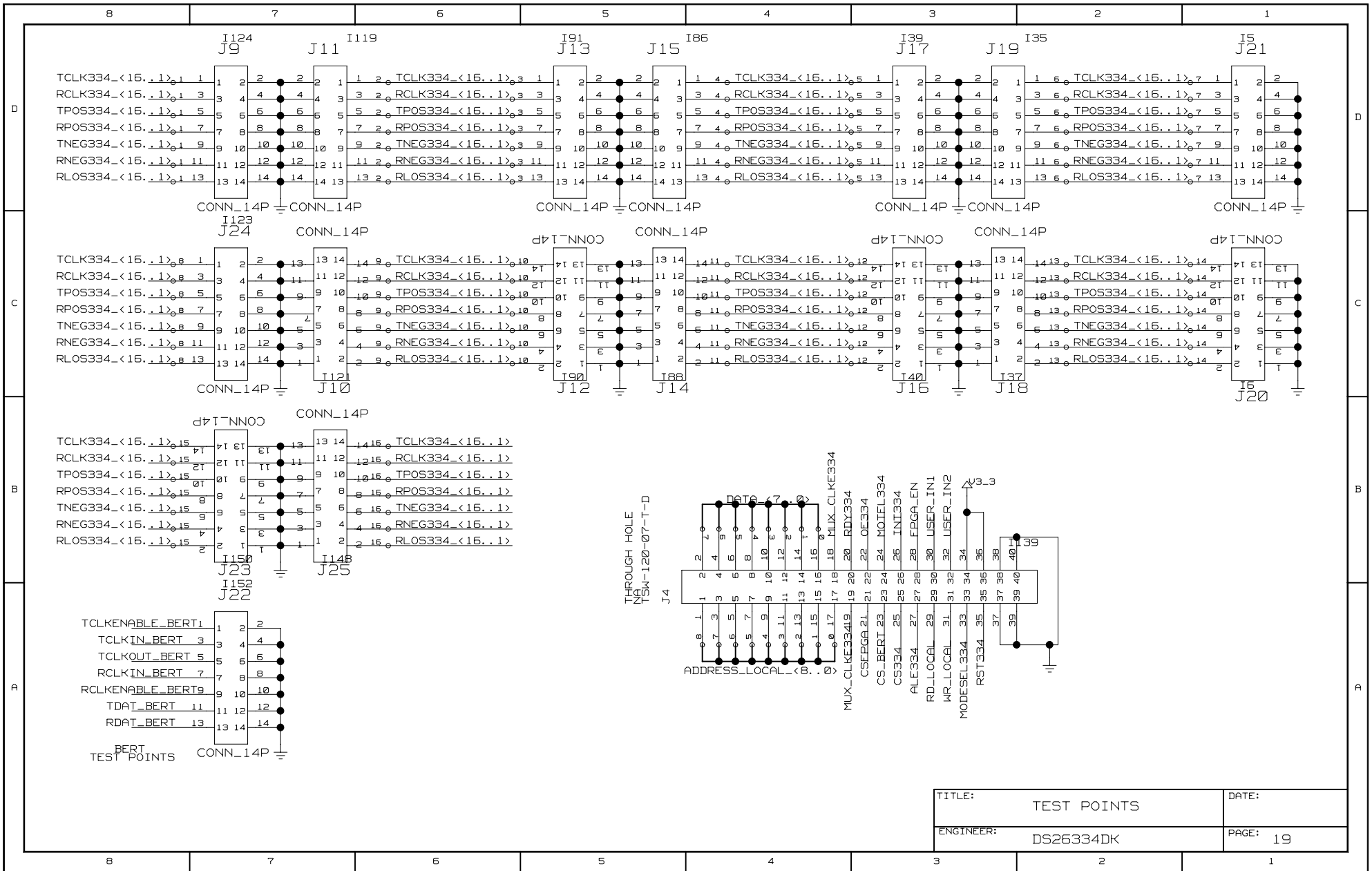

TITLE:	TEST POINTS	DATE:
ENGINEER:	DS26334DK	PAGE: 19

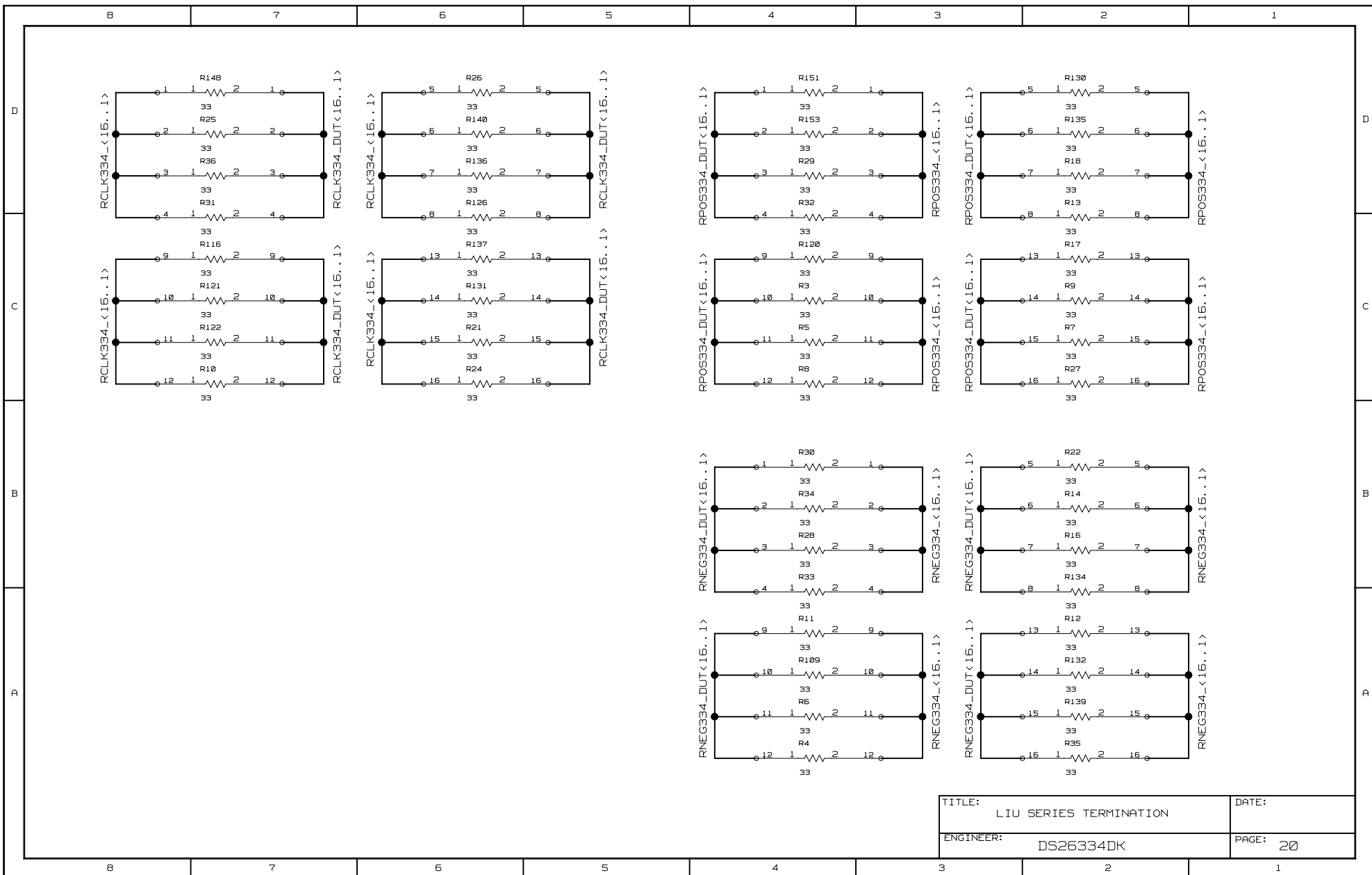

TITLE:	LIU SERIES TERMINATION	DATE:	
ENGINEER:	DS26334DK	PAGE:	20

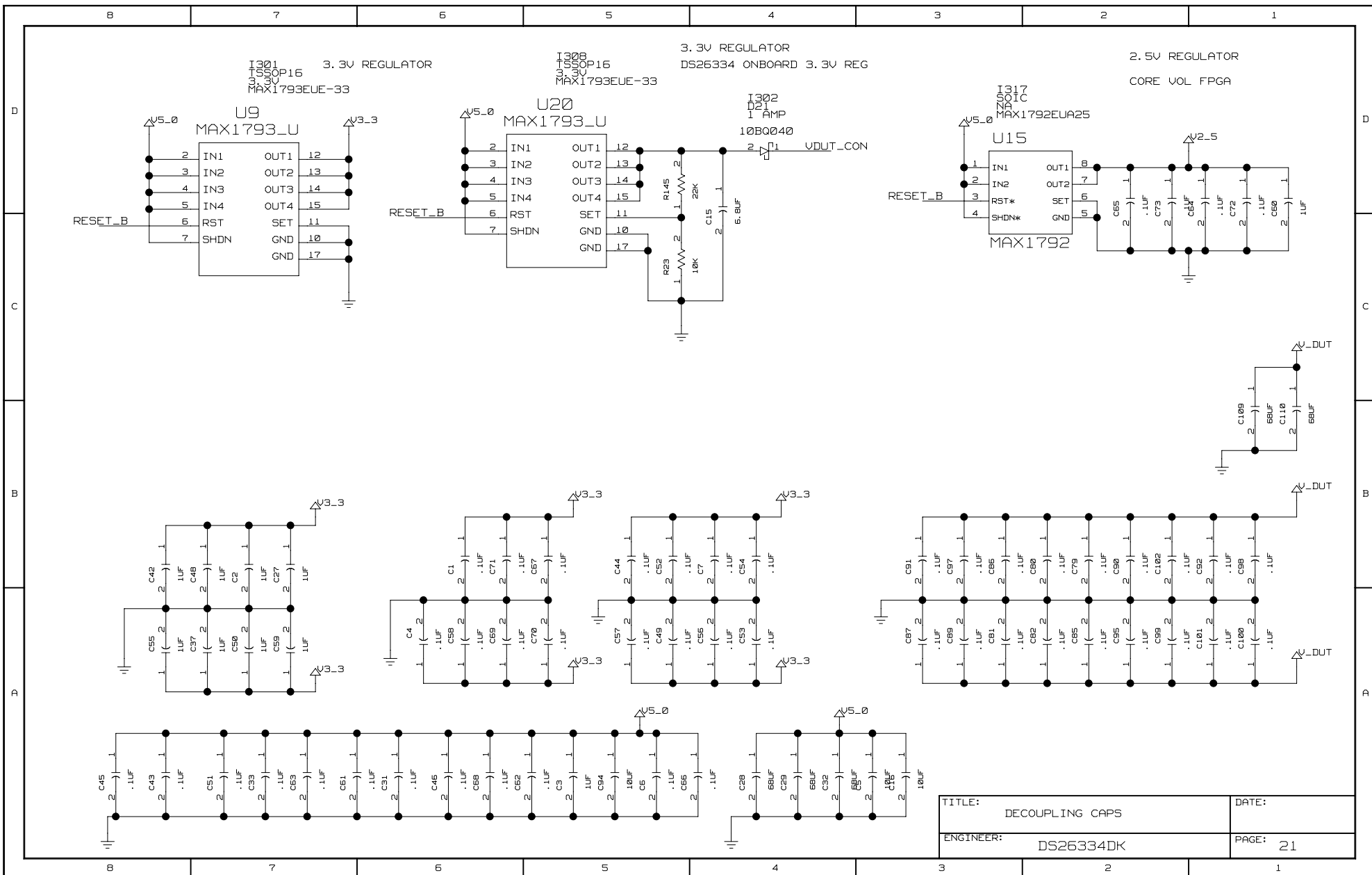

TITLE:	DECOUPLING CAPS	DATE:	
ENGINEER:	DS26334DK	PAGE:	21

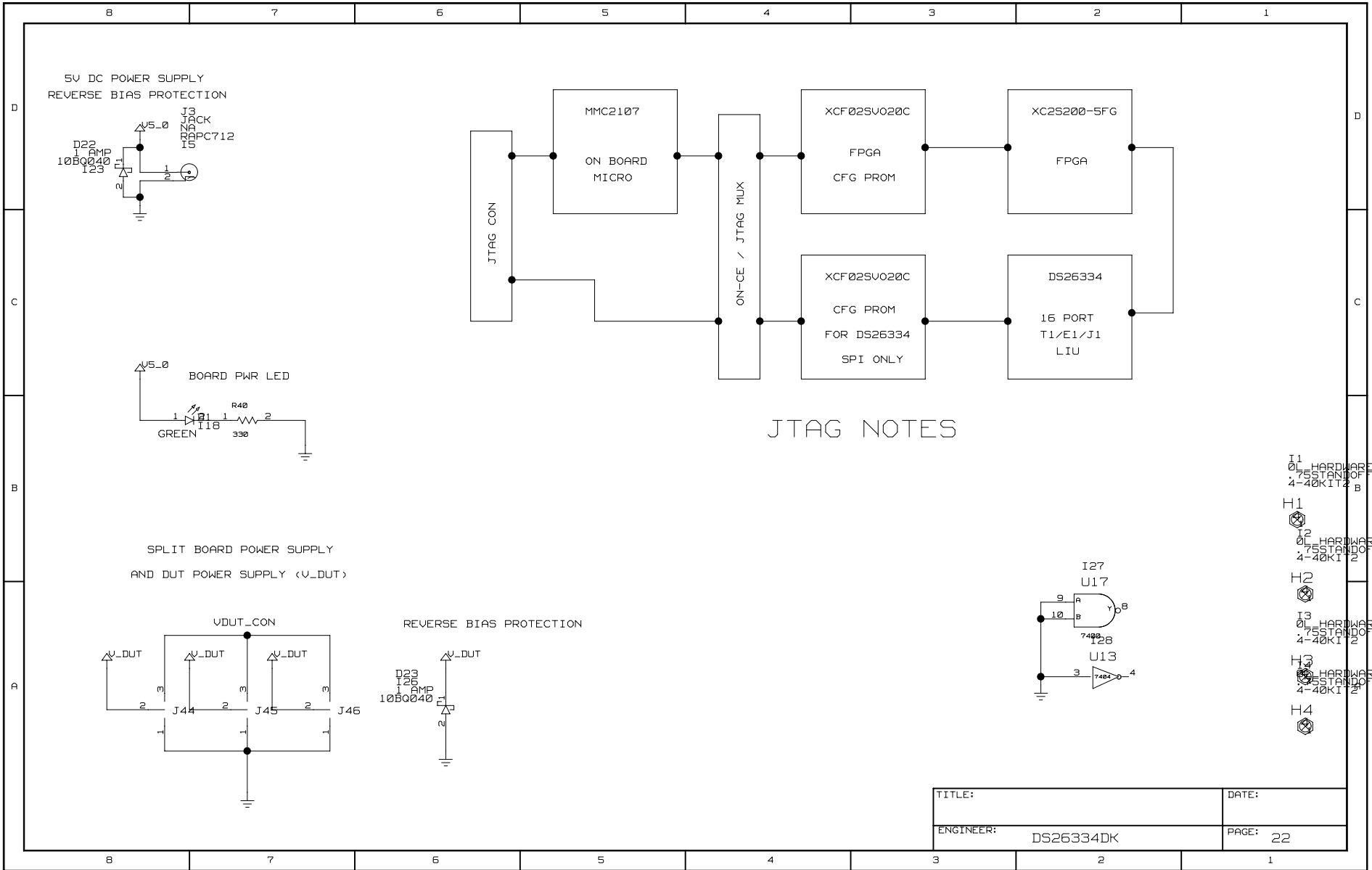

JTAG NOTES

- I1 0L HARDWARE STANDOFF --.25SSCR 4-40KIT 2
- H1 0L HARDWARE STANDOFF --.25SSCR 4-40KIT 2
- I2 0L HARDWARE STANDOFF --.25SSCR 4-40KIT 2
- H2 0L HARDWARE STANDOFF --.25SSCR 4-40KIT 2
- I3 0L HARDWARE STANDOFF --.25SSCR 4-40KIT 2
- H3 0L HARDWARE STANDOFF --.25SSCR 4-40KIT 2
- I4 0L HARDWARE STANDOFF --.25SSCR 4-40KIT 2
- H4 0L HARDWARE STANDOFF --.25SSCR 4-40KIT 2

TITLE:	DATE:
ENGINEER: DS26334DK	PAGE: 22

	8	7	6	5	4	3	2	1	
D	<pre> *** Signal Cross-Reference for the entire design *** ADDRESS_LOCAL.<B..0> 2B3 12C8 14D5 19A5 ALE334 12C1 14B7<> 19A3<> 2C7< CLK_A 13B3<> 13B1< CFG_DIN_A 13B1 14B3<> CLKOUT 14D7< 17D3< CLKOUT_MM2107 17C1<> 17D4< CS0_RAH 17C1<> 18D3< 18D6< CS2_BOARD 14A4<> 17C1<> CS334 12C1 14B7<> 19A3<> 2C7< 11C4< CSFFGA 14B7<> 19A3<> CS_BERT 14B7<> 19A3<> 12B8< DATA.<7..0> 2B3 12B5 14C3 16C5 19B4 DONE_FPGA_A 13B3<> 13A3< 13B1< E1_CLK 11B1< 15D6< EB0 14A4<> 17D3<> 18D7< EB1 14A4<> 17D3<> 18D3< FLASH_VFP 18B7<> 17D7< FPGA_CLKA 11D3<> 14C3<> 11C3< FPGA_EN 14B7<> 18A8<> 19B3<> FPGA_TECLK 11D3<> 14B3<> 11C3< INT334 2B7< 14C3<> 19B3<> 11A8< 11D5< INTERUPT 14B3<> 17B2< JDE_B 16B2<> 17B1< JDS334OUT_SPI_PROM_IN 2B7< 12A2< 12D3< JFLASHOUT_FPGA_IN 13B1 13C3< JFPGAOUT_DS334IN 13C3< 2B7< JTCLK 12D3< 16C3<> 17B2<> 2B7< 13B3< 13C3< 15B2< JTDI 16C3<> 17D2<> JTDO 12D3 16C4<> 12A1< JTMS 16C3<> 2B7< 12D3< 13B3< 13C3< 16B1< JTMS_MIC 16B2<> 16C4<> 17B2<> JTRST_B 16B2<> 17B2<> 2B7< 11A8<> 11B4< LED_RLOS15 11A8<> 11B4< MCLK334 2C3< 11C4< 12C3< MCLK_FPGA 14C3<> 11C3< MICROADD.<17..0> 14B7 17B4 18B4 18B8 MICRODATA.<15..0> 14A5 17B8 18C2 18C5 MISO 14B7<> 17A2<> MODESEL334 14B3<> 19A3<> 2C7< MOSI 14B7<> 17A2<> MOTEL334 14B3<> 19B3<> 2C7< MUX_CLKE334 14B3<> 19A4<> 19B4<> 2B7< OE 14A4<> 17D7<> 18D3< 18D7< QE334 14B3<> 19B3<> 2B7< ONCE_TDO_FLASHIN 16C4<> 17D2<> 13B3< OSC_MCU 17B2<> 17B4<> PD15 17B8<> 18B3< PD17 17B8<> 18B3< PD18 17B8<> 18A4< PD19 17B8<> 18A2< PD20 17B8<> PD21 17C8<> 18B2< PD22 17C8<> 18B2< PD23 17C8<> 18B2< PD24 17C8<> PD25 17C8<> PD26 17C8<> 18B3< PD27 17C8<> PD28 17C8<> 18A2< PD29 17C8<> PD30 17C8<> PD31 17C8<> PROGRAM_FPGA_A 13B1 13B3< PRT1_IN 16A6< 16A8< PRT1_OUT 16A6< 16A6< PWREN_USB 14D4< 16B5< RCLK334.<16..1> 19B6 15A6 19B8< 19C2 19C4 19C6 19C8< 19D2 19D4 19D6 19D8< 20C6 20C6 20C8 20C8 RCLK334_DUT.<16..1> 3B5< 3B8< 3C5< 3C8< 4B4< 4B8< 4C4< 4C8< 5B4< 5B8< 5C4< 5C8< 6B4< 6B8< 6C5< 6C8< 20C5 20C5 20C7 20C7 </pre>		<pre> RCLKENABLE_BERT 14A6<> 19A8<> 12A6< 12D7< RCLKIN_BERT 14A6<> 19A8<> 12D7< RCON 14A4<> 17D7<> 18A2< RDAT_BERT 14A6<> 19A8<> 12D8< RDY334 2B7< 14B3<> 19B4<> RD_LOCAL 14B7<> 19A3<> 2C7< 12B8< RD_USB 14A6<> 16C5< RESET 16B3<> 17A7< RESET_B 13B1<> 17A8<> 21C5< 21C8< 21D3< RESET_CFGPM 12B3<> 12C3< RESET_MIC 17A6 17C1< RLOS334.<16..1> 19B6 3A4< 3A8< 3C4< 3C8< 4A4< 4A8< 4C4< 4C8< 5A4< 5A8< 5C4< 5C8< 6A4< 6A8< 6C4< 6C8< 11B5 11C5 11C8 19B8< 19C2 19C4 19C6 19C8< 19D2 19D4 19D6 19D8< RLOS_15 14D4<> 11B5< RLOS_16 14D4<> 11B5< RNEG334.<16..1> 19B6 15D4 19B8< 19C2 19C4 19C6 19C8< 19D2 19D4 19D6 19D8< 20A1 20A3 20B1 20B3 RNEG334_DUT.<16..1> 3B5< 3B8< 3C5< 3C8< 4B4< 4B8< 4C4< 4C8< 5B4< 5B8< 5C4< 5C8< 6B4< 6B8< 6C5< 6C8< 20A9 20A4 20B3 20B4 RPOS334.<16..1> 19B6 15D7 19B8< 19C2 19C4 19C6 19C8< 19D2 19D4 19D6 19D8< 20C1 20C1 20C3 20C3 RPOS334_DUT.<16..1> 3B5< 3B8< 3C5< 3C8< 4B4< 4B8< 4C4< 4C8< 5B4< 5B8< 5C4< 5C8< 6B4< 6B8< 6C5< 6C8< 20C3 20C3 20C4 20C4 RRING334.<16..1> 7A1 7A4< 7C1< 7C5< 8A1 8A5< 8B5< 8C1 9A1 9A5 9C1 9C5 10A1 10A5 10C1 10C5 3B4< 3B8< 3D5< 3D8< 4B4< 4B8< 4D4< 4D8< 5B4< 5B8< 5D4< 5D8< 6B4< 6B8< 6D4< 6D8< RST334 11A5<> 14A3<> 19A3<> 2B7< RTIP334.<16..1> 7B1 7B4< 7C1 7C5 8A1 8A5 8C1 8C5 9A5 9B1 9C1 9C5 10A1 10A5 10C1 10C5 3B4< 3B8< 3C4< 3C8< 4B4< 4B8< 4C4< 4C8< 5B4< 5B8< 5C4< 5C8< 6B4< 6B8< 6C4< 6C8< RUN_KIT_USR 17B3<> 18B6< RW 14A4<> 17D7<> RXF_USB 14B3<> 16B5< R_PB_CFG 12A2<> 12B2< SCANMODE334 2C3< 11D5< SC11_IN 16A6 17B4<> SC11_OUT 17C4<> 16A8< SCK 14B7<> 17C1<> SIW_USB 14D4< 16B5< SS 14B7<> 17B1<> T1_CLK 11B1 15C7< TA 14A3<> 17D7<> CLK334.<16..1> 3B1 3B5 3C1 3C5 4B1 4B5 4C1 4C5 5B1 5B5 5C1 5C5 6B1 6B5 6C1 6C5 19B6 15A4 19B8< 19C2 19C4 19C6 19C8< 19D2 19D4 19D6 19D8< TCLKENABLE_BERT 14A6<> 19A8<> 12A6< 12B8< TCLKIN_BERT 14A6<> 19A8<> 12B8< TCLKOUT_BERT 14A6<> 19A8<> 12D5< TDAT_BERT 14A6<> 19A8<> 12C5< TEA 14A3<> 17D7<> TEST 17C3<> TIM_16H_8L 17D3<> 17A3 18B5< TNEG334.<16..1> 3B1 3B5 3C1 3C5 4B1 4B5 4C1 4C5 5B1 5B5 5C1 5C5 6B1 6B5 6C1 6C5 19B6 15D5 19B8< 19C2 19C4 19C6 19C8< 19D2 19D4 19D6 19D8< TPOS334.<16..1> 3B1 3B5 3C1 3C5 4B1 4B5 4C1 4C5 5B1 5B5 5C1 5C5 6B1 6B5 6C1 6C5 19B6 14D5 15A7 19B8< 19C2 19C4 19C6 19C8< 19D2 19D4 19D6 19D8< </pre>		<pre> TRING334.<16..1> 3B1 3B5 3D1 3D5 4B1 4B5 4D1 4D5 5B1 5B5 5D1 5D5 6B1 6B5 6D1 6D5 7B1 7B5 7D1 7D5 8B1 8B5 8D1 8D5 9B1 9B5 9D1 9D5 10B1 10B5 10D1 10D5 TTIP334.<16..1> 3B1 3B5 3C1 3C5 4B1 4B5 4C1 4C5 5B1 5B5 5C1 5C5 6B1 6B5 6C1 6C5 7B1 7B5 7D1 7D5 8B1 8B5 8D1 8D5 9B1 9B5 9D1 9D5 10B1 10B5 10D1 10D5 TXE_USB 14B3<> 16B5< USER_CLK 11A2<> 14C7< USER_IN1 17B3<> 19B3<> 17A2< USER_IN2 17B3<> 19B3<> 17A2< USER_LED1 17B3<> 17A2< USER_LED2 17B3<> 17A2< VDDSYN 17D6< VDDUT_CON 21D4<> 22A7<> VSSSYN 17A4< WR_LOCAL 12C1 14A7<> 19A3<> 2B7< 12B8< WR_USB 14A4< 16B5< XTAL 17A3<> 17B2<> </pre>		D		
C									C
B									B
A									A
	8	7	6	5	4	3	2	1	
							TITLE:	DATE:	
							ENGINEER:	PAGE:	

	8	7	6	5	4	3	2	1	
D	R115 RES1 9A2 R116 RES1 20C7 R117 RES1 9A2 R118 RES1 10C6 R119 RES1 9C6 R120 RES1 20C4 R121 RES1 20C7 R122 RES1 20C7 R123 RES1 10C6 R124 RES1 9C6 R125 RES1 10A6 R126 RES1 20D6 R127 RES1 8C2 R128 RES1 10A6 R129 RES1 8C2 R130 RES1 20D2 R131 RES1 20C6 R132 RES1 20A2 R133 RES1 10C2 R134 RES1 20B2 R135 RES1 20D2 R136 RES1 20D6 R137 RES1 20C6 R138 RES1 11D5 R139 RES1 20A2 R140 RES1 20D6 R141 RES1 10C2 R142 RES1 8A2 R143 RES1 10A2 R144 RES1 8A2 R145 RES1 21D5 R146 RES1 10A2 R147 RES1 8A6 R148 RES1 20D7 R149 RES1 8A6 R150 RES1 7C6 R151 RES1 20D4 R152 RES1 7C6 R153 RES1 20D4 R154 RES1 8C6 R155 RES1 7A6 R156 RES1 7A2 R157 RES1 7C2 R158 RES1 8C6 R159 RES1 7A6 R160 RES1 7A2 R161 RES1 7C2 SW1 PUSHBUTTON 11A5 SW2 PUSHBUTTON 17A8 SW3 SWITCH_DPDT_SLIDE_6P 18A6 SW4 SWITCH_DPDT_SLIDE_6P 16C4 SW5 SWITCH_DPDT_SLIDE_6P 18A8 SW6 PUSHBUTTON 12B3 SW7 SWITCH_DPDT_SLIDE_6P 12A2 T1 XFMR_QUADTIE1_TG83_U 7A3 7A7 7B3 7B6 7C3 7C7 7D3 7D7 T2 XFMR_QUADTIE1_TG83_U 8A3 8A7 8B3 8B7 8C3 8C7 8D3 8D7 T3 XFMR_QUADTIE1_TG83_U 9A3 9A7 9B2 9B7 9C3 9C7 9D2 9D7 T4 XFMR_QUADTIE1_TG83_U 10A3 10A7 10B2 10B7 10C3 10C7 10D3 10D7 U1 FT245BM_U 16C6 U2 MMC2107_1 17C2 17C6 U3 CY6212BV_2 18C7 U4 DS2174 12C7 U5 XC25_FG256 13C6 14C5 15C5 U6 DS26334_U 285 383 387 3D3 3D7 4B3 4B7 4D3 4D7 5B3 5B7 5D3 5D7 6B3 6B7 6D3 6D7 U7 DS232 18A7 U8 NC7SZ86_U 11D2 U9 MAX1793_U 21D7 U10 CY6212BV_2 18C3 U11 NC7SZ86_U 11D2 U12 XC18V02V044C 12D3 U13 74_04_U 11A7 11B7 11B8 13A3 17A6 22A2 U14 74_04_U 11C7 11C8 11D7 11D8	U15 MAX1792_1 21D3 U16 XCFS_V020 13B2 U17 74_00 11B4 17A6 22B2 U18 74_04_U 11B7 11B8 11B8 11C7 11C7 11C8 U19 MAX6816_2 12B2 U20 MAX1793_U 21D5 X1 XTAL_U 16C7 X2 XTAL 17A4 Y1 OSC2 11B2 Y2 OSC2 11C2							
C									
B									
A									
	8	7	6	5	4	3	2	1	
						TITLE:	DATE:		
						ENGINEER:	PAGE:		