

MAX481/MAX483/MAX485/ MAX487–MAX491/MAX1487

Low-Power, Slew-Rate-Limited RS-485/RS-422 Transceivers

General Description

The MAX481, MAX483, MAX485, MAX487–MAX491, and MAX1487 are low-power transceivers for RS-485 and RS-422 communication. Each part contains one driver and one receiver.

Applications

- Low-Power RS-485 Transceivers
- Low-Power RS-422 Transceivers
- Level Translators
- Transceivers for EMI-Sensitive Applications
- Industrial-Control Local Area Networks

Benefits and Features

- Low Power Consumption Minimizes Thermal Dissipation, Reducing System Cost
 - 120 μ A to 500 μ A Quiescent Current
 - Shutdown Current of 0.1 μ A
 - Single 5V Supply Voltage
- Slew-Rate-Limited Drivers (MAX483/MAX487/MAX488 and MAX489)
 - Up to 250kbps Data Rate
 - Unlimited Drivers: Up to 2.5Mbps Data Rate
- Integrated Protection Enhances System Robustness
 - Short Circuit Current Limited Driver
 - Integrated Thermal Shutdown
 - Receiver Fail-Safe for Input Open Circuit Guarantees Logic High
- 1/4 Unit Loading (MAX487/ MAX1487 only) Allows Up to 128 Devices on a Single Bus
 - 48k Ω Receiver Input Resistance

Ordering Information appears at end of data sheet.

Selection Table

PART NUMBER	HALF/FULL DUPLEX	DATA RATE (Mbps)	SLEW-RATE LIMITED	LOW-POWER SHUTDOWN	RECEIVER/ DRIVER ENABLE	QUIESCENT CURRENT (μ A)	NUMBER OF RECEIVERS ON BUS	PIN COUNT
MAX481	Half	2.5	No	Yes	Yes	300	32	8
MAX483	Half	0.25	Yes	Yes	Yes	120	32	8
MAX485	Half	2.5	No	No	Yes	300	32	8
MAX487	Half	0.25	Yes	Yes	Yes	120	128	8
MAX488	Full	0.25	Yes	No	No	120	32	8
MAX489	Full	0.25	Yes	No	Yes	120	32	14
MAX490	Full	2.5	No	No	No	300	32	8
MAX491	Full	2.5	No	No	Yes	300	32	14
MAX1487	Half	2.5	No	No	Yes	230	128	8

Absolute Maximum Ratings

Supply Voltage (V_{CC}).....	12V	14-Pin SO (derate 8.33mW/°C above +70°C).....	667mW
Control Input Voltage (\overline{RE} , DE).....	-0.5V to ($V_{CC} + 0.5V$)	8-Pin μ MAX (derate 4.1mW/°C above +70°C).....	830mW
Driver Input Voltage (DI).....	-0.5V to ($V_{CC} + 0.5V$)	8-Pin Cerdip (derate 8.00mW/°C above +70°C).....	640mW
Driver Output Voltage (A, B).....	-8V to +12.5V	14-Pin Cerdip (derate 9.09mW/°C above +70°C).....	727mW
Receiver Input Voltage (A, B).....	-8V to +12.5V	Operating Temperature Ranges	
Receiver Output Voltage (RO).....	-0.5V to ($V_{CC} + 0.5V$)	MAX4__C_/MAX1487C_A.....	0°C to +70°C
Continuous Power Dissipation ($T_A = +70^\circ\text{C}$)		MAX4__E_/MAX1487E_A.....	-40°C to +85°C
8-Pin Plastic DIP (derate 9.09mW/°C above +70°C) ..	727mW	MAX4__MJ_/MAX1487MJA.....	-55°C to +125°C
14-Pin Plastic DIP (derate 10.00mW/°C above +70°C) ..	800mW	Storage Temperature Range.....	
8-Pin SO (derate 5.88mW/°C above +70°C).....	471mW	-65°C to +160°C	
		Lead Temperature (soldering, 10sec).....	
		+300°C	

Stresses beyond those listed under "Absolute Maximum Ratings" may cause permanent damage to the device. These are stress ratings only, and functional operation of the device at these or any other conditions beyond those indicated in the operational sections of the specifications is not implied. Exposure to absolute maximum rating conditions for extended periods may affect device reliability.

DC Electrical Characteristics

($V_{CC} = 5V \pm 5\%$, $T_A = T_{MIN}$ to T_{MAX} , unless otherwise noted.) (Notes 1, 2)

PARAMETER	SYMBOL	CONDITIONS	MIN	TYP	MAX	UNITS
Differential Driver Output (no load)	V_{OD1}				5	V
Differential Driver Output (with load)	V_{OD2}	R = 50 Ω (RS-422)	2			V
		R = 27 Ω (RS-485), Figure 4	1.5		5	V
Change in Magnitude of Driver Differential Output Voltage for Complementary Output States	ΔV_{OD}	R = 27 Ω or 50 Ω , Figure 4			0.2	V
Driver Common-Mode Output Voltage	V_{OC}	R = 27 Ω or 50 Ω , Figure 4			3	V
Change in Magnitude of Driver Common-Mode Output Voltage for Complementary Output States	ΔV_{OD}	R = 27 Ω or 50 Ω , Figure 4			0.2	V
Input High Voltage	V_{IH}	DE, DI, \overline{RE}	2.0			V
Input Low Voltage	V_{IL}	DE, DI, \overline{RE}			0.8	V
Input Current	I_{IN1}	DE, DI, \overline{RE}			± 2	μ A
Input Current (A, B)	I_{IN2}	DE = 0V; $V_{CC} = 0V$ or 5.25V, all devices except MAX487/MAX1487	$V_{IN} = 12V$		1.0	mA
			$V_{IN} = -7V$		-0.8	
	MAX487/MAX1487, DE = 0V, $V_{CC} = 0V$ or 5.25V	$V_{IN} = 12V$		0.25	mA	
		$V_{IN} = -7V$		-0.2		
Receiver Differential Threshold Voltage	V_{TH}	$-7V \leq V_{CM} \leq 12V$	-0.2		0.2	V
Receiver Input Hysteresis	ΔV_{TH}	$V_{CM} = 0V$		70		mV
Receiver Output High Voltage	V_{OH}	$I_O = -4mA$, $V_{ID} = 200mV$	3.5			V
Receiver Output Low Voltage	V_{OL}	$I_O = 4mA$, $V_{ID} = -200mV$			0.4	V
Three-State (high impedance) Output Current at Receiver	I_{OZR}	$0.4V \leq V_O \leq 2.4V$			± 1	μ A
Receiver Input Resistance	R_{IN}	$-7V \leq V_{CM} \leq 12V$, all devices except MAX487/MAX1487	12			k Ω
		$-7V \leq V_{CM} \leq 12V$, MAX487/MAX1487	48			k Ω

DC Electrical Characteristics (continued)

($V_{CC} = 5V \pm 5\%$, $T_A = T_{MIN}$ to T_{MAX} , unless otherwise noted.) (Notes 1, 2)

PARAMETER	SYMBOL	CONDITIONS	MIN	TYP	MAX	UNITS
No-Load Supply Current (Note 3)	I_{CC}	MAX488/MAX489, DE, DI, $\overline{RE} = 0V$ or V_{CC}		120	250	μA
		MAX490/MAX491, DE, DI, $\overline{RE} = 0V$ or V_{CC}		300	500	
		MAX481/MAX485, $\overline{RE} = 0V$ or V_{CC}	DE = V_{CC}	500	900	
			DE = 0V	300	500	
		MAX1487, $\overline{RE} = 0V$ or V_{CC}	DE = V_{CC}	300	500	
			DE = 0V	230	400	
MAX483/MAX487, $\overline{RE} = 0V$ or V_{CC}	DE = 5V	MAX483 MAX487	350	650		
	DE = 0V		250	400		
Supply Current in Shutdown	I_{SHDN}	MAX481/483/487, DE = 0V, $\overline{RE} = V_{CC}$		0.1	10	μA
Driver Short-Circuit Current, $V_O = \text{High}$	I_{OSD1}	$-7V \leq V_O \leq 12V$ (Note 4)	35		250	mA
Driver Short-Circuit Current, $V_O = \text{Low}$	I_{OSD2}	$-7V \leq V_O \leq 12V$ (Note 4)	35		250	mA
Receiver Short-Circuit Current	I_{OSR}	$0V \leq V_O \leq V_{CC}$	7		95	mA

Switching Characteristics—MAX481/MAX485, MAX490/MAX491, MAX1487

($V_{CC} = 5V \pm 5\%$, $T_A = T_{MIN}$ to T_{MAX} , unless otherwise noted.) (Notes 1, 2)

PARAMETER	SYMBOL	CONDITIONS	MIN	TYP	MAX	UNITS	
Driver Input to Output	t_{PLH}	Figures 6 and 8, $R_{DIFF} = 54\Omega$, $C_{L1} = C_{L2} = 100pF$	10	30	60	ns	
	t_{PHL}		10	30	60		
Driver Output Skew to Output	t_{SKEW}	Figures 6 and 8, $R_{DIFF} = 54\Omega$, $C_{L1} = C_{L2} = 100pF$		5	10	ns	
Driver Rise or Fall Time	t_R, t_F	Figures 6 and 8, $R_{DIFF} = 54\Omega$, $C_{L1} = 100pF$, $C_{L2} = 100pF$	MAX481, MAX485, MAX1487	3	15	40	ns
			MAX490C/E, MAX491C/E	5	15	25	
			MAX490M, MAX491M	3	15	40	
Driver Enable to Output High	t_{ZH}	Figures 7 and 9, $C_L = 100pF$, S2 closed		40	70	ns	
Driver Enable to Output Low	t_{ZL}	Figures 7 and 9, $C_L = 100pF$, S1 closed		40	70	ns	
Driver Disable Time from Low	t_{LZ}	Figures 7 and 9, $C_L = 15pF$, S1 closed		40	70	ns	
Driver Disable Time from High	t_{HZ}	Figures 7 and 9, $C_L = 15pF$, S2 closed		40	70	ns	
Receiver Input to Output	t_{PLH}, t_{PHL}	Figures 6 and 10, $R_{DIFF} = 54\Omega$, $C_{L1} = 100pF$, $C_{L2} = 100pF$	MAX481, MAX485, MAX1487	20	90	200	ns
			MAX490C/E, MAX491C/E	20	90	150	
			MAX490M, MAX491M	20	90	200	
$ t_{PLH} - t_{PHL} $ Differential Receiver Skew	t_{SKD}	Figures 6 and 10, $R_{DIFF} = 54\Omega$, $C_{L1} = C_{L2} = 100pF$		13		ns	
Receiver Enable to Output Low	t_{ZL}	Figures 5 and 11, $C_{RL} = 15pF$, S1 closed		20	50	ns	
Receiver Enable to Output High	t_{ZH}	Figures 5 and 11, $C_{RL} = 15pF$, S2 closed		20	50	ns	
Receiver Disable Time from Low	t_{LZ}	Figures 5 and 11, $C_{RL} = 15pF$, S1 closed		20	50	ns	
Receiver Disable Time from High	t_{HZ}	Figures 5 and 11, $C_{RL} = 15pF$, S2 closed		20	50	ns	
Maximum Data Rate	f_{MAX}		2.5			Mbps	
Time to Shutdown	t_{SHDN}	MAX481 (Note 5)	50	200	600	ns	

Switching Characteristics—MAX481/MAX485, MAX490/MAX491, MAX1487 (continued)

($V_{CC} = 5V \pm 5\%$, $T_A = T_{MIN}$ to T_{MAX} , unless otherwise noted.) (Notes 1, 2)

PARAMETER	SYMBOL	CONDITIONS	MIN	TYP	MAX	UNITS
Driver Enable from Shutdown to Output High (MAX481)	$t_{ZH(SHDN)}$	Figures 7 and 9, $C_L = 100\text{pF}$, S2 closed		40	100	ns
Driver Enable from Shutdown to Output Low (MAX481)	$t_{ZL(SHDN)}$	Figures 7 and 9, $C_L = 100\text{pF}$, S1 closed		40	100	ns
Receiver Enable from Shutdown to Output High (MAX481)	$t_{ZH(SHDN)}$	Figures 5 and 11, $C_L = 15\text{pF}$, S2 closed, A - B = 2V		300	1000	ns
Receiver Enable from Shutdown to Output Low (MAX481)	$t_{ZL(SHDN)}$	Figures 5 and 11, $C_L = 15\text{pF}$, S1 closed, B - A = 2V		300	1000	ns

Switching Characteristics—MAX483, MAX487/MAX488/MAX489

($V_{CC} = 5V \pm 5\%$, $T_A = T_{MIN}$ to T_{MAX} , unless otherwise noted.) (Notes 1, 2)

PARAMETER	SYMBOL	CONDITIONS	MIN	TYP	MAX	UNITS
Driver Input to Output	t_{PLH}	Figures 6 and 8, $R_{DIFF} = 54\Omega$, $C_{L1} = C_{L2} = 100\text{pF}$	250	800	2000	ns
	t_{PHL}		250	800	2000	
Driver Output Skew to Output	t_{SKEW}	Figures 6 and 8, $R_{DIFF} = 54\Omega$, $C_{L1} = C_{L2} = 100\text{pF}$		100	800	ns
Driver Rise or Fall Time	t_R, t_F	Figures 6 and 8, $R_{DIFF} = 54\Omega$, $C_{L1} = C_{L2} = 100\text{pF}$	250		2000	ns
Driver Enable to Output High	t_{ZH}	Figures 7 and 9, $C_L = 100\text{pF}$, S2 closed	250		2000	ns
Driver Enable to Output Low	t_{ZL}	Figures 7 and 9, $C_L = 100\text{pF}$, S1 closed	250		2000	ns
Driver Disable Time from Low	t_{LZ}	Figures 7 and 9, $C_L = 15\text{pF}$, S1 closed	300		3000	ns
Driver Disable Time from High	t_{HZ}	Figures 7 and 9, $C_L = 15\text{pF}$, S2 closed	300		3000	ns
Receiver Input to Output	t_{PLH}	Figures 6 and 10, $R_{DIFF} = 54\Omega$, $C_{L1} = C_{L2} = 100\text{pF}$	250		2000	ns
	t_{PHL}		250		2000	
$t_{PLH} - t_{PHL}$ Differential Receiver Skew	t_{SKD}	Figures 6 and 10, $R_{DIFF} = 54\Omega$, $C_{L1} = C_{L2} = 100\text{pF}$		100		ns
Receiver Enable to Output Low	t_{ZL}	Figures 5 and 11, $C_{RL} = 15\text{pF}$, S1 closed		20	50	ns
Receiver Enable to Output High	t_{ZH}	Figures 5 and 11, $C_{RL} = 15\text{pF}$, S2 closed		20	50	ns
Receiver Disable Time from Low	t_{LZ}	Figures 5 and 11, $C_{RL} = 15\text{pF}$, S1 closed		20	50	ns
Receiver Disable Time from High	t_{HZ}	Figures 5 and 11, $C_{RL} = 15\text{pF}$, S2 closed		20	50	ns
Maximum Data Rate	f_{MAX}	$t_{PLH}, t_{PHL} < 50\%$ of data period	250			kbps
Time to Shutdown	t_{SHDN}	MAX483/MAX487 (Note 5)	50	200	600	ns
Driver Enable from Shutdown to Output High	$t_{ZH(SHDN)}$	MAX483/MAX487, Figures 7 and 9, $C_L = 100\text{pF}$, S2 closed			2000	ns
Driver Enable from Shutdown to Output Low	$t_{ZL(SHDN)}$	MAX483/MAX487, Figures 7 and 9, $C_L = 100\text{pF}$, S1 closed			2000	ns
Receiver Enable from Shutdown to Output High	$t_{ZH(SHDN)}$	MAX483/MAX487, Figures 5 and 11, $C_L = 15\text{pF}$, S2 closed			2500	ns
Receiver Enable from Shutdown to Output Low	$t_{ZL(SHDN)}$	MAX483/MAX487, Figures 5 and 11, $C_L = 15\text{pF}$, S1 closed			2500	ns

Notes for Electrical/Switching Characteristics—MAX481/MAX485, MAX490/ MAX491, MAX1487

($V_{CC} = 5V \pm 5\%$, $T_A = T_{MIN}$ to T_{MAX} , unless otherwise noted.) (Notes 1, 2)

Note 1: All currents into device pins are positive; all currents out of device pins are negative. All voltages are referenced to device ground unless otherwise specified.

Note 2: All typical specifications are given for $V_{CC} = 5V$ and $T_A = +25^\circ C$.

Note 3: Supply current specification is valid for loaded transmitters when $DE = 0V$.

Note 4: Applies to peak current. See *Typical Operating Characteristics*.

Note 5: The MAX481/MAX483/MAX487 are put into shutdown by bringing \overline{RE} high and DE low. If the inputs are in this state for less than 50ns, the parts are guaranteed not to enter shutdown. If the inputs are in this state for at least 600ns, the parts are guaranteed to have entered shutdown. See *Low-Power Shutdown Mode* section.

Typical Operating Characteristics

($V_{CC} = 5V$, $T_A = +25^\circ C$, unless otherwise noted.)

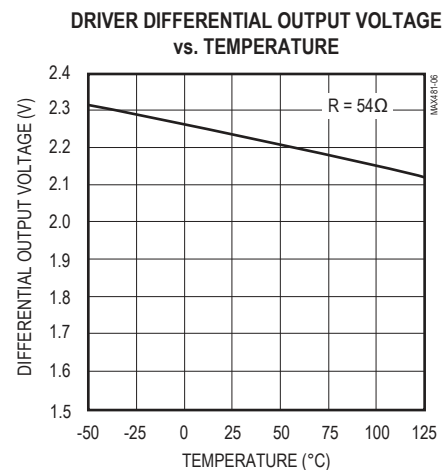
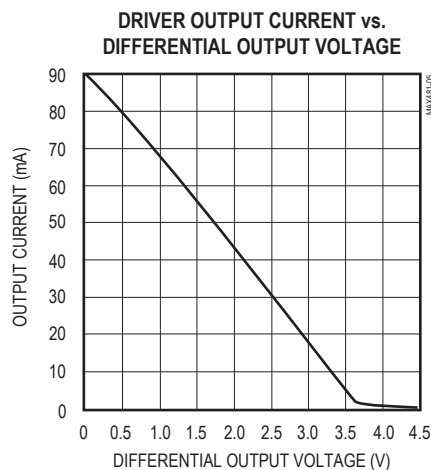
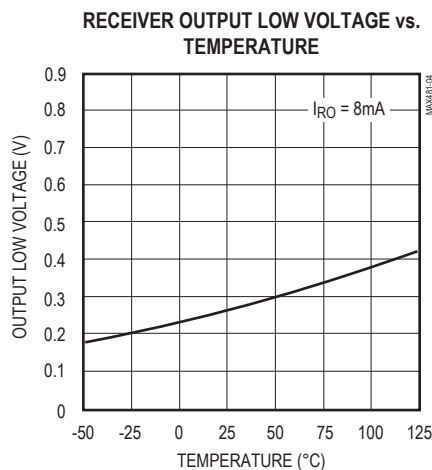
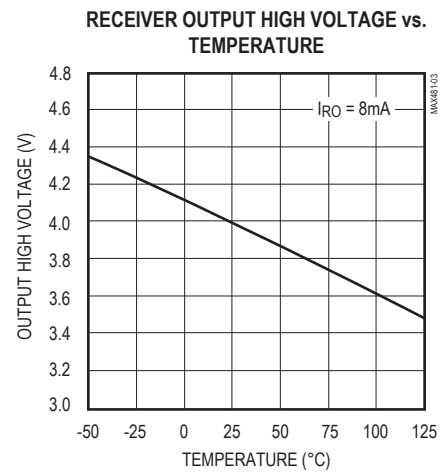
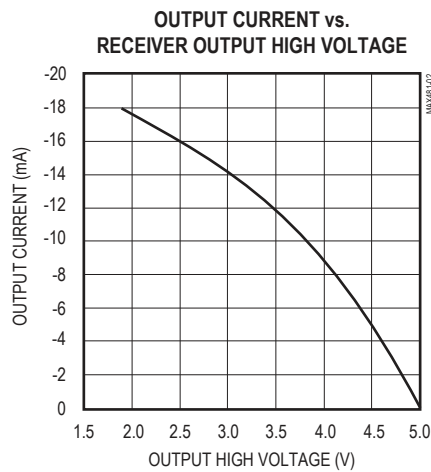
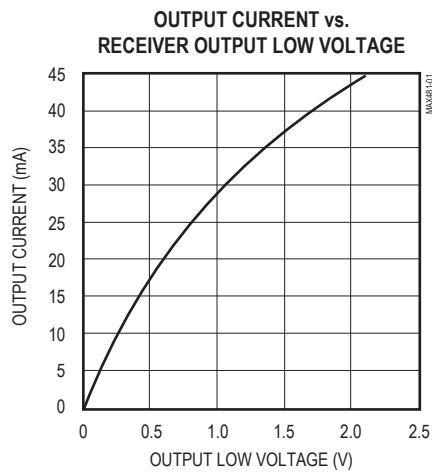

Typical Operating Characteristics (continued)

($V_{CC} = 5V$, $T_A = +25^\circ C$, unless otherwise noted.)

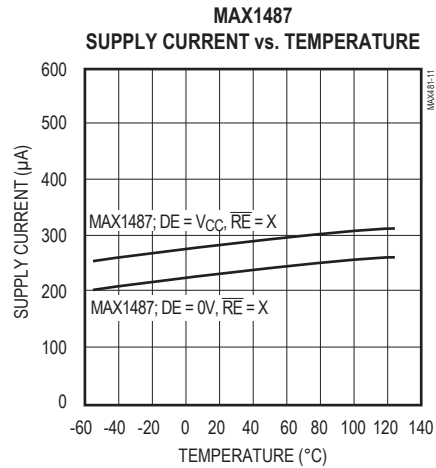
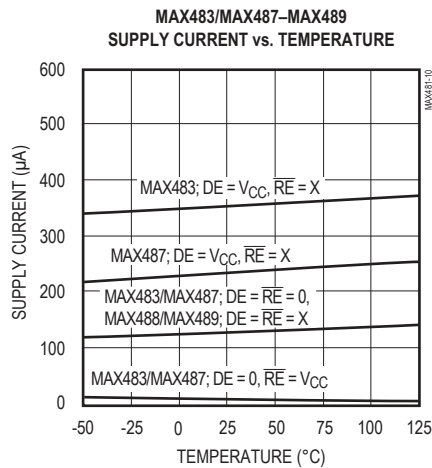
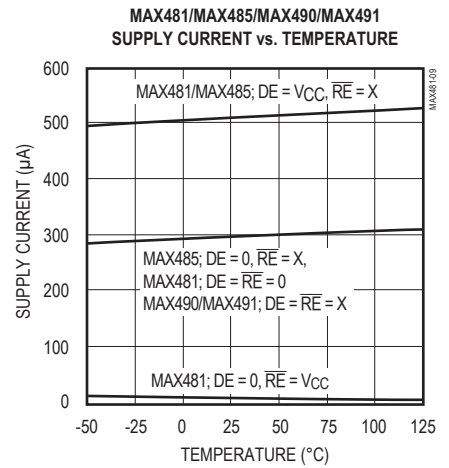
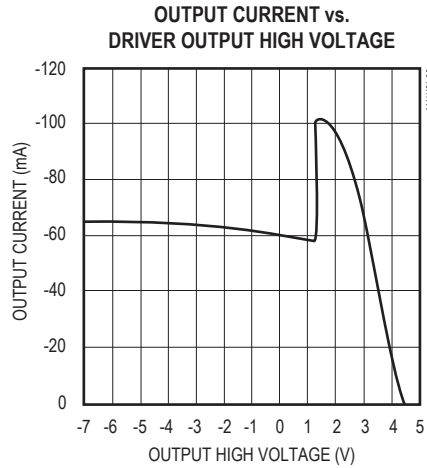
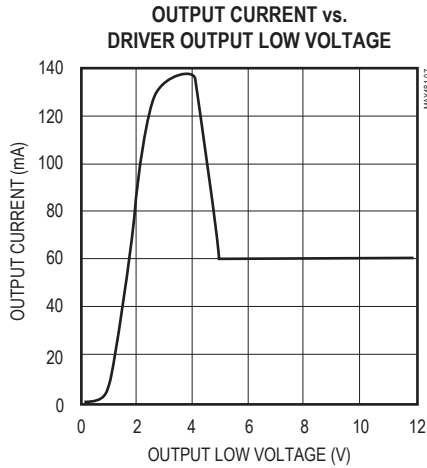

Pin Description

PIN					NAME	FUNCTION
MAX481/MAX483/ MAX485/MAX487/ MAX1487		MAX488/ MAX490		MAX489/ MAX491		
DIP/SO	μMAX	DIP/SO	μMAX	DIP/SO		
1	3	2	4	2	RO	Receiver Output: If A > B by 200mV, RO will be high; If A < B by 200mV, RO will be low.
2	4	—	—	3	\overline{RE}	Receiver Output Enable. RO is enabled when \overline{RE} is low; RO is high impedance when RE is high.
3	5	—	—	4	DE	Driver Output Enable. The driver outputs, Y and Z, are enabled by bringing DE high. They are high impedance when DE is low. If the driver outputs are enabled, the parts function as line drivers. While they are high impedance, they function as line receivers if \overline{RE} is low.
4	6	3	5	5	DI	Driver Input. A low on DI forces output Y low and output Z high. Similarly, a high on DI forces output Y high and output Z low.
5	7	4	6	6,7	GND	Ground
—	—	5	7	9	Y	Noninverting Driver Output
—	—	6	8	10	Z	Inverting Driver Output
6	8	—	—	—	A	Noninverting Receiver Input and Noninverting Driver Output
—	—	8	2	12	A	Noninverting Receiver Input
7	1	—	—	—	B	Inverting Receiver Input and Inverting Driver Output
—	—	7	1	11	B	Inverting Receiver Input
8	2	1	3	14	V _{CC}	Positive Supply: 4.75V ≤ V _{CC} ≤ 5.25V
—	—	—	—	1, 8, 13	N.C.	No Connect—not internally connected

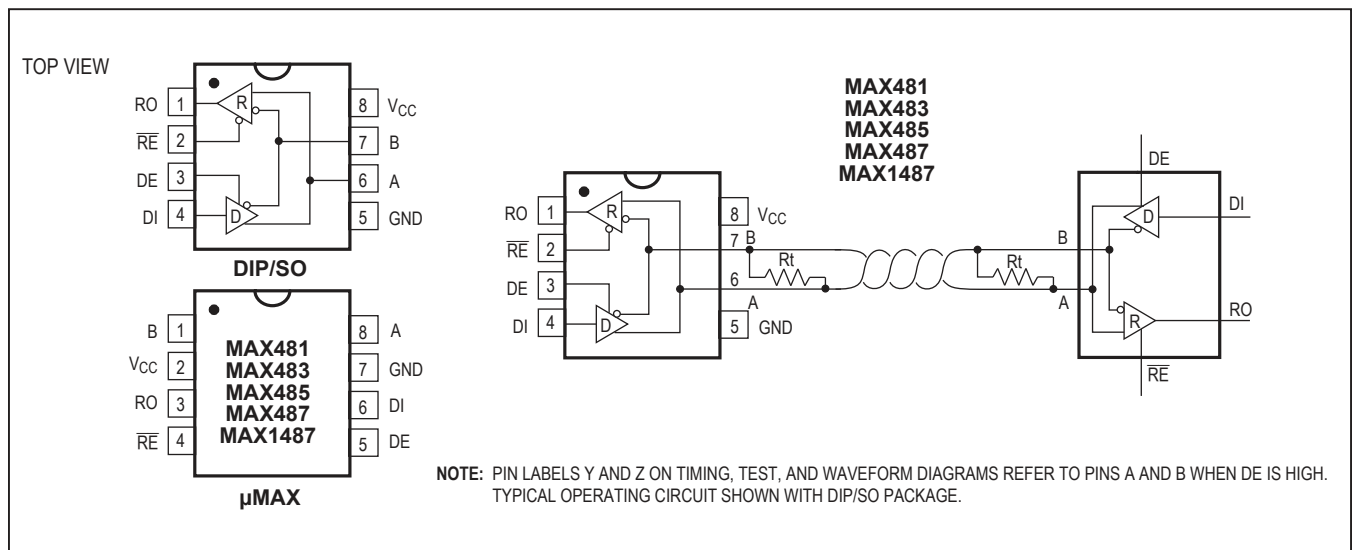

Figure 1. MAX481/MAX483/MAX485/MAX487/MAX1487 Pin Configuration and Typical Operating Circuit

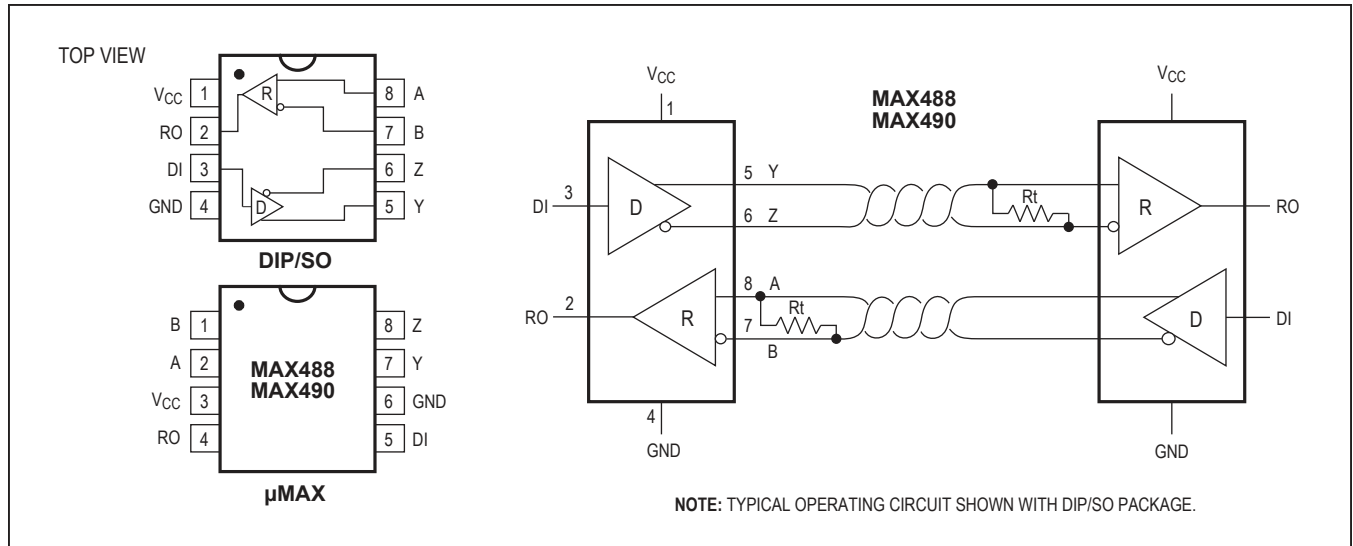

Figure 2. MAX488/MAX490 Pin Configuration and Typical Operating Circuit

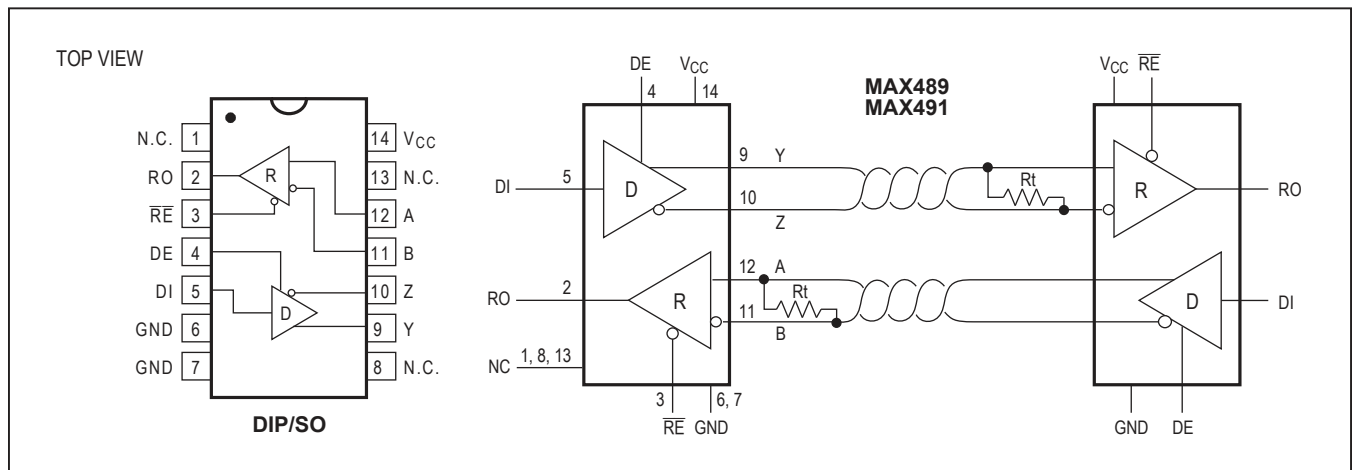

Figure 3. MAX489/MAX491 Pin Configuration and Typical Operating Circuit

Applications Information

The MAX481/MAX483/MAX485/MAX487–MAX491 and MAX1487 are low-power transceivers for RS-485 and RS-422 communications. The MAX481, MAX485, MAX490, MAX491, and MAX1487 can transmit and receive at data rates up to 2.5Mbps, while the MAX483, MAX487, MAX488, and MAX489 are specified for data rates up to 250kbps. The MAX488–MAX491 are full-duplex transceivers while the MAX481, MAX483, MAX485, MAX487, and MAX1487 are half-duplex. In addition, Driver Enable (DE) and Receiver Enable (\overline{RE}) pins are included on the MAX481, MAX483, MAX485, MAX487, MAX489, MAX491, and MAX1487. When disabled, the driver and receiver outputs are high impedance.

MAX487/MAX1487: 128 Transceivers on the Bus

The 48k Ω , $1/4$ -unit-load receiver input impedance of the MAX487 and MAX1487 allows up to 128 transceivers on a bus, compared to the 1-unit load (12k Ω input impedance) of standard RS-485 drivers (32 transceivers maximum). Any combination of MAX487/MAX1487 and other RS-485 transceivers with a total of 32 unit loads or less can be put on the bus. The MAX481/MAX483/MAX485 and MAX488–MAX491 have standard 12k Ω Receiver Input impedance.

Test Circuits

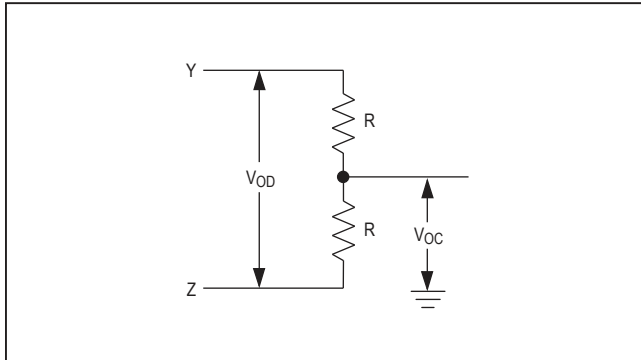

Figure 4. Driver DC Test Load

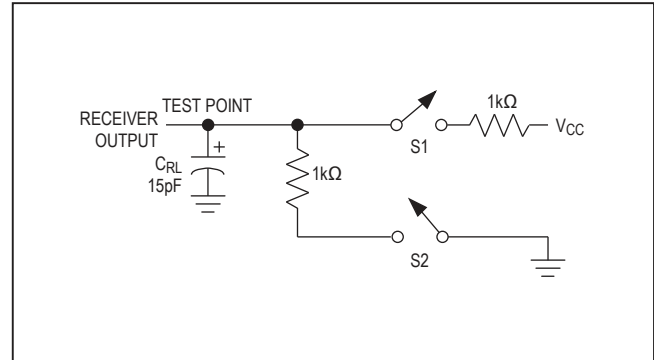

Figure 5. Receiver Timing Test Load

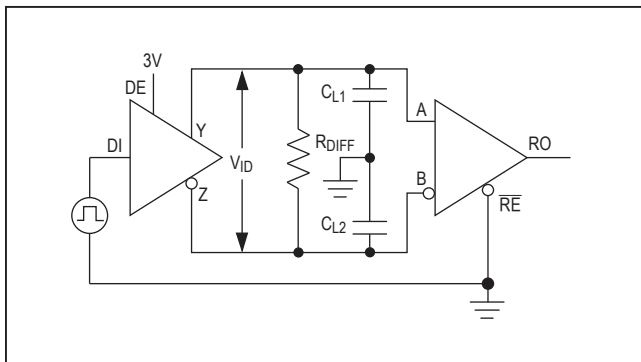

Figure 6. Driver/Receiver Timing Test Circuit

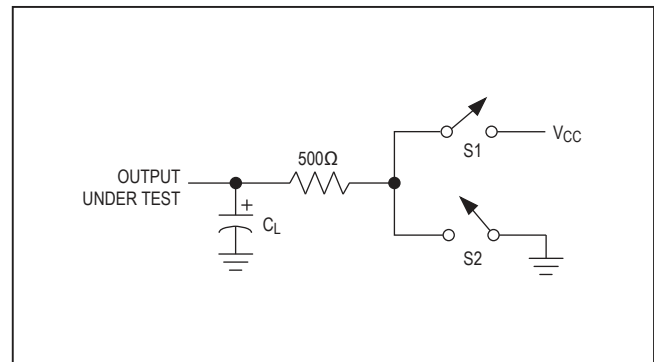

Figure 7. Driver Timing Test Load

**MAX483/MAX487/MAX488/MAX489:
Reduced EMI and Reflections**

The MAX483 and MAX487–MAX489 are slew-rate limited, minimizing EMI and reducing reflections caused by improperly terminated cables. Figure 12 shows the driver output waveform and its Fourier analysis of a 150kHz signal transmitted by a MAX481, MAX485, MAX490,

MAX491, or MAX1487. High-frequency harmonics with large amplitudes are evident. Figure 13 shows the same information displayed for a MAX483, MAX487, MAX488, or MAX489 transmitting under the same conditions. Figure 13's high-frequency harmonics have much lower amplitudes, and the potential for EMI is significantly reduced.

Switching Waveforms

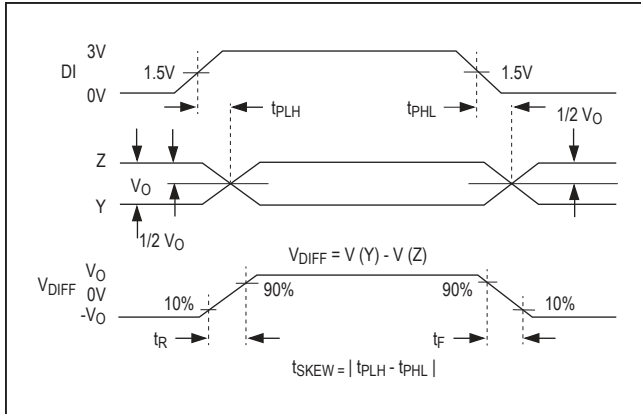

Figure 8. Driver Propagation Delays

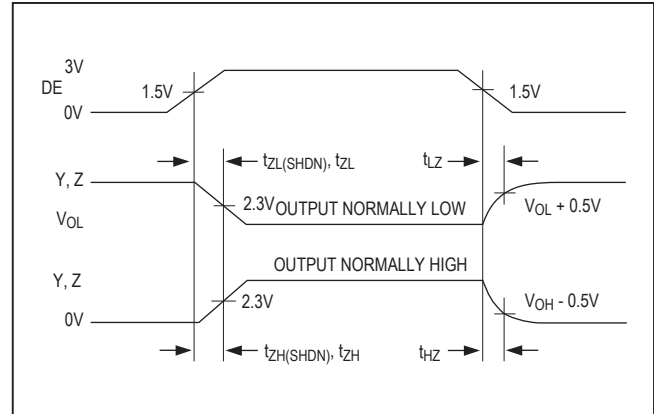

Figure 9. Driver Enable and Disable Times (except MAX488 and MAX490)

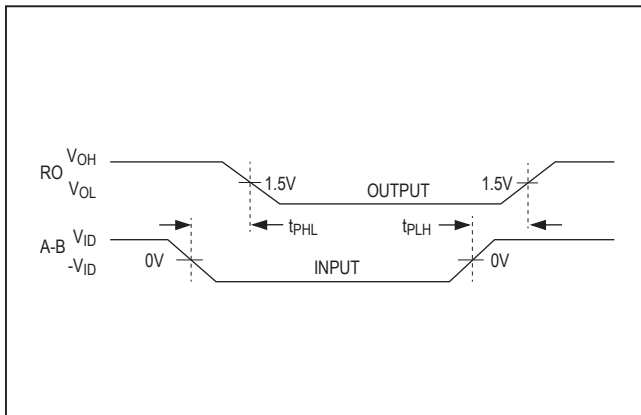

Figure 10. Receiver Propagation Delays

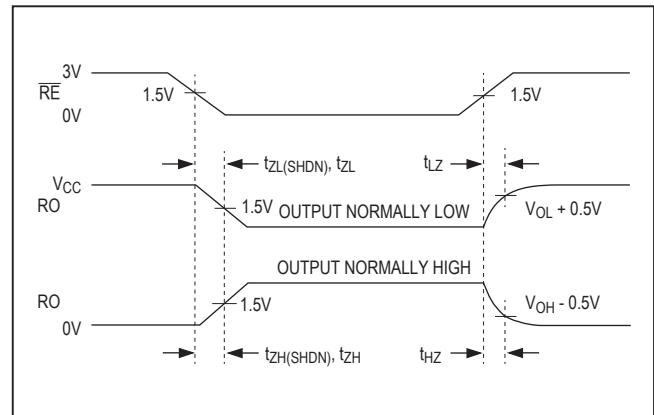

Figure 11. Receiver Enable and Disable Times (except MAX488 and MAX490)

Function Tables (MAX481/MAX483/MAX485/MAX487/MAX1487)

Table 1. Transmitting

INPUTS			OUTPUTS	
RE	DE	DI	Z	Y
X	1	1	0	1
X	1	0	1	0
0	0	X	High-Z	High-Z
1	0	X	High-Z*	High-Z*

X = Don't care

High-Z = High impedance

* Shutdown mode for MAX481/MAX483/MAX487

Table 2. Receiving

INPUTS			OUTPUT
RE	DE	A-B	RO
0	0	> +0.2V	1
0	0	< -0.2V	0
0	0	Inputs open	1
1	0	X	High-Z*
0	0	Shorted	Indeterminate

X = Don't care

High-Z = High impedance

* Shutdown mode for MAX481/MAX483/MAX487

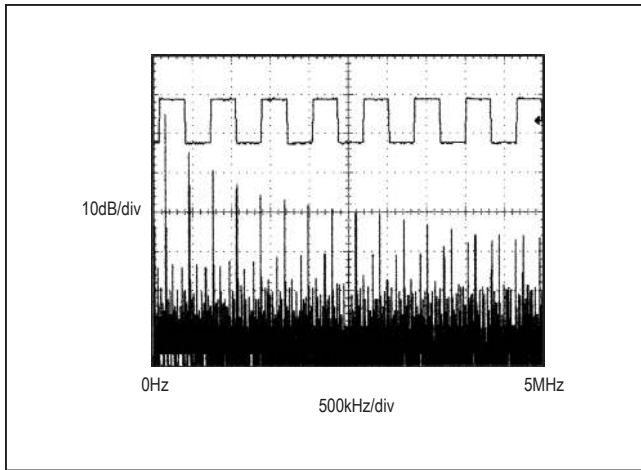

Figure 12. Driver Output Waveform and FFT Plot of MAX481/MAX485/MAX490/MAX491/MAX1487 Transmitting a 150kHz Signal

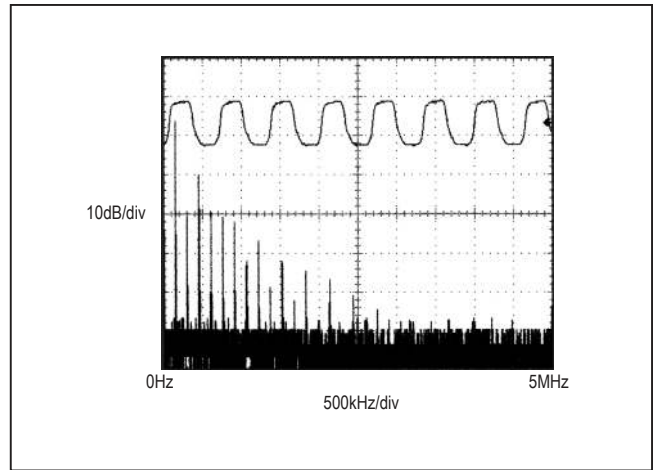

Figure 13. Driver Output Waveform and FFT Plot of MAX483/MAX487–MAX489 Transmitting a 150kHz Signal

Low-Power Shutdown Mode (MAX481/MAX483/MAX487)

A low-power shutdown mode is initiated by bringing both \overline{RE} high and DE low. The devices will not shut down unless both the driver and receiver are disabled. In shutdown, the devices typically draw only 0.1 μ A of supply current.

\overline{RE} and DE may be driven simultaneously; the parts are guaranteed not to enter shutdown if \overline{RE} is high and DE is low for less than 50ns. If the inputs are in this state for at least 600ns, the parts are guaranteed to enter shutdown.

For the MAX481, MAX483, and MAX487, the t_{ZH} and t_{ZL} enable times assume the part was not in the lowpower shutdown state (the MAX485/MAX488–MAX491 and MAX1487 can not be shut down). The $t_{ZH}(SHDN)$ and $t_{ZL}(SHDN)$ enable times assume the parts were shut down (see *Electrical Characteristics*).

It takes the drivers and receivers longer to become enabled from the low-power shutdown state ($t_{ZH}(SHDN)$, $t_{ZL}(SHDN)$) than from the operating mode (t_{ZH} , t_{ZL}). (The parts are in operating mode if the \overline{RE} , DE inputs equal a logical 0,1 or 1,1 or 0, 0.)

Driver Output Protection

Excessive output current and power dissipation caused by faults or by bus contention are prevented by two mechanisms. A foldback current limit on the output stage provides immediate protection against short circuits over the whole common-mode voltage range (see *Typical Operating Characteristics*). In addition, a thermal shutdown circuit forces the driver outputs into a high-impedance state if the die temperature rises excessively.

Propagation Delay

Many digital encoding schemes depend on the difference between the driver and receiver propagation delay times. Typical propagation delays are shown in Figures 15–18 using Figure 14's test circuit.

The difference in receiver delay times, $|t_{PLH} - t_{PHL}|$, is typically under 13ns for the MAX481, MAX485, MAX490, MAX491, and MAX1487 and is typically less than 100ns for the MAX483 and MAX487–MAX489.

The driver skew times are typically 5ns (10ns max) for the MAX481, MAX485, MAX490, MAX491, and MAX1487, and are typically 100ns (800ns max) for the MAX483 and MAX487–MAX489.

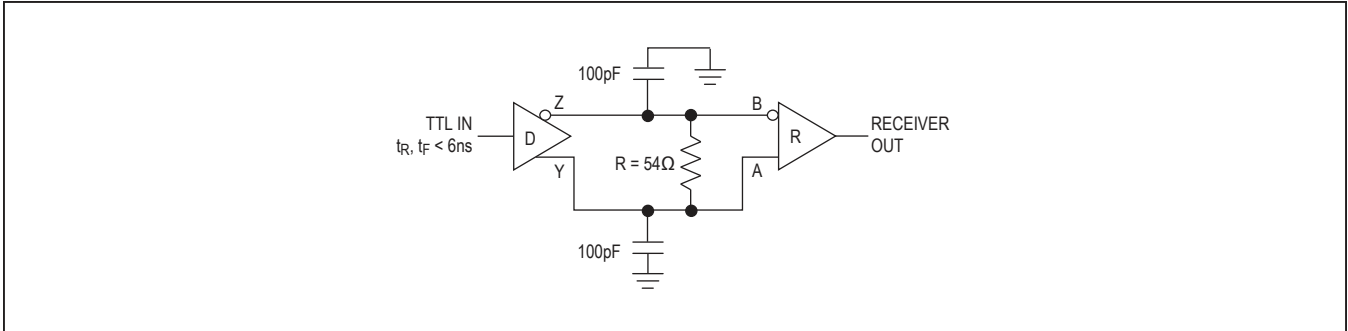

Figure 14. Receiver Propagation Delay Test Circuit

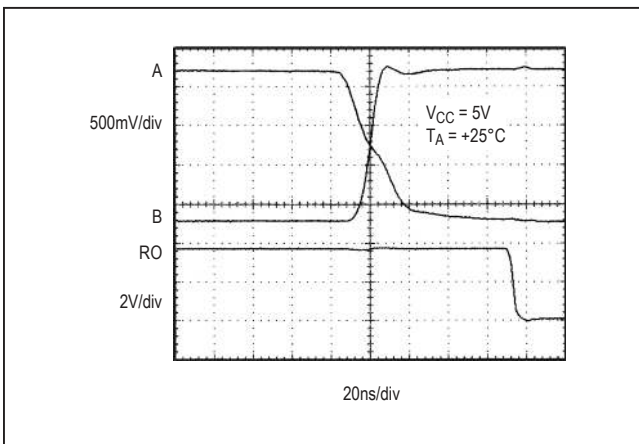

Figure 15. MAX481/MAX485/MAX490/MAX491/MAX1487 Receiver t_{PHL}

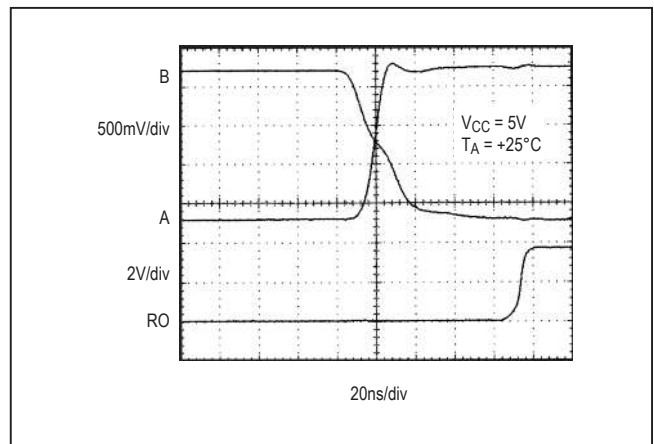

Figure 16. MAX481/MAX485/MAX490/MAX491/MAX1487 Receiver t_{PLH}

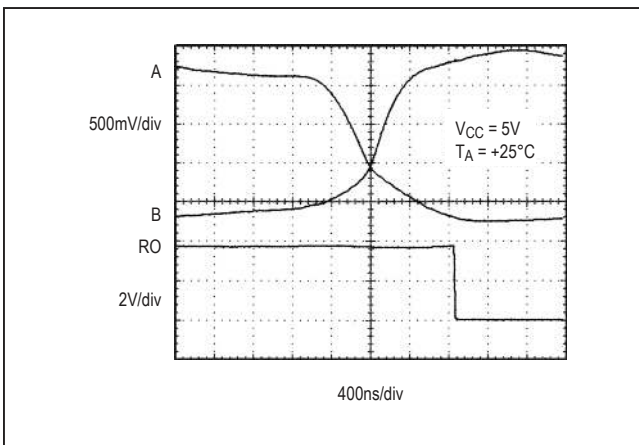

Figure 17. MAX483, MAX487-MAX489 Receiver t_{PHL}

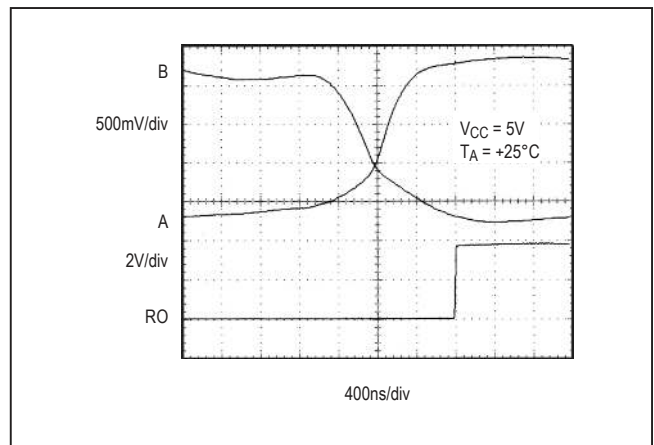

Figure 18. MAX483, MAX487-MAX489 Receiver t_{PLH}

Line Length vs. Data Rate

The RS-485/RS-422 standard covers line lengths up to 4000 feet. For line lengths greater than 4000 feet, see Figure 23.

Figures 19 and 20 show the system differential voltage for the parts driving 4000 feet of 26AWG twisted-pair wire at 110kHz into 120Ω loads.

Typical Applications

The MAX481, MAX483, MAX485, MAX487–MAX491, and MAX1487 transceivers are designed for bidirectional data communications on multipoint bus transmission lines.

Figures 21 and 22 show typical network applications circuits. These parts can also be used as line repeaters, with cable lengths longer than 4000 feet, as shown in Figure 23.

To minimize reflections, the line should be terminated at both ends in its characteristic impedance, and stub lengths off the main line should be kept as short as possible. The slew-rate-limited MAX483 and MAX487–MAX489 are more tolerant of imperfect termination.

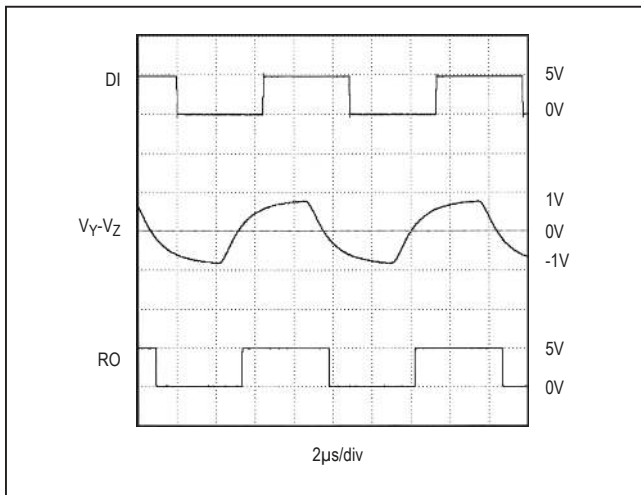

Figure 19. MAX481/MAX485/MAX490/MAX491/MAX1487 System Differential Voltage at 110kHz Driving 4000ft of Cable

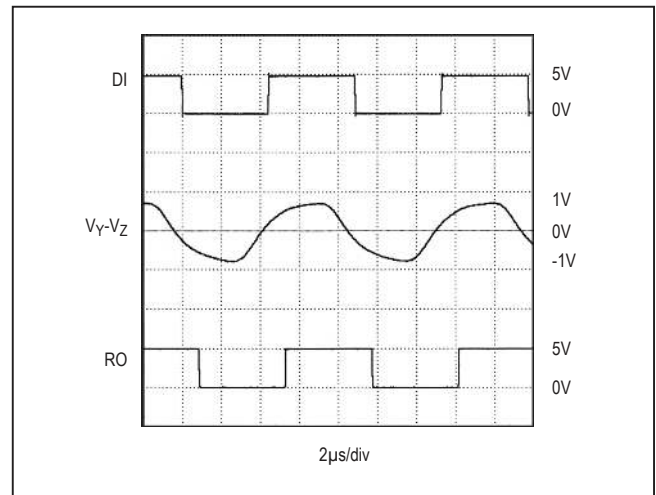

Figure 20. MAX483, MAX487–MAX489 System Differential Voltage at 110kHz Driving 4000ft of Cable

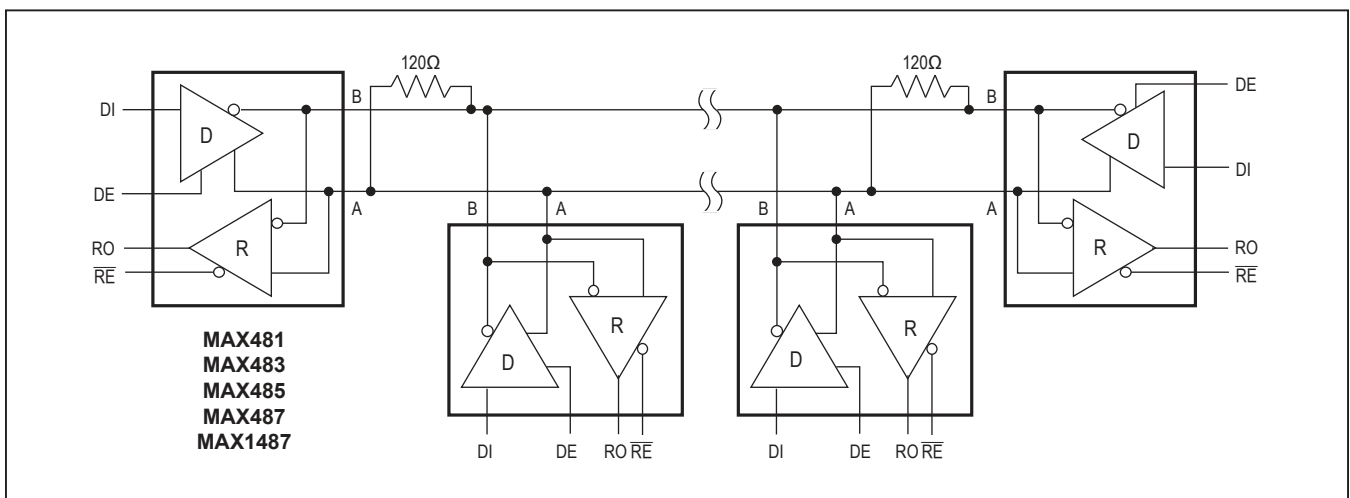

Figure 21. MAX481/MAX483/MAX485/MAX487/MAX1487 Typical Half-Duplex RS-485 Network

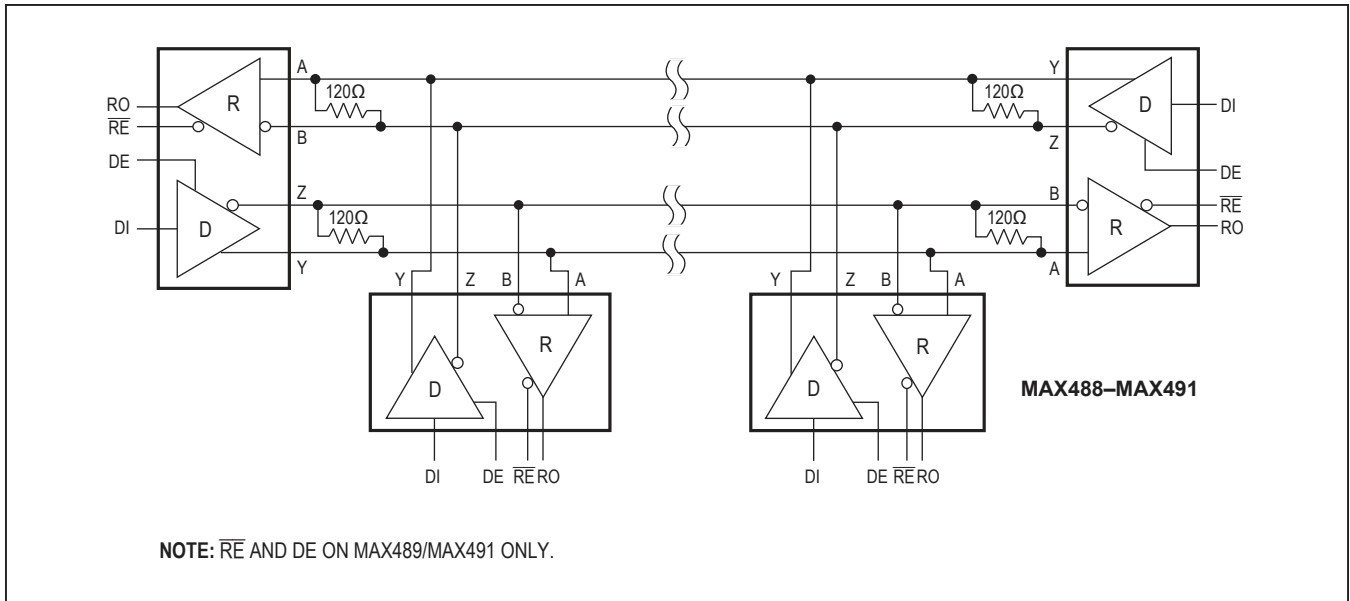

Figure 22. MAX488–MAX491 Full-Duplex RS-485 Network

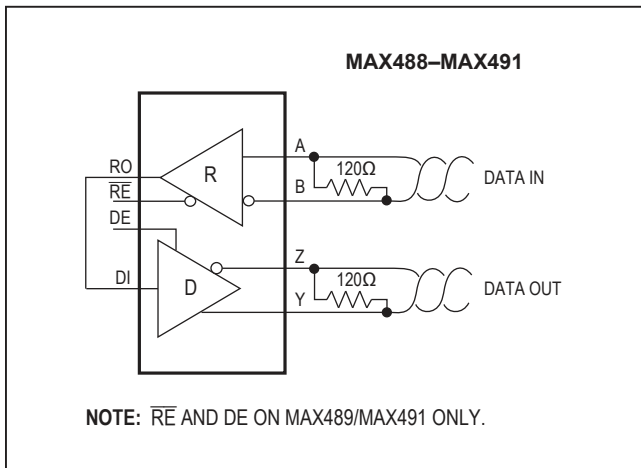

Figure 23. Line Repeater for MAX488–MAX491

Isolated RS-485

For isolated RS-485 applications, see the MAX253 and MAX1480 data sheets.

MAX481/MAX483/MAX485/
MAX487–MAX491/MAX1487

Low-Power, Slew-Rate-Limited
RS-485/RS-422 Transceivers

Ordering Information

PART	TEMP. RANGE	PIN-PACKAGE
MAX481 CPA	0°C to +70°C	8 Plastic DIP
MAX481CSA	0°C to +70°C	8 SO
MAX481CUA	0°C to +70°C	8 μ MAX
MAX481C/D	0°C to +70°C	Dice*
MAX481EPA	-40°C to +85°C	8 Plastic DIP
MAX481ESA	-40°C to +85°C	8 SO
MAX481MJA	-55°C to +125°C	8 CERDIP
MAX483 CPA	0°C to +70°C	8 Plastic DIP
MAX483CSA	0°C to +70°C	8 SO
MAX483CUA	0°C to +70°C	8 μ MAX
MAX483C/D	0°C to +70°C	Dice*
MAX483EPA	-40°C to +85°C	8 Plastic DIP
MAX483ESA	-40°C to +85°C	8 SO
MAX483MJA	-55°C to +125°C	8 CERDIP
MAX485 CPA	0°C to +70°C	8 Plastic DIP
MAX485CSA	0°C to +70°C	8 SO
MAX485CUA	0°C to +70°C	8 μ MAX
MAX485C/D	0°C to +70°C	Dice*
MAX485EPA	-40°C to +85°C	8 Plastic DIP
MAX485ESA	-40°C to +85°C	8 SO
MAX485MJA	-55°C to +125°C	8 CERDIP
MAX487 CPA	0°C to +70°C	8 Plastic DIP
MAX487CSA	0°C to +70°C	8 SO
MAX487CUA	0°C to +70°C	8 μ MAX
MAX487C/D	0°C to +70°C	Dice*
MAX487EPA	-40°C to +85°C	8 Plastic DIP
MAX487ESA	-40°C to +85°C	8 SO
MAX487MJA	-55°C to +125°C	8 CERDIP
MAX488 CPA	0°C to +70°C	8 Plastic DIP
MAX488CSA	0°C to +70°C	8 SO
MAX488CUA	0°C to +70°C	8 μ MAX
MAX488C/D	0°C to +70°C	Dice*
MAX488EPA	-40°C to +85°C	8 Plastic DIP
MAX488ESA	-40°C to +85°C	8 SO
MAX488MJA	-55°C to +125°C	8 CERDIP

PART	TEMP. RANGE	PIN-PACKAGE
MAX489 CPD	0°C to +70°C	14 Plastic DIP
MAX489CSD	0°C to +70°C	14 SO
MAX489C/D	0°C to +70°C	Dice*
MAX489EPD	-40°C to +85°C	14 Plastic DIP
MAX489ESD	-40°C to +85°C	14 SO
MAX489MJD	-55°C to +125°C	14 CERDIP
MAX490 CPA	0°C to +70°C	8 Plastic DIP
MAX490CSA	0°C to +70°C	8 SO
MAX490CUA	0°C to +70°C	8 μ MAX
MAX490C/D	0°C to +70°C	Dice*
MAX490EPA	-40°C to +85°C	8 Plastic DIP
MAX490ESA	-40°C to +85°C	8 SO
MAX490MJA	-55°C to +125°C	8 CERDIP
MAX491 CPD	0°C to +70°C	14 Plastic DIP
MAX491CSD	0°C to +70°C	14 SO
MAX491C/D	0°C to +70°C	Dice*
MAX491EPD	-40°C to +85°C	14 Plastic DIP
MAX491ESD	-40°C to +85°C	14 SO
MAX491MJD	-55°C to +125°C	14 CERDIP
MAX1487 CPA	0°C to +70°C	8 Plastic DIP
MAX1487CSA	0°C to +70°C	8 SO
MAX1487CUA	0°C to +70°C	8 μ MAX
MAX1487C/D	0°C to +70°C	Dice*
MAX1487EPA	-40°C to +85°C	8 Plastic DIP
MAX1487ESA	-40°C to +85°C	8 SO
MAX1487MJA	-55°C to +125°C	8 CERDIP

* Contact factory for dice specifications.

Package Information

For the latest package outline information and land patterns (footprints), go to www.maximintegrated.com/packages. Note that a “+”, “#”, or “-” in the package code indicates RoHS status only. Package drawings may show a different suffix character, but the drawing pertains to the package regardless of RoHS status.

PACKAGE TYPE	PACKAGE CODE	OUTLINE NO.	LAND PATTERN NO.
8 PDIP	P8-1	21-0043	—
8 SO	S8-2	21-0041	90-0096
8 μ MAX	U8-1	21-0036	90-0092
8 CERDIP	J8-2	21-0045	—
14 PDIP	P14-3	21-0043	—
14 SO	S14-1	21-0041	90-0112
14 CERDIP	J14-3	21-0045	—

Revision History

REVISION NUMBER	REVISION DATE	DESCRIPTION	PAGES CHANGED
0	1/93	Initial release.	—
9	9/09	Changed column name in <i>Selection Table</i> to “Number of Receivers on Bus.”	1
10	9/14	Added MAX491MSD/PR and MAX491MSD/PR-T to data sheet. Updated <i>Absolute Maximum Ratings</i> .	2, 15
11	12/16	Updated Table 2	10

For pricing, delivery, and ordering information, please contact Maxim Direct at 1-888-629-4642, or visit Maxim Integrated's website at www.maximintegrated.com.

Maxim Integrated cannot assume responsibility for use of any circuitry other than circuitry entirely embodied in a Maxim Integrated product. No circuit patent licenses are implied. Maxim Integrated reserves the right to change the circuitry and specifications without notice at any time. The parametric values (min and max limits) shown in the Electrical Characteristics table are guaranteed. Other parametric values quoted in this data sheet are provided for guidance.