

13	12	11	10	9	8	7	6	5	4	3	2	1
ITEM NUMBER	DIMENSION "A"	HEXAGONAL SCREWLOCKS PACKAGED WITH CONNECTORS	SCREWLOCK ITEM NUMBER (SEE SD-70982-****)	PACKAGED PER PACKAGING SPECIFICATION								
75134-1000	.092±.010/2.34±0.25	NO		PK-70873-0291								
75134-1001	.092±.010/2.34±0.25	YES	70982-1003; 4-40 INTERNAL THD	PK-70873-0686								

NOTES:

1) MATERIALS:

HOUSING: GLASS FILLED LCP (LIQUID CRYSTAL POLYMER), UL94 V-0, COLOR NATURAL.
 STICK HOUSING: GLASS FILLED LCP (LIQUID CRYSTAL POLYMER), UL94 V-0, COLOR BLACK.
 TERMINALS: COPPER ALLOY.
 OUTER SHELL: DEEP DRAWN STEEL.
 HEXAGONAL SCREWLOCK: STEEL.

2) PLATING :

TERMINAL: SELECTIVE GOLD (Au) FLASH IN CONTACT AREA;
 THICKNESS= 2 TO 10 MICROINCHES/0.05 TO 0.25 MICROMETERS;
 SELECTIVE TIN (Sn) ALLOY IN THE PC TAIL AREA;
 THICKNESS=100 MICROINCHES/2.54 MICROMETERS MINIMUM;
 NICKEL (Ni) UNDERPLATE OVER ENTIRE PIN.

OUTER SHELL: 150 MICROINCHES/3.81 MICROMETERS MINIMUM OF BRIGHT TIN
 OVER 50 MICROINCHES/1.27 MICROMETERS MINIMUM OF NICKEL
 OVER COPPER FLASH (OPTIONAL).

3) CONFORMS TO PRODUCT SPECIFICATION PS-75134-001.

4) THREAD GAGE MAY REQUIRE UP TO 1 INCH-POUND/0.113 NEWTON-METER OF TORQUE DURING GAGING PROCESS.

5) SEE CHART FOR PACKAGING.

6) PART COMPLIES WITH CLASS B OF COSMETIC SPECIFICATION PS-45499-002

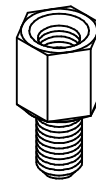
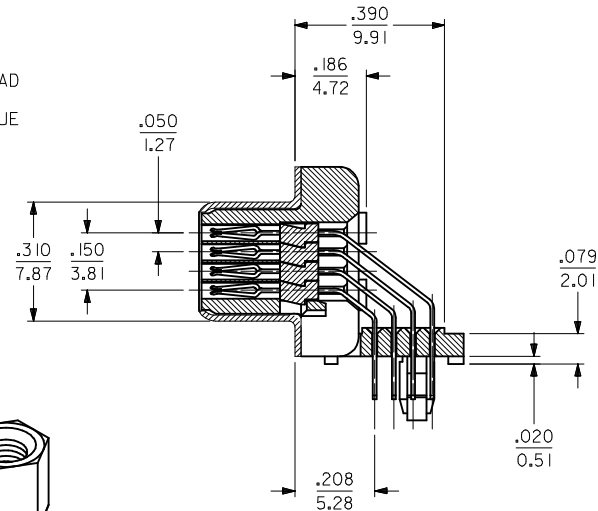
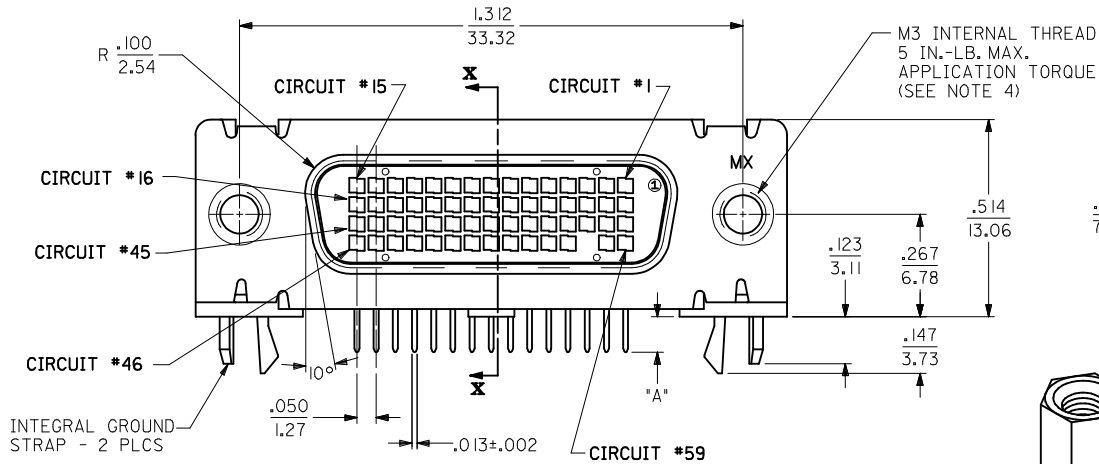
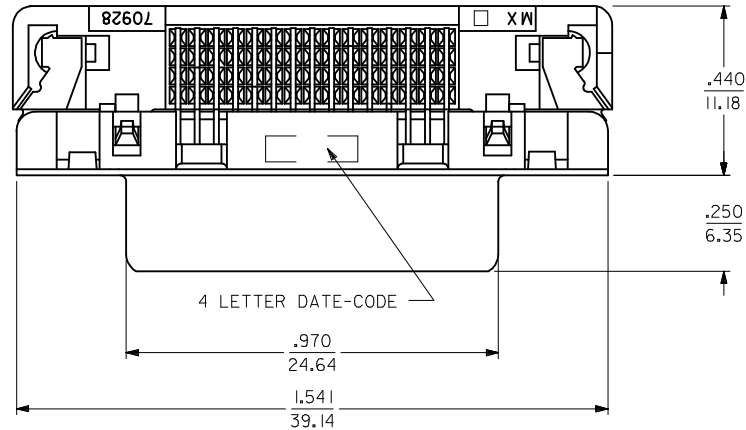

OPTIONAL
HEXAGONAL SCREWLOCK

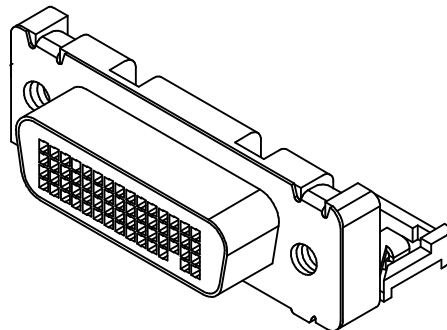

MOD PANEL CUT-OUT EC NO: UCP2012-0335 DRW:DMORGAN 2011/08/05 CHK:DMPOFF 2014/04/11 APPR:SMILLER 2014/05/12	QUALITY SYMBOLS ▽=0 ▽=0 ▽=0	GENERAL TOLERANCES (UNLESS SPECIFIED)		DIMENSION STYLE		SCALE	DESIGN UNITS	THIRD ANGLE PROJECTION		
				IN/MM		4:1	INCH			
				DRAWN BY DATE		TITLE				
				CHECKED BY DATE		SALES DMS-59 RECEPTACLE LFH .050/1.27 PITCH RIGHT ANGLE I/O 59 CKT				
		APPROVED BY DATE		SMILLER 2002/10/18						
		ANGULAR ±1/2°		MATERIAL NO.		DOCUMENT NO.		SHEET NO.		
		DRAFT WHERE APPLICABLE MUST REMAIN WITHIN DIMENSIONS		SEE TABLE		SD-75134-001		1 OF 2		
				SIZE C		THIS DRAWING CONTAINS INFORMATION THAT IS PROPRIETARY TO MOLEX INCORPORATED AND SHOULD NOT BE USED WITHOUT WRITTEN PERMISSION				

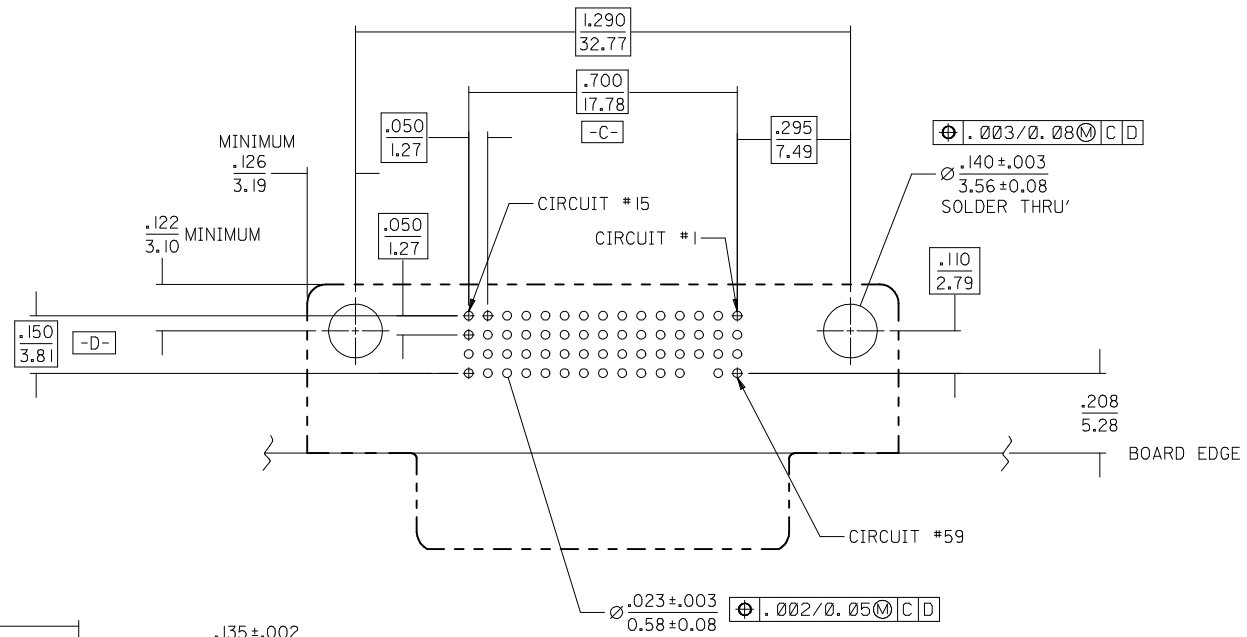

COMPONENT SIDE
RECOMMENDED P.C.B. LAYOUT

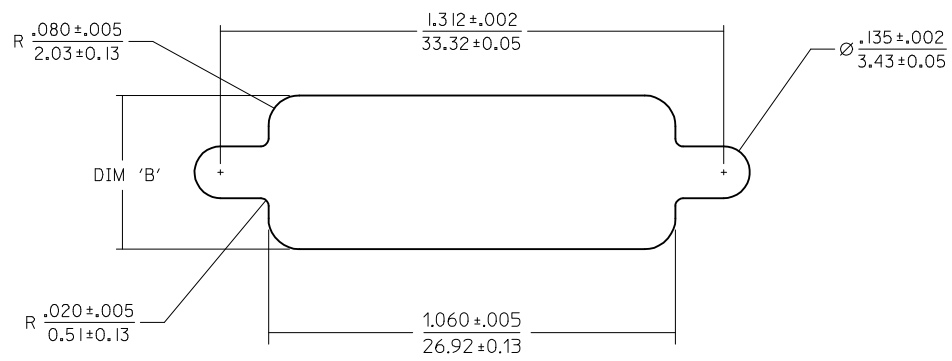

RECOMMENDED PANEL CUT-OUT

DIMENSION 'B'	MAXIMUM PANEL THICKNESS
.400±.005/10.16±0.13	.039/0.99
.420±.005/10.67±0.13	.064/1.63

SEE SHEET 1 EC NO: UCP2012-0335 DRWING: DMORGAN 2011/08/05 CHKD: MPOFF 2014/04/11 APPR: SMILLER 2014/05/12	QUALITY SYMBOLS ▽=0 ▽=0 ▽=0	GENERAL TOLERANCES (UNLESS SPECIFIED) <table border="1"> <thead> <tr> <th></th> <th>mm</th> <th>INCH</th> </tr> </thead> <tbody> <tr> <td>4 PLACES</td> <td>± .---</td> <td>± .---</td> </tr> <tr> <td>3 PLACES</td> <td>± .---</td> <td>± .010</td> </tr> <tr> <td>2 PLACES</td> <td>± 0.25</td> <td>± .015</td> </tr> <tr> <td>1 PLACE</td> <td>± 0.38</td> <td>± .---</td> </tr> <tr> <td>0 PLACE</td> <td>± .---</td> <td>± .---</td> </tr> </tbody> </table>		mm	INCH	4 PLACES	± .---	± .---	3 PLACES	± .---	± .010	2 PLACES	± 0.25	± .015	1 PLACE	± 0.38	± .---	0 PLACE	± .---	± .---	DIMENSION STYLE IN/MM DRAWN BY: DMORGAN DATE: 2002/10/18 CHECKED BY: BBARKER DATE: 2002/10/18 APPROVED BY: SMILLER DATE: 2002/10/18	SCALE: 4:1 DESIGN UNITS: INCH THIRD ANGLE PROJECTION	TITLE: SALES DMS-59 RECEPTACLE LFH .050/1.27 PITCH RIGHT ANGLE I/O 59 CKT molex
		mm	INCH																				
	4 PLACES	± .---	± .---																				
	3 PLACES	± .---	± .010																				
	2 PLACES	± 0.25	± .015																				
1 PLACE	± 0.38	± .---																					
0 PLACE	± .---	± .---																					
	DRAFT WHERE APPLICABLE MUST REMAIN WITHIN DIMENSIONS	MATERIAL NO. SEE TABLE	DOCUMENT NO. SD-75134-001	SHEET NO. 2 OF 2																			
		SIZE: C THIS DRAWING CONTAINS INFORMATION THAT IS PROPRIETARY TO MOLEX INCORPORATED AND SHOULD NOT BE USED WITHOUT WRITTEN PERMISSION																					