

**RO3144E-1**

**916.5 MHz  
SAW  
Resonator**

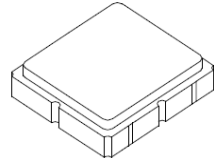

**SM3030-6 Case  
3.0 X 3.0**

- **Ideal for 916.5 MHz Remote Control and Data Telemetry Transmitters**
- **Very Low Series Resistance**
- **Quartz Stability**
- **Complies with Directive 2002/95/EC (RoHS)**
- **Tape and Reel Standard per ANSI/EIA-481**
- **Moisture Sensitivity Level: 1**
- **AEC-Q200 Qualified**

The RO3144E-1 is a true one-port, surface-acoustic-wave (SAW) resonator in a surface-mount ceramic case. It provides reliable, fundamental-mode stabilization of fixed-frequency transmitters operating at 916.5 MHz. This SAW is designed specifically for remote control and data telemetry transmitters operating in the USA under FCC Part 15 regulations and in Canada under DoC RSS-210.

**Absolute Maximum Ratings**

Rating	Value	Units
Input Power Level	0	dBm
DC Voltage	12	VDC
Storage Temperature	-40 to +125	°C
Operating Temperature Range	-40 to +125	°C
Soldering Temperature	260	°C

**Electrical Characteristics**

Characteristic		Sym	Notes	Minimum	Typical	Maximum	Units
Frequency, +25°C		f <sub>C</sub>		916.300		916.700	MHz
Tolerance from 916.5 MHz						±200	
		Δf <sub>C</sub>					
Insertion Loss		IL			1.2	1.6	dB
Quality Factor	Unloaded Q	Q <sub>U</sub>			6400		
	50 Ω Loaded Q	Q <sub>L</sub>			780		
Temperature Stability	Turnover Temperature	T <sub>O</sub>		15	25	40	°C
	Turnover Frequency	f <sub>O</sub>			f <sub>c</sub>		MHz
	Frequency Temperature Coefficient	FTC			0.032		ppm/°C <sup>2</sup>
Frequency Aging	Absolute Value during the First Year	fA			10		ppm
DC Insulation Resistance between Any Two Terminals				1.0			MΩ
RF Equivalent RLC Model	Motional Resistance	R <sub>M</sub>			14		Ω
	Motional Inductance	L <sub>M</sub>			15.4		μH
	Motional Capacitance	C <sub>M</sub>			1.9		fF
	Transducer Static Capacitance	C <sub>O</sub>			1.9		pF
Test Fixture Shunt Inductance		L <sub>TEST</sub>			16		nH
Lid Symbolization: Y = Year, WW = Week, S = Shift				769, YWWS			
Standard Reel Quantity	Reel Size 7 Inch			500 Pieces / Reel			
	Reel Size 13 Inch			3000 Pieces / Reel			

 **CAUTION: Electrostatic Sensitive Device. Observe precautions for handling.**

**NOTES:**

1. The design, manufacturing process, and specifications of this device are subject to change.
2. US or International patents may apply.
3. RoHS compliant from the first date of manufacture.

## Electrical Connections

The SAW resonator is bidirectional and may be installed with either orientation. The two terminals are interchangeable and unnumbered. The callout NC indicates no internal connection. The NC pads assist with mechanical positioning and stability. External grounding of the NC pads is recommended to help reduce parasitic capacitance in the circuit.

Pin	Connection
1	NC
2	Terminal
3	NC
4	NC
5	Terminal
6	NC

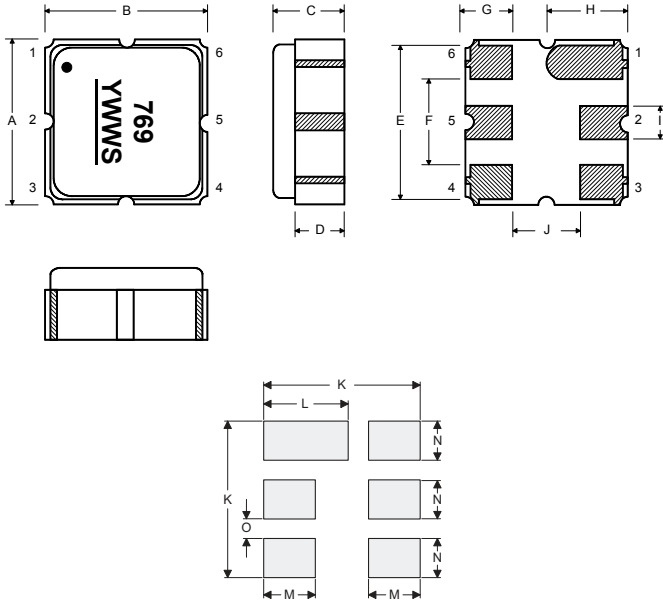

## Case and Typical PCB Land Dimensions

Ref	mm			Inches		
	Min	Nom	Max	Min	Nom	Max
A	2.87	3.00	3.13	0.113	0.118	0.123
B	2.87	3.00	3.13	0.113	0.118	0.123
C	1.12	1.25	1.38	0.044	0.049	0.054
D	0.77	0.90	1.03	0.030	0.035	0.040
E	2.67	2.80	2.93	0.105	0.110	0.115
F	1.47	1.60	1.73	0.058	0.063	0.068
G	0.72	0.85	0.98	0.028	0.033	0.038
H	1.37	1.50	1.63	0.054	0.059	0.064
I	0.47	0.60	0.73	0.019	0.024	0.029
J	1.17	1.30	1.43	0.046	0.051	0.056
K		3.20			0.126	
L		1.70			0.067	
M		1.05			0.041	
N		0.81			0.032	
O		0.38			0.015	

## Equivalent RLC Model

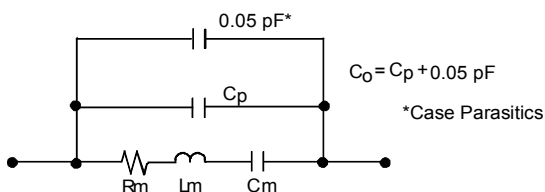

## Temperature Characteristics

The curve shown accounts for resonator contribution only and does not include external LC component temperature effects.

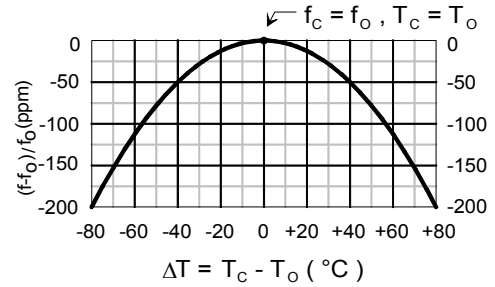

## Characterization Test Circuit

Inductor  $L_{\text{TEST}}$  is tuned to resonate with the static capacitance,  $C_0$ , at  $F_c$ .

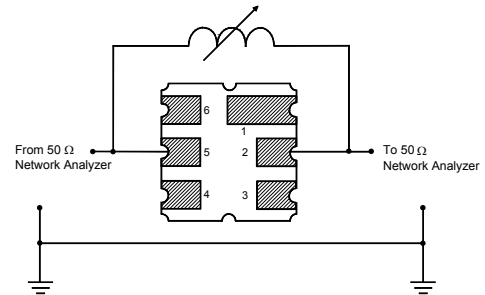

## Power Dissipation Test

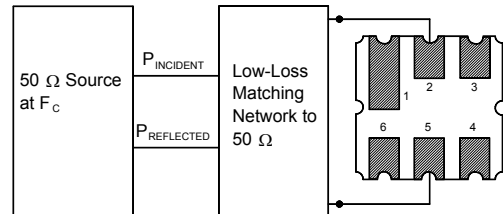

## Example Application Circuits

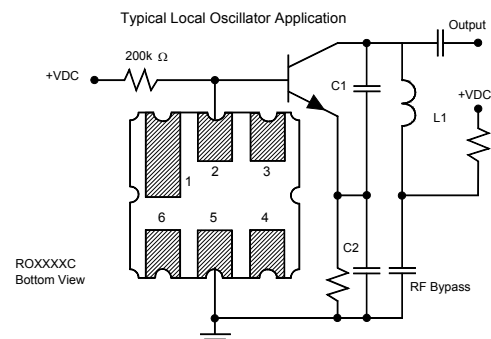
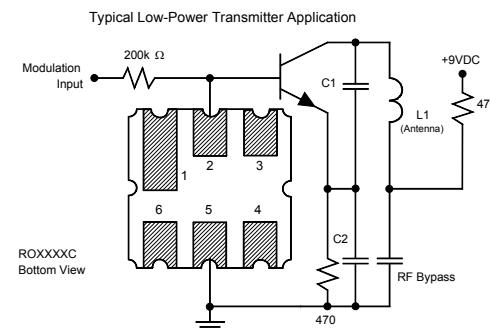

## Recommended Reflow Profile

1. Preheating shall be fixed at 150~180°C for 60~90 seconds.
2. Ascending time to preheating temperature 150°C shall be 30 seconds min.
3. Heating shall be fixed at 220°C for 50~80 seconds and at 260°C +0/-5°C peak (10 seconds).
4. Time: 5 times maximum.

