

## Specification

### 1.25G Ethernet Optical Bypass Module

#### Quad Ports 1.25G Base-SX

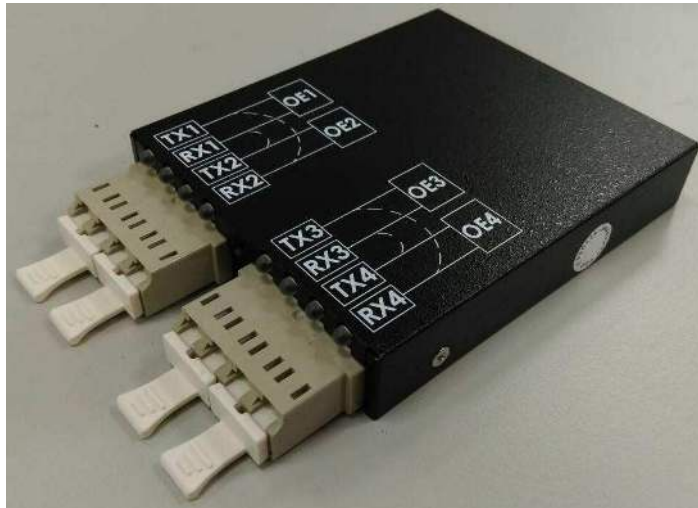

**O B M - B 3 B H 4 - E 0 1**

## Features

- **Reliable Passive Fiber Bypass (Latching)**
- **Low Return Loss**
- **Available in 50/125µm Multimode Fiber**
- **PCB Mountable Type**
- **Fast Ethernet Standard Compliant**
- **Digital Diagnostic SFF-8472 Rev.10.2 Compliant**
- **SONET/SDH Standard Compliant**
- **Two Quad LC Adapter**
- **1.25 G-BASE-SX are available**
- **Compliant with CE & FCC Standard**
- **Compact Format and ROHS Compliant**

## Product Overview

Formerica's Quad Port 1.25 Gbit/s Optical Bypass Module(OBM) is a compact module that contains four 1.25 G Base-SX ports and can be integrated with I/O port controllers in a Network Interface Card (NIC). This module is targeted for maintaining network connectivity when power failure or system fails in an In-Line Network System.

Formerica's Quad Port 1.25 Gbit/s Optical Bypass Module supports Normal and Bypass modes, and can be configured to perform the Block mode. In Normal mode, two ports function independently. In Bypass mode, signal packets received from one port are loop-backed to the adjacent port. In Block mode, the module blocks the route.

Formerica's Quad Port 1.25 Gbit/s Optical Bypass Module can Bypass or Block its I/O ports upon a host system failure, power off, or by software request. Formerica's Quad Port 1.25 Gbits Optical Bypass Module can be integrated with any brand's Controllers CPU. It is suitable for connecting with in-line equipment for power failure or system maintenance.

When the In-Line unit is not on or is in bypass mode, the relays within the OBM are set to bridge the optical signals directly through the optical switch, completely bypassing the In-Line equipment.

Formerica's OBM module provides excellent performance and reliable Optical Bypass and Block functions. All routing fibers, switches and electronics network are enclosed in a safe and compact housing which provides safe and space-saving to networking equipment.

Block Diagram and Optical Paths

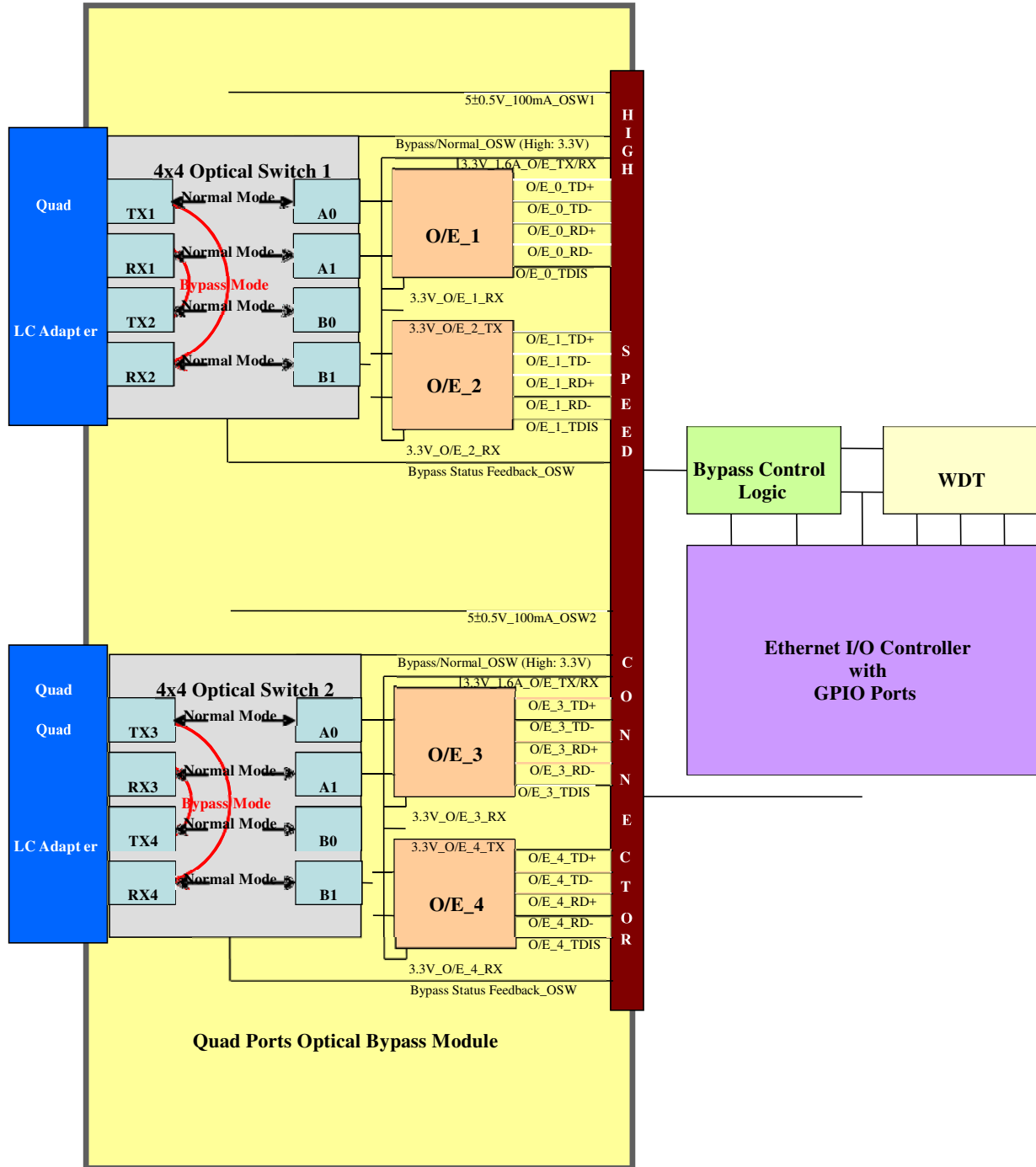

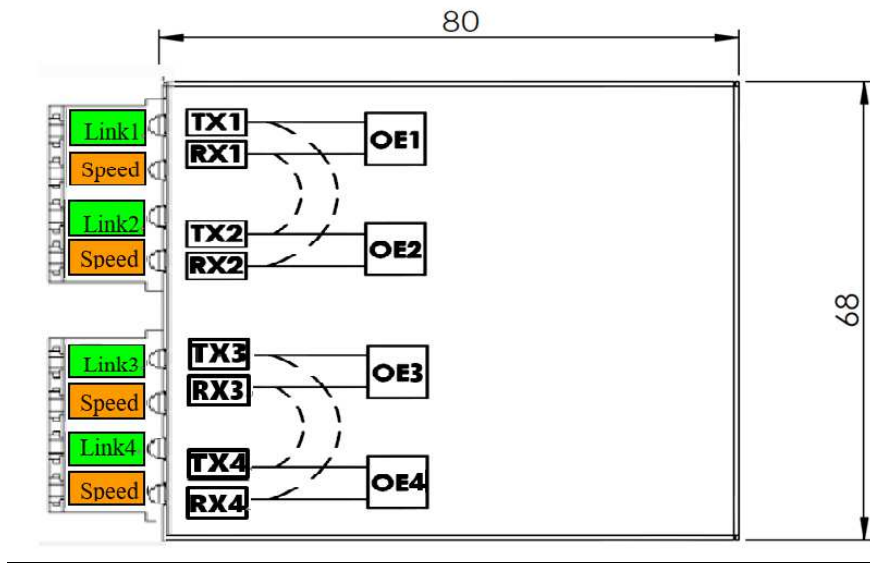

- Link1, Link2, Link3, Link4 indications:  
Green: Link
- Speed1, Speed2, Speed3, Speed4 indications:  
Orange: Data rate 1.25G

### Module Pin Out

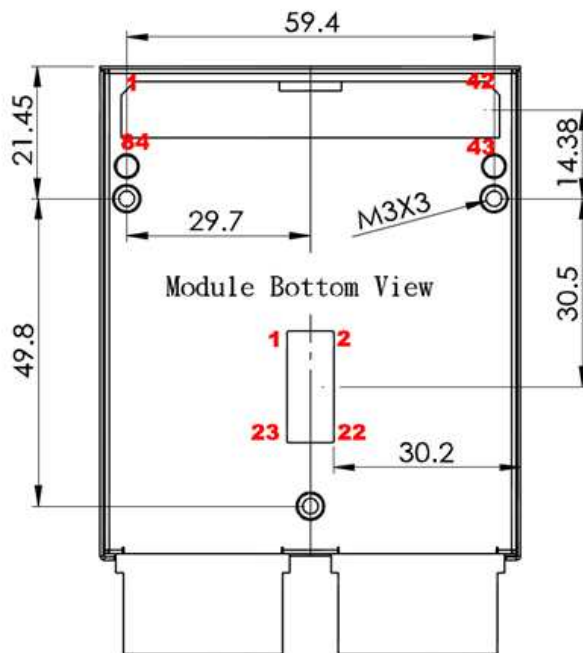

**84 PIN Assignments**

Pin Number	Name	I/O	Function	Note
1	Vcc5_2		5.0V Power Supper (OSW2 Power)	
2	GND			
3	On-Line	O	1K Ohm to Ground	
4	GND			
5	OE1 TX Disable	I	Transmitter Disable for OE-1	2
6	OE1 TX Fault	O	Transmitter Fault Indication for OE-1	1
7	OE1 MOD-DEF2	I/O	2 Wire Serial ID Interface (Data) for OE-1	3
8	OE1 MOD-DEF1	I	2 Wire Serial ID Interface (Clock) for OE-1	3
9	OE1 Vcc		3.3V for Tx1 Power Supply and Rx1 Power Supply – 300mA	
10	OE1-Link	I	OE1-Link LED Indicator (Voltage Low/ LED Green)	
11	OE1-Speed	I	OE1-Speed LED Indicator (Voltage Low / LED Orange)	
12	OE1 Rate Select	I	NA	
13	GND			
14	OE3 TX Disable	I	Transmitter Disable for OE-3	2
15	OE3 TX Fault	O	Transmitter Fault Indication for OE-3	1
16	OE3 MOD-DEF2	I/O	2 Wire Serial ID Interface (Data) for OE-3	3
17	OE3 MOD-DEF1	I	2 Wire Serial ID Interface (Clock) for OE-3	3
18	OE3 Vcc		3.3V for Tx3 Power Supply and Rx3 Power Supply – 300mA	
19	OE3-Link	I	OE3-Link LED Indicator (Voltage Low/ LED Green)	
20	OE3-Speed	I	OE3-Speed LED Indicator (Voltage Low / LED Orange)	
21	OE3 Rate Select	I	NA	
22	GND			
23	OE2 TX Disable	I	Transmitter Disable for OE-2	2
24	OE2 TX Fault	O	Transmitter Fault Indication for OE-2	1
25	OE2 MOD-DEF2	I/O	2 Wire Serial ID Interface (Data) for OE-2	3
26	OE2 MOD-DEF1	I	2 Wire Serial ID Interface (Clock) for OE-2	3
27	OE2 Vcc		3.3V for Tx2 Power Supply and Rx2 Power Supply – 300mA	

28	OE-2-Link	I	OE2-Link LED indicator (Voltage Low / LED Green)	
29	OE-2-Speed	I	OE2-Speed LED indicator (Voltage Low / LED Orange)	
30	OE2 Rate Select	I	NA	
31	GND			
32	OE4 TX Disable	I	Transmitter Disable for OE-4	2
33	OE4 TX Fault	O	Transmitter Fault indication for OE-4	1
34	OE4 MOD-DEF2	I/O	2 Wire Serial ID Interface (Data) for OE-4	3
35	OE4 MOD-DEF1	O	2 Wire Serial ID Interface (Clock) for OE-4	3
36	OE4 Vcc4		3.3V for Tx4 Power Supply and Rx4 Power Supply – 300mA	
37	OE-4-Link	I	OE4-Link LED Indicator (Voltage Low / LED Green)	
38	OE-4-Speed	I	OE4-Speed LED Indicator (Voltage Low / LED Orange)	
39	OE4 Rate Select	I	NA	
40	GND			
41	GND			
42	Vcc5_1		5.0V Power Supply (OSW 1 Power)	8
43	OSW 1 N1	I	Change to Normal mode for OSW1	7/9
44	OSW 1 B1	I	Change to Bypass mode for OSW1	7/9
45	OSW 1 State Output	O	High=Normal Mode, Low=Bypass Mode for OSW1	
46	OE4 GND		OE4 Signal Ground	
47	OE4 RD-	O	OE4 Inversed Data Output	5
48	OE4 RD+	O	OE4 Data Output	5
49	OE4 GND		OE4 Signal Ground	
50	OE4 GND		OE4 Signal Ground	
51	OE4 TD+	I	OE4 Data Input	6
52	OE4 TD-	I	OE4 Data Input	6
53	OE4 GND		OE4 Signal Ground	
54	OE4 LOS	O	Loss of Signal for OE-4	4
55	OE2 LOS	O	Loss of Signal for OE-2	4
56	OE2 GND		OE2 Signal Ground	
57	OE2 RD-	O	OE2 Inversed Data Output	5
58	OE2 RD+	O	OE2 Data Output	5
59	OE2 GND		OE2 Signal Ground	
60	OE2 GND		OE2 Signal Ground	6

61	OE2 TD+	I	OE2 Data Input	6
62	OE2 TD-	I	OE2 Inversed Data Input	
63	OE2 GND		OE2 Signal Ground	
64	OE3 GND		OE3 Signal Ground	
65	OE3 RD-	O	OE3 Inversed Data Output	5
66	OE3 RD+	O	OE3 Data Output	5
67	OE3 GND		OE3 Signal Ground	
68	OE3 GND		OE3 Signal Ground	
69	OE3 TD+	I	OE3 Data Input	6
70	OE3 TD-	I	OE3 Inversed Data Input	6
71	OE3 GND		OE3 Signal Ground	
72	OE3 LOS	O	Loss of Signal for OE-3	4
73	OE1 LOS	O	Loss of Signal for OE-1	4
74	OE1 GND		OE1 Signal Ground	
75	OE1 RD-	O	OE1 Inversed Data Output	5
76	OE1 RD+	O	OE1 Data Output	5
77	OE1 GND		OE1 Signal Ground	
78	OE1 GND		OE1 Signal Ground	
79	OE1 TD+	I	OE1 Data Input	6
80	OE1 TD-	I	OE1 Inversed Data Input	6
81	OE1 GND		OE1 Signal Ground	
82	OSW 2 N2	I	Change to Normal mode for OSW2	7/9
83	OSW 2 B2	I	Change to Bypass mode for OSW2	7/9
84	OSW 2 State Output	O	High=Normal mode, Low=Bypass mode for OSW2	

**23 PIN Assignments**

Pin Number	Name	I/O	Function	Note
1	Vcc5_1		5.0V Power Supper (OSW1 Power)	
2	Vcc5_1		5.0V Power Supper (OSW1 Power)	
3	OE4-Speed	I	OE4-Speed LED Indicator (Voltage Low / LED Orange)	
4	OE1-Link	I	OE1-Link LED Indicator (Voltage Low/ LED Green)	
5	OE4-Link	I	OE4-Link LED Indicator (Voltage Low / LED Green)	
6	OE1-Speed	I	OE1-Speed LED Indicator (Voltage Low / LED Orange)	
7	OE3-Speed	I	OE3-Speed LED Indicator (Voltage Low / LED Orange)	
8	OE2-Link	I	OE2-Link LED indicator (Voltage Low / LED Green)	
9	OE3-Link	I	OE3-Link LED Indicator (Voltage Low/ LED Green)	
10	OE2-Speed	I	OE2-Speed LED indicator (Voltage Low / LED Orange)	
11	OSW 2 State Output	O	High=Normal mode, Low=Bypass mode for OSW2	
12	OSW 1 State Output	O	High=Normal Mode, Low=Bypass Mode for OSW1	
13	GND			
14	GND			
15	OSW 2 B2	I	Change to Bypass mode for OSW2	
16	OSW 1 B1	I	Change to Bypass mode for OSW1	
17	OSW 2 N2	I	Change to Normal mode for OSW2	
18	OSW 1 N1	I	Change to Normal mode for OSW1	
19			No Connector	
20			No Connector	
21			No Connector	
22	Vcc5_2		5.0V Power Supper (OSW2 Power)	
23	Vcc5_2		5.0V Power Supper (OSW2 Power)	



**Notes:**

1. TX Fault is an open collector/drain output, which should be pulled up with a 4.7K – 10K $\Omega$  resistor on the host board. Pull up voltage between 2.0V and VccT, R+0.3V. When high, output indicates a laser fault of some kind. Low indicates normal operation. In the low state, the output will be pulled to < 0.5V.
2. TX disable is an input that is used to shut down the transmitter optical output. It is pulled up within the module with a 4.7– 10 K  $\Omega$  resistor. Its states are:
  - Low (0 – 0.8V): Transmitter on
  - (>0.8, < 2.0V): Undefined
  - High (2.0 – 3.465V): Transmitter Disabled
  - Open: Transmitter Disabled
3. Mod-Def 1,2, These are the module definition pins. They should be pulled up with a 4.7K – 10K $\Omega$  resistor on the host board. The pull-up voltage shall be VccT or VccR (see Section IV for further details). Mod-Def 0 is grounded by the module to indicate that the module is present Mod-Def 1 is the clock line of two wire serial interface for serial ID Mod-Def 2 is the data line of two wire serial interface for serial ID
4. LOS (Loss of Signal) is an open collector/drain output, which should be pulled up with a 4.7K – 10K $\Omega$  resistor. Pull up voltage between 2.0V and VccT, R+0.3V. When high, this output indicates the received optical power is below the worst-case receiver sensitivity (as defined by the standard in use). Low indicates normal operation. In the low state, the output will be pulled to < 0.5V.
5. RD-/+: These are the differential receiver outputs. They are AC coupled 100 $\Omega$  differential lines which should be terminated with 100 $\Omega$  (differential) at the user SERDES. The AC coupling is done inside the module and is thus not required on the host board. The voltage swing on these lines will be between 350 and 850 mV differential (175 – 425 mV single ended) when properly terminated.
6. TD-/+: These are the differential transmitter inputs. They are AC-coupled, differential lines with 100 $\Omega$  differential termination inside the module. The AC coupling is done inside the module and is thus not required on the host board. The inputs will accept differential swings of 180 – 700 mV (90 – 350 mV single-ended).
7. Latching Type - The input is used to control the optical switch mode for OSW  
Normal mode: OSW N1/N2: > 3.75V and OSW B1/B2 < 0.5V and over 20ms.  
Bypass mode: OSW N1/N2: < 0.5V and OSW B1/B2 >3.75V and over 20ms
8. Non-Latching Type - High =Normal Mode, Low=Bypass Mode for OSW.
9. Non-Latching Type - Pin 43, 44, 82 and 83: Ground

**Absolute Maximum Ratings**

Parameter	Symbol	Min.	Typ.	Max.	Unit
Storage Temperature	Ts	-40		85	°C
Supply Voltage	Vcc	0		5	V

**Recommended Operating Conditions**

Parameter	Symbol	Min.	Typ.	Max.	Unit	Note
Case Operating Temperature	Top	0		70	°C	1
+5.0V Supply Voltage	Vcc5	4.75		5.25	V	Vcc 5
+3.3V Supply Voltage	Vcc3	3.10		3.50	V	
Relative Humidity (non -condensation)		5		85	%	
Data Rate		-100ppm	1.25	+100ppm	Gbps	

Note1 : Please see order information

**Electrical Characteristics**

Parameter	Symbol	Min.	Typ.	Max.	Unit	Note
+5.0V Supply Current	Icc5			100	m	
+3.3V Supply Current	Icc3			1200	m	
<b>Transmitter</b>						
Transmitter Differential Input	V <sub>DT</sub>	180		700	m	1
Transmitter Disable Input-High	V <sub>DISH</sub>	2		V <sub>CC</sub> +0.3	V	
Transmitter Disable Input-Low	V <sub>DISL</sub>	0		0.8	V	
Transmitter Fault Pull up Resistor	R <sub>TX</sub>	4.7		10	K	2
Transmitter Fault Output-High	V <sub>TXFH</sub>	2.4		V <sub>CC</sub>	V	2
Transmitter Fault Output-Low	V <sub>TXFL</sub>	0		0.5	V	2
<b>Receiver</b>						
Receiver Differential Output	V <sub>DR</sub>	350		850	m	3
Receiver LOS Load	R <sub>RXLO</sub>	4.7		10	K	2
LOS Output Voltage-High	V <sub>LOSH</sub>	2.4		V <sub>CC</sub>	V	2
LOS Output Voltage-Low	V <sub>LOSL</sub>	0		0.5	V	2
<b>Optical Switch</b>						
Latching Voltage-High	V <sub>LATH</sub>	4.75	5	5.25	V	
Latching Voltage-Low	V <sub>LATL</sub>	0		0.8	V	
Latching Resistance	R <sub>LAT</sub>		125		Ω	

**Notes:**

1. Internally AC coupled and terminated to 100Ohm differential load
2. Pull up to V<sub>CC</sub> on Host Board.
3. Internally AC coupled, but requires a 100Ohm differential termination at or internal to Serializer/Deserializer.

**Optical Characteristics** (Top=0~70°C, Data Rate=1.25Gb/sec, PRBS=2<sup>31</sup>-1 NRZ)

	Multimode Fiber Type	Min. Modal Bandwidth (MHz*km)	Operating Range (m)	Maximum Channel Intertion Loss (dB)
Operating Range	62.5um MMF OM1	200	0.5 to 137	2.53
	50um MMF OM2	500	0.5 to 550	3.42
	50um MMF OM3	2000	0.5 to 800	4.62

Parameter	Symbol	Min.	Typ.	Max.	Unit	Note
<b>Transmitter</b>						
Output Optical Power(Avg.)	P <sub>o</sub>	-9.5		-4	dB	1
Optical Extinction Ratio	ER	9			dB	
Center Wavelength	λ	830	850	860	nm	
Spectral Width (RMS)	σλ			0.85	nm	
<b>Receiver</b>						
Sensitivity (OMA)	PIN			-20	dB	1,2
Input Optical Wavelength	λ	830		860	nm	
Return Loss				-12	dB	
LOS-Deasserted (Avg.)	P <sub>SA</sub>			-20	dB	
LOS-Asserted (Avg.)	P <sub>SD</sub>	-34			dB	
LOS-Hysteresis	P <sub>SH</sub>	0.5			dB	
Overload	P <sub>MAX</sub>			-3	dB	
<b>Optical Switch</b>						
Wavelength Range	λ	670		980	nm	
Insertion Loss	OIL	0.9		1.8	dB	
Return Loss	ORL	30			dB	
Switch Time				8	ms	
Lifetime			≥10 <sup>7</sup>		tim	
Latching Resistance	RLAT		125		Ω	

**Notes:**

1. Normal Mode (Bypass off).
2. The sensitivity provided at a BER of 1×10<sup>-12</sup> or better with an input signal consisting of 10.3125Gb/s, 2<sup>31</sup>-1 PRBS

Package Outline Drawing (mm)

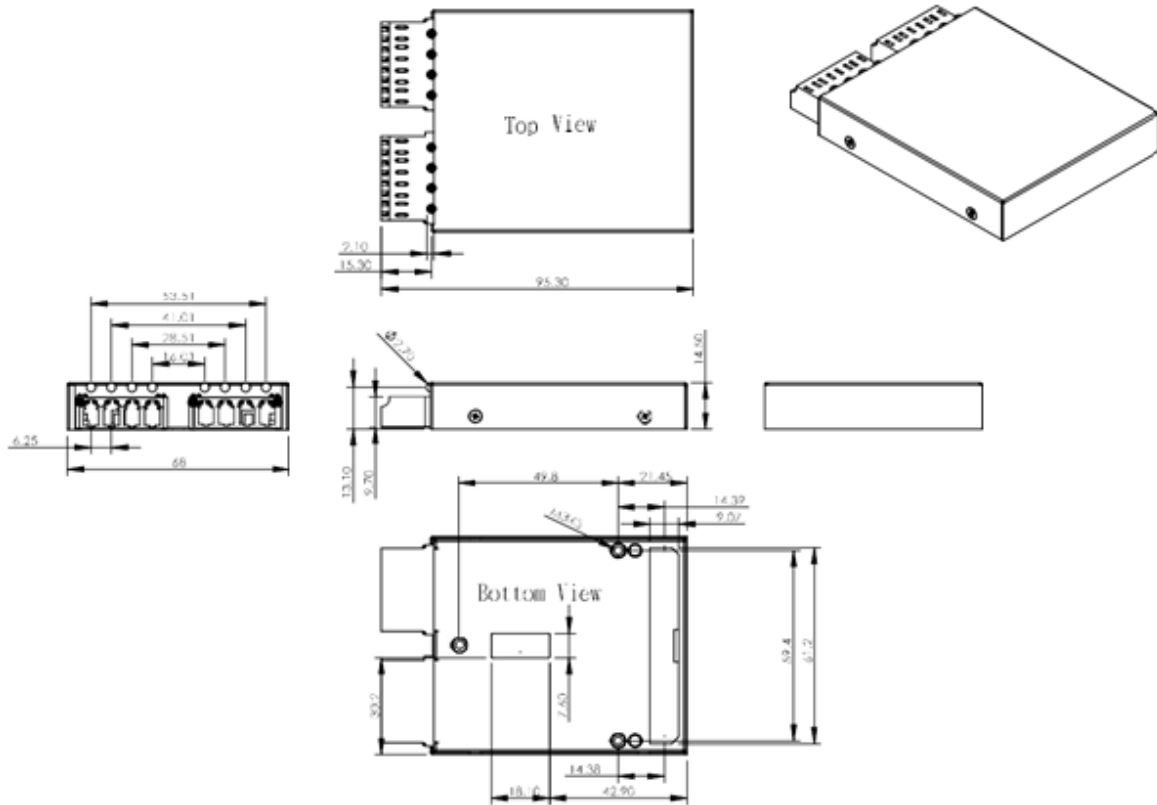

## ESD

Normal ESD precautions are required during the handling of this module. This transceiver is shipped in ESD protective packaging. It should be removed from the packaging and handled only in an ESD protected environment.

## Contact Information

**Formerica OptoElectronics Inc.**

5F-11, No.38, Taiyuan St., Zhubei City,

Hsinchu County 30265, Taiwan

Tel: +886-3-5600286

Fax: +886-3-5600239

**San Diego, CA**

Tel: 1-949-466-8069

[inquiry@formericaoe.com](mailto:inquiry@formericaoe.com)

[www.formericaoe.com](http://www.formericaoe.com)