



A Product Line of  
Diodes Incorporated



## SPECIFICATION FOR APPROVAL

|                   |  |
|-------------------|--|
| CUSTOMER          | _____  |
| NOMINAL FREQUENCY | 32.768000 KHz  |
| PRODUCT TYPE      | TYPE KD 5.0x3.2 SEAM SEALED CRYSTAL CLOCK OSCILLATOR |
| SPEC. NO. ( P/N ) | KD3270027Q   |
| CUSTOMER P/N      | _____  |
| ISSUE DATE        | January 29, 2018                                     |
| VERSION           | C  |

| APPROVED | PREPARED | QA |
|----------|----------|----|
|          |          |    |

### Diodes Incorporated

No.2, Ziqiang 5th Rd., Zhongli Industrial Park,  
Zhongli Dist., Taoyuan City 32063, Taiwan (R.O.C.)  
TEL: 886-3-451-8888  
FAX: 886-3-461-3865  
<https://www.diodes.com>

- \*Pb-free
- \*RoHS Compliant
- \*HF-Halogen Free
- \*REACH Compliant
- \*AEC-Q200 Compliant



# TYPE KD 5.0x3.2 SEAM SEALED CRYSTAL CLOCK OSCILLATOR

## KD3270027Q

VER. C 29-Jan-18

### ELECTRICAL SPECIFICATIONS

SRe Part Number : KD3270027Q

| Item                            | Symbol                         | Specifications      | Units | Notes                                 |
|---------------------------------|--------------------------------|---------------------|-------|---------------------------------------|
| Nominal Frequency               | Fo                             | 32.768000           | KHz   |                                       |
| Frequency Stability             | FT                             | ± 50                | ppm   | **See note                            |
| Operating Temperature Range     | TR                             | -40 to +85          | °C    |                                       |
| Supply Voltage                  | V <sub>DD</sub>                | +3.3 ± 10%          | V     |                                       |
| Logic Type                      | LT                             | LVC MOS             |       |                                       |
| Supply Current, Output Enabled  | I <sub>DD</sub> /OE            | 15                  | mA    | Max.                                  |
| Supply Current, Output Disabled | I <sub>DD</sub> /OD            | 10                  | µA    | Max.                                  |
| Duty Cycle (Symmetry)           | DC/SY                          | 45 / 55             | %     | Measured 50% of Waveform              |
| Rise / Fall Time                | T <sub>R</sub> /T <sub>F</sub> | 1000                | ns    | Max. Measured at 20 / 80% of Waveform |
| Output Voltage "0" Level        | V <sub>OL</sub>                | 10% V <sub>DD</sub> | V     | Max.                                  |
| Output Voltage "1" Level        | V <sub>OH</sub>                | 90% V <sub>DD</sub> | V     | Min.                                  |
| Output Load                     | CL                             | 15                  | pF    | Max.                                  |
| Jitter, Peak to Peak            | PK-PK                          | 50                  | ps    | Max. 100,000 Random Periods           |
| Start Up Time                   |                                | 2                   | ms    | Max.                                  |
| Storage Temperature Range       |                                | -55 to +125         | °C    |                                       |

※ This product doesn't include harmful substance that stipulated by SONY SS-00259 Level 1 and S-AT2-001 Level 1 standard. RoHS Compliant (Pb - Free).

\*\*Stability includes all combinations of Operating Temperature, Load changes, rated Input (Supply) Voltage changes, Initial Calibration Tolerance (25°C), Aging (1 year at 25°C Average Effective Ambient Temperature), Shock and Vibration.

#### Output Enable / Disable Function

| Parameter  | Min.               | Typ. | Max.               | Units | Notes          |
|--|--------------------|------|--------------------|-------|----------------|
| Input Voltage (Pin1), Output Enable                      | 0.7V <sub>DD</sub> |      |                    | V     | Or Open        |
| Input Voltage (Pin1), Output Disable (low power standby) |                    |      | 0.3V <sub>DD</sub> | V     | Output is Hi-Z |
| Internal Pullup Resistance                               |                    | 470  |                    | KΩ    |                |
| Output Disable Delay                                     |                    |      | 100                | ns    |                |
| Output Enable Delay                                      |                    |      | 10                 | ms    |                |

# TYPE KD 5.0x3.2 SEAM SEALED CRYSTAL CLOCK OSCILLATOR

## KD3270027Q

VER. C 29-Jan-18

### TEST CIRCUIT

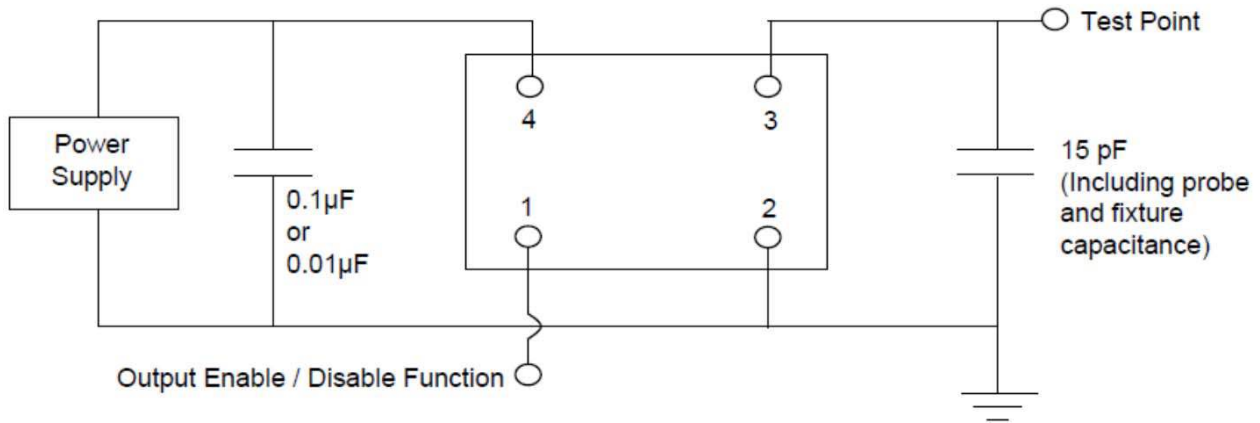

### OUTPUT WAVEFORM

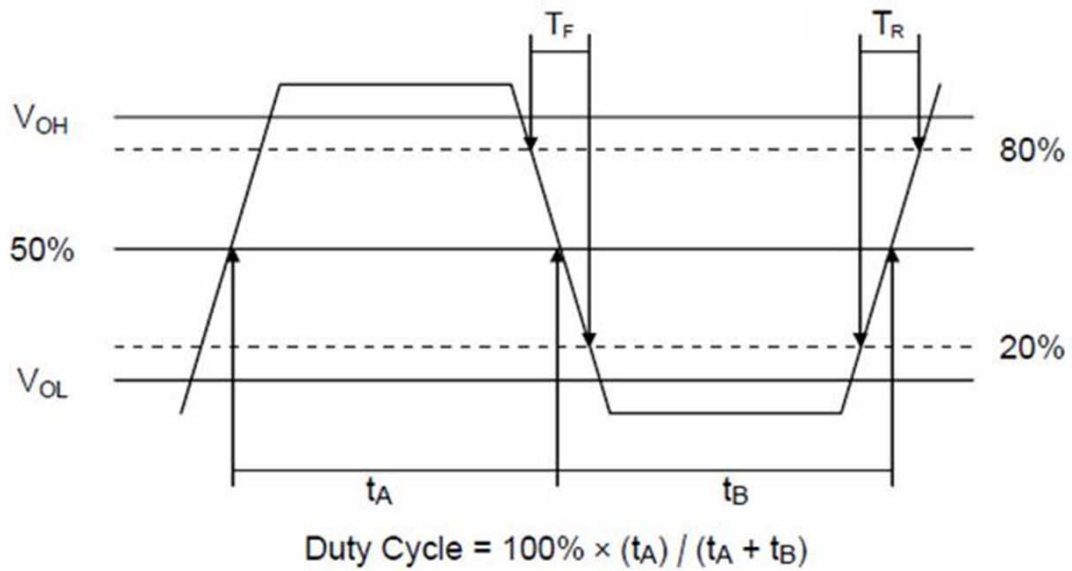

# TYPE KD 5.0x3.2 SEAM SEALED CRYSTAL CLOCK OSCILLATOR

**KD3270027Q**

VER. C 29-Jan-18

## AEC-Q200 RELIABILITY TEST SPECIFICATIONS:

### 1. Initial

- 1.1 Physical Dimensions: JESD22, Method JB1-100
- 1.2 External Visual: MIL-STD-883, Method 2009
- 1.3 Freq. Vs. Temperature: Per Specification/Datasheet

### 2. Mechanical

- 2.1 Mechanical Shock: MIL-STD-202 Method 213
- 2.2 Vibration: MIL-STD-202 Method 204
- 2.3 Solderability: J-STD-002
- 2.4 Board Flex: AEC Q200-005
- 2.5 Terminal Strength (SMD): AEC Q200-006

### 3.Environmental

- 3.1 Temp Cycle: JESD22, Method JA-104
- 3.2 Resistance to Solder Heat: MIL-STD-202 Method 210
- 3.3 High Temperature Operating Life: MIL-STD-202, Method 108
- 3.4 High Temp Exposure: MIL-STD-202, Method 108
- 3.5 High Temp & High Humidity: MIL-STD-202, Method 103
- 3.6 Thermal Shock: MIL-STD-202, Method 107

## SUGGESTED IR REFLOW PROFILE

\*As per IPC-JEDEC J-STD-020D

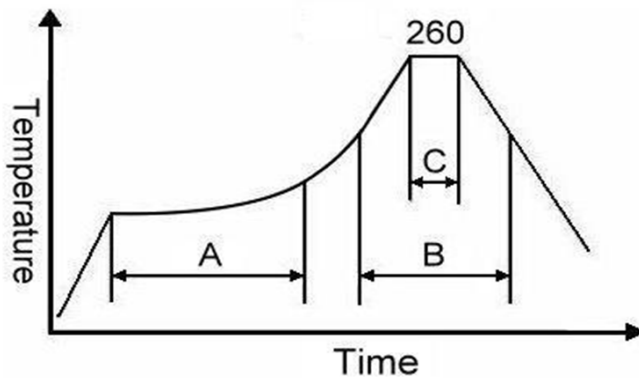

Note:

|   | Stage        | Temperature | Time       |
|---|--------------|-------------|------------|
| A | Preheat      | 150~200°C   | 60~120 Sec |
| B | Primary Heat | 217°C       | 60~150 Sec |
| C | Peak         | 260°C       | 10 Sec     |

# TYPE KD 5.0x3.2 SEAM SEALED CRYSTAL CLOCK OSCILLATOR

## KD3270027Q

VER. C 29-Jan-18

### MARKING

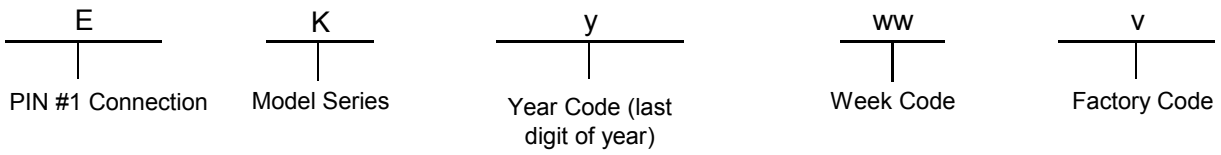

### MECHANICAL DRAWINGS ( Scale:None. Dimensions are in mm.)

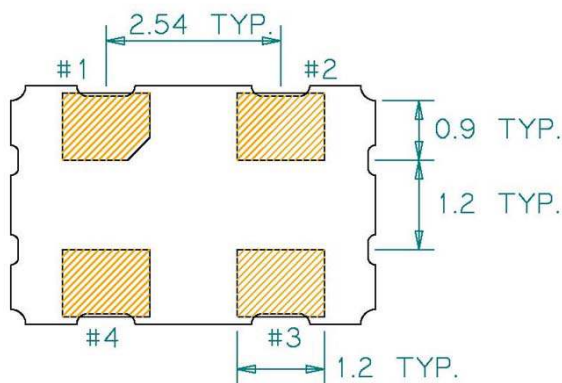
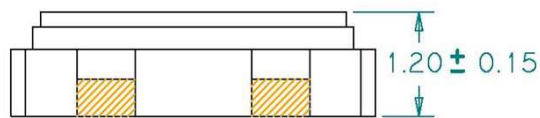
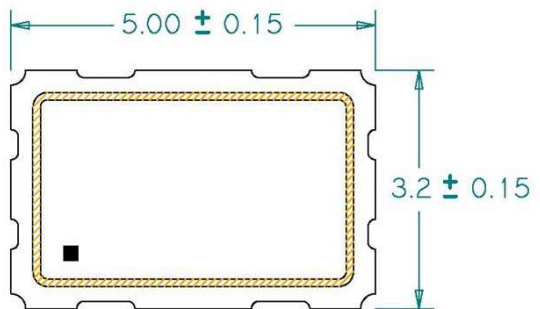

#### Recommended Land Pattern\*

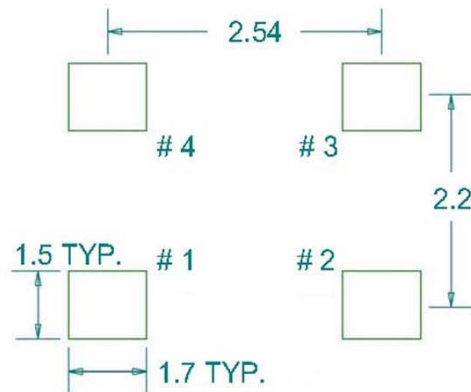

\*External high-frequency power decoupling is recommended. (see test circuit for minimum recommendation). To ensure optimal performance, do not route traces beneath the package.

| Pin | Function        |
|-----|-----------------|
| 1   | OE              |
| 2   | Ground          |
| 3   | Clock Output    |
| 4   | V <sub>DD</sub> |

# TYPE KD 5.0x3.2 SEAM SEALED CRYSTAL CLOCK OSCILLATOR

## KD3270027Q

VER. C 29-Jan-18

### TAPE&REEL

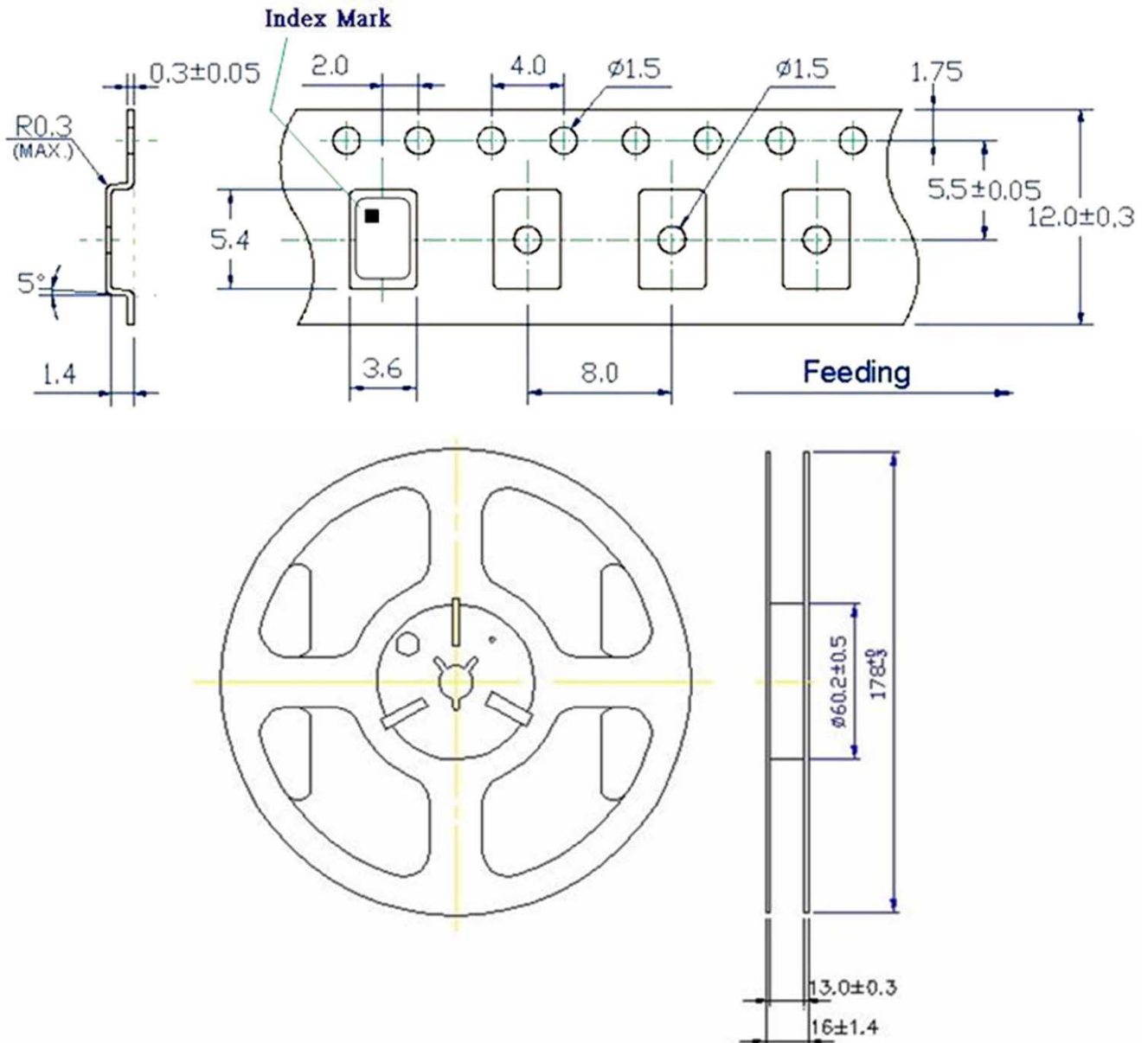

1. 230mm minimum leader which consist of carrier and/or tape followed by a minimum of 160mm of empty carrier tape sealed with cover tape.
2. 160mm minimum trailer of empty carrier tape sealed with cover tape.

# TYPE KD 5.0x3.2 SEAM SEALED CRYSTAL CLOCK OSCILLATOR

## KD3270027Q

VER. C 29-Jan-18

### PACKING

