

REVISIONS					
P	LTR	DESCRIPTION	DATE	DMN	APVD
A1		REVISED PER ECR-17-015922	07NOV2017	BDA	KR

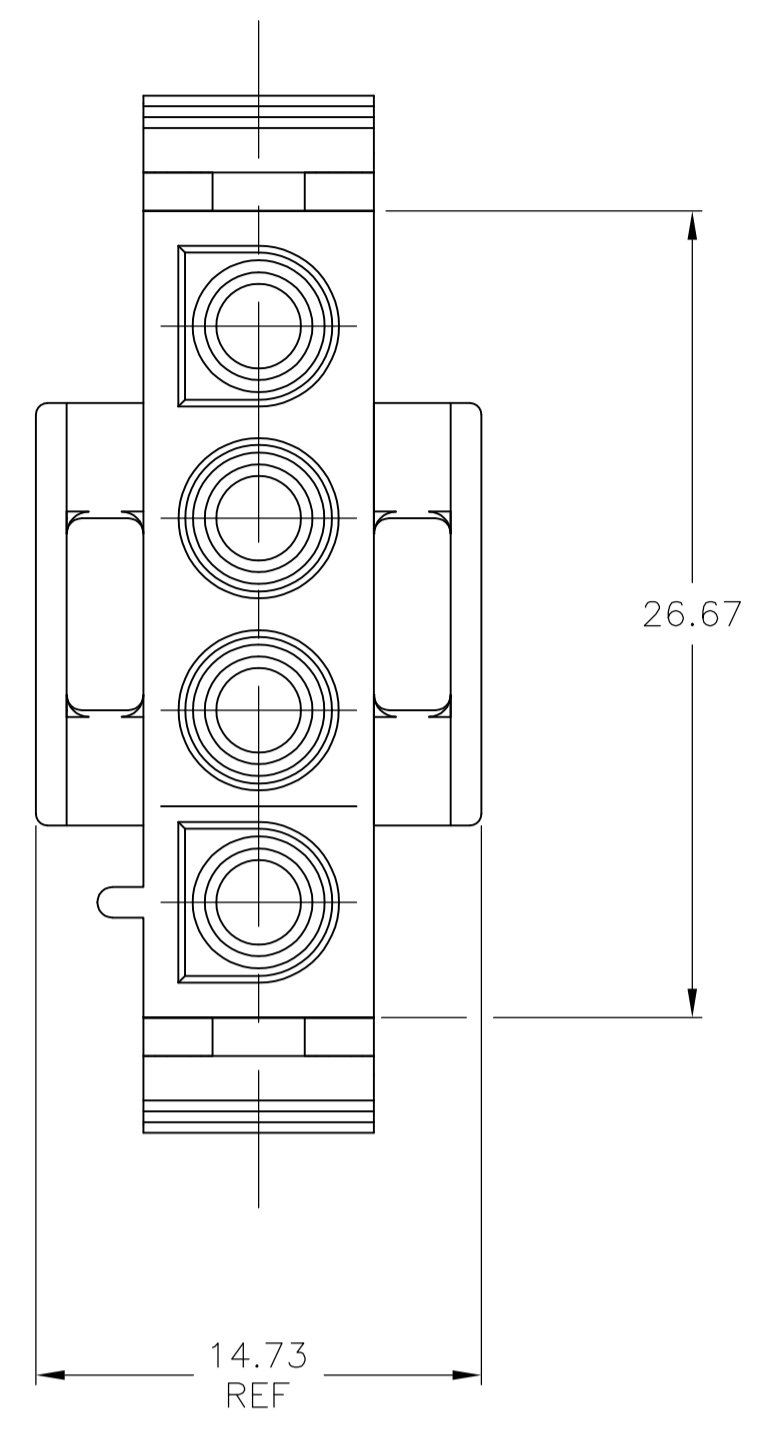

- MATES WITH APPROPRIATE UNIVERSAL MATE-N-LOK™ CAP OR HEADER.
 - SMALL NICKS ARE PERMITTED ON THE CIRCUIT TOWERS WHICH COULD INCREASE THE INITIAL HOUSING MATING FORCE BY UP TO 4.4 NEWTONS [1.0 LBS]. NO INDIVIDUAL NICKED TOWER SHALL INCREASE THIS FORCE BY OVER 2.2 NEWTONS [.5 LBS].
 - DIMENSIONS SHOWN REPRESENT PRODUCT IN DRY, AS MOLDED, CONDITION. ADDITIONAL 2% GROWTH DUE TO SUBSEQUENT MOISTURE ABSORPTION MAY OCCUR AND SHOULD BE ACCOUNTED FOR.
- △ FOUR RIBS EQUALLY SPACED, NO SPECIFIC ORIENTATION. SIX RIBS EQUALLY SPACED, NO SPECIFIC ORIENTATION, OPTIONAL.

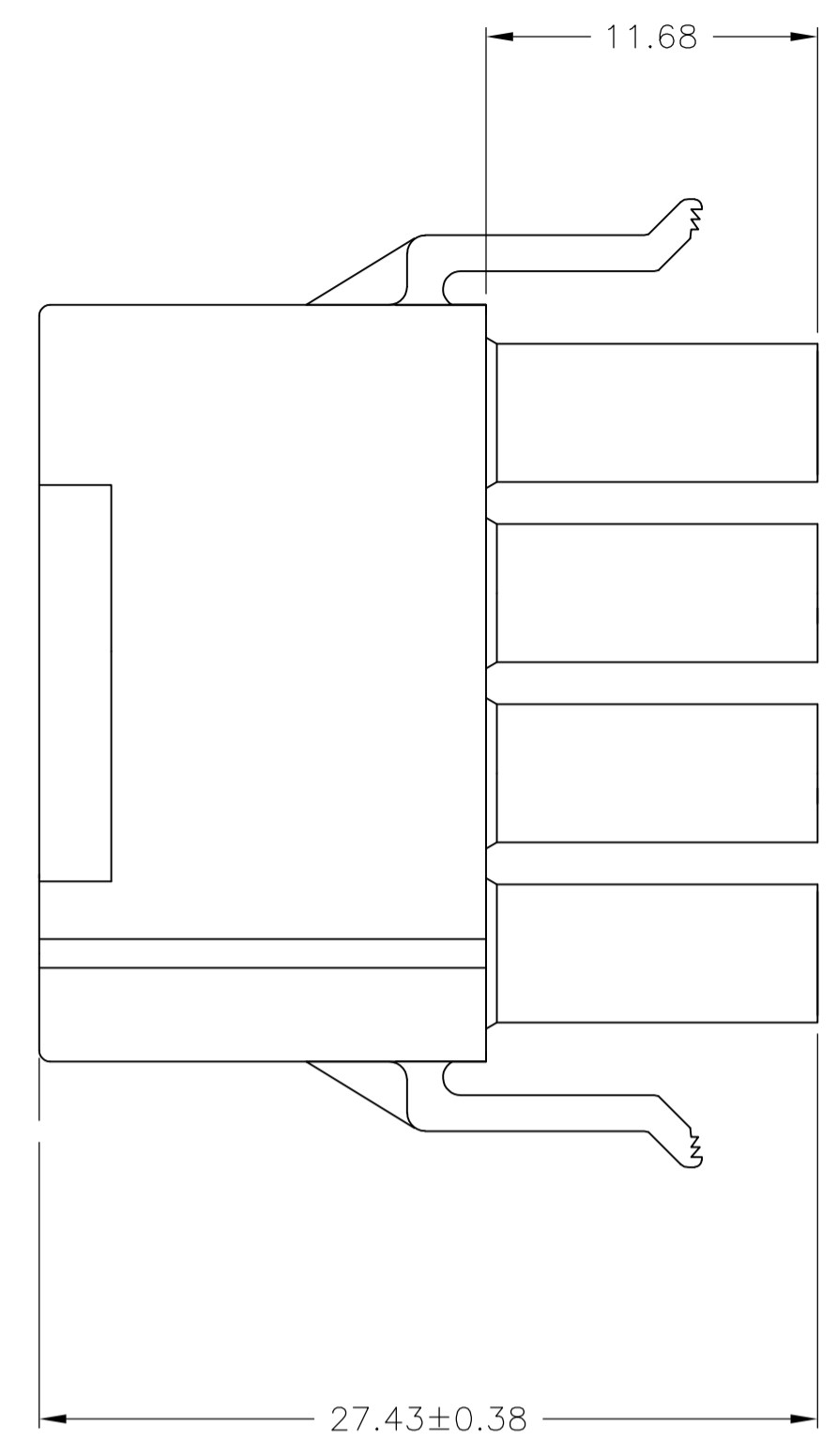
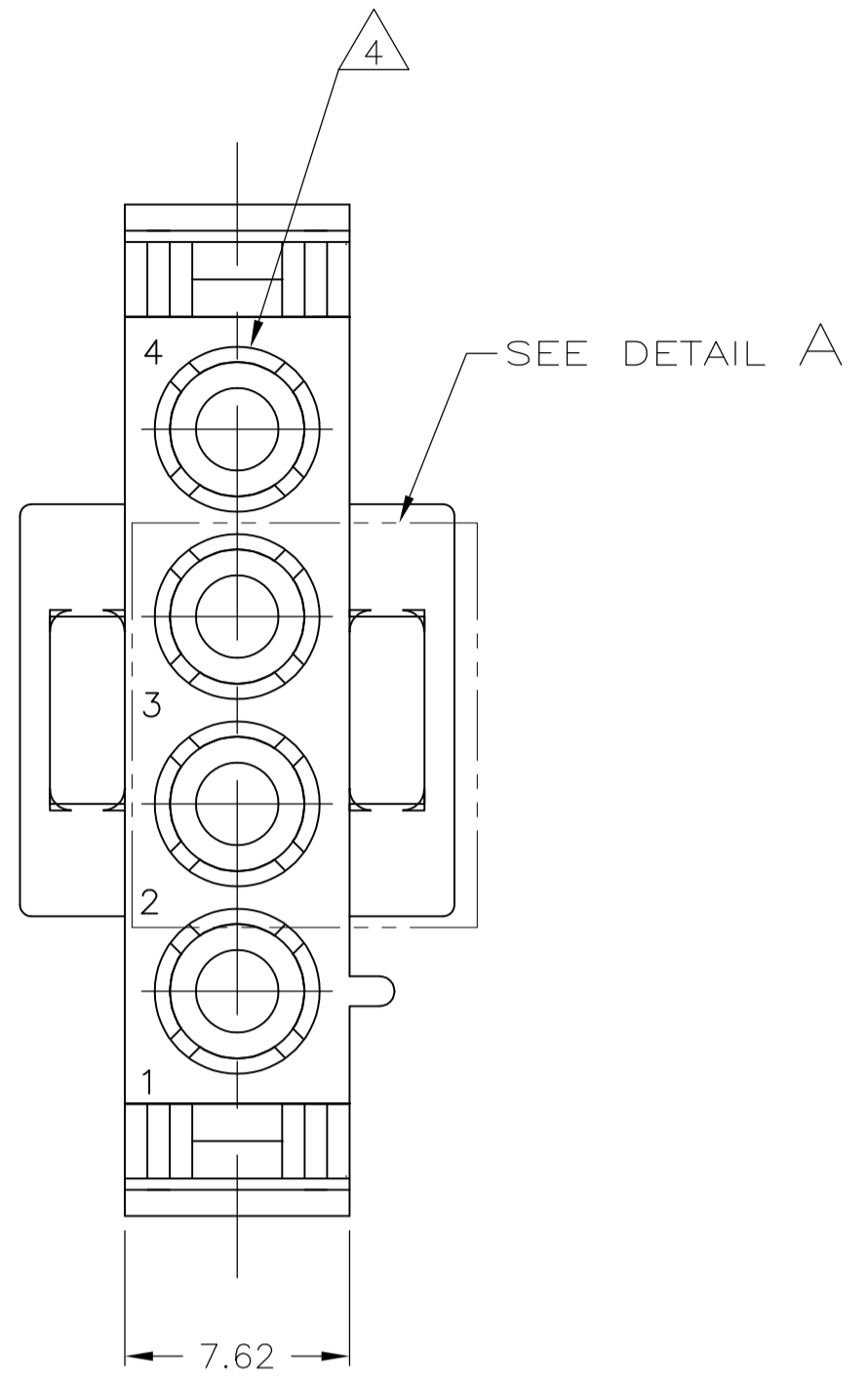
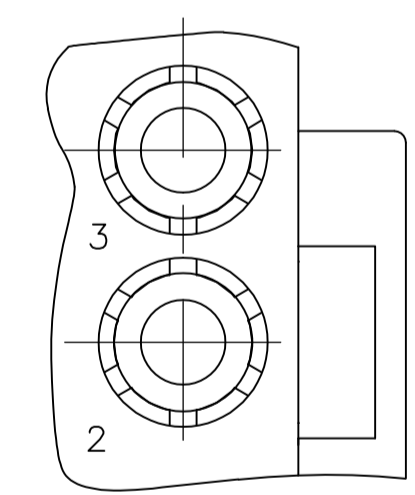
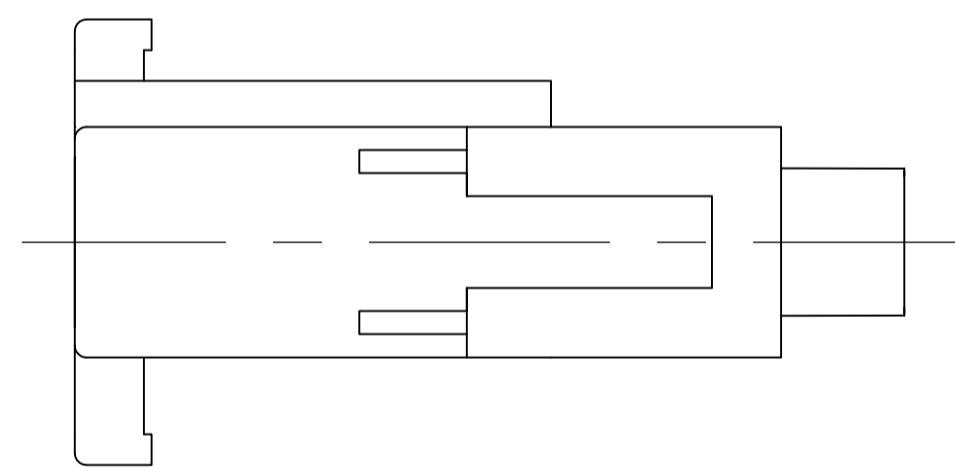

DETAIL A
OPTIONAL CONSTRUCTION

NATURAL	2029387-1
COLOR	PART NO.

THIS DRAWING IS A CONTROLLED DOCUMENT.		DIN jr_ruth 10AUG11		TE Connectivity	
DIMENSIONS: mm		CHK TOM_MICHELUTTI 10AUG11		NAME PLUG, 4 CIRCUIT, UNIVERSAL MATE-N-LOK™	
TOLERANCES UNLESS OTHERWISE SPECIFIED:		APVD TOM_MICHELUTTI 10AUG11		PRODUCT SPEC	
0. PLC ± -		APPLICATION SPEC		SIZE CAGE CODE DRAWING NO. RESTRICTED TO	
1. PLC ± -		WEIGHT		A1 00779 C=2029387	
2. PLC ± 0.20		CUSTOMER DRAWING		SCALE 4:1 SHEET 1 OF 1 REV A1	
3. PLC ± -					
4. PLC ± -					
ANGLES ± 0°30'					
MATERIAL NYLON,UL 94V-0		FINISH -			