

Features

- Zero ppm multiplication error
- Input crystal frequency range: 5 - 30MHz
- Input clock frequency range: 2 - 50MHz
- Output clock frequencies up to 200MHz
- Period jitter \leq 150ps
- 9 selectable frequencies
- Operating voltages: 3.3V \pm 10% and 5.0V \pm 10%
- Tri-state output
- Packaging (Pb-Free and Green):
 - 8-pin SOIC (W)

Description

The PI6C4511 is a high-performance frequency multiplier, that integrates analog Phase Lock Loop (PLL).

The PI6C4511 is the most cost effective way to generate a high-quality, high-frequency clock output from a crystal input or clock input. It is designed to replace crystal oscillators in electronic systems, or to be used as clock multiplier and frequency translation.

The complex logic divider generates nine different popular multiplication factors, allowing the device to produce output of many common frequencies.

The device also has an Output Enable pin that tri-states the clock output. The PI6C4511 is intended for applications that needed clock generation and frequency translation with low output jitter.

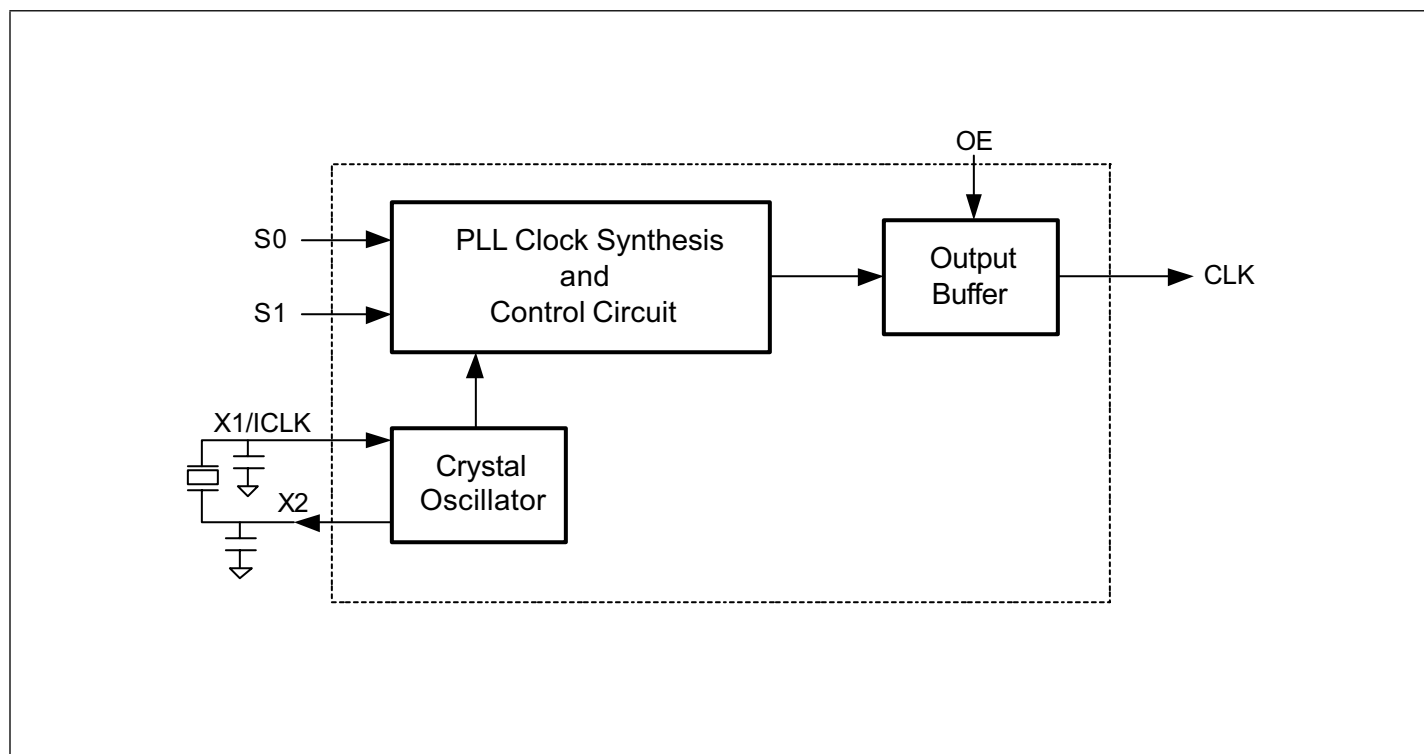
Block Diagram

Pin Diagram

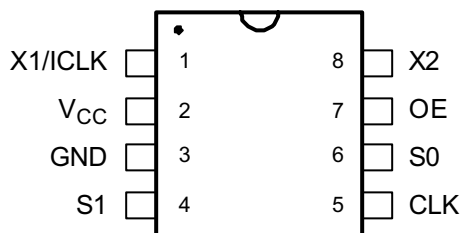

Pin Description

Pin	Name	Type	Description
1	X1/ICLK	X1	Crystal connection or clock input
2	V _{CC}	P	Supply voltage: +3V and +5V
3	GND	P	Connect to Ground
4	S1	TI	Multiplier select pin1. Connect to GND or V _{CC} or float (no connection).
5	CLK	O	Clock output per Table (see below).
6	S0	TI	Multiplier select pin 0. Connect to GND or V _{CC} or float (no connection).
7	OE	I	Output Enable. Tri-state CLK output when low. Internal pull-up
8	X2	XO	Crystal Connection. Leave unconnected for clock input

Clock Output Table

S1	S0	CLK
0	0	x4
0	M	x(16/3)
0	1	x5
M	0	x2.5
M	M	x2
M	1	x(10/3)
1	0	x6
1	M	x3
1	1	x8

M = Mid-point or float

Maximum Ratings (Above which the useful life may be impaired. For user guidelines, not tested)

Storage temperature.....	-65 to +150°C
Ambient Operating Temperature.....	0 to +70°C
Supply Voltage to Ground Potential (VCC).....	-0.3 to +7.0V
Inputs (Referenced to GND)	-0.5 to Vcc+0.5V
Clock Output (Referenced to GND).....	-0.5 to Vcc+0.5V
Soldering Temperature (Max of 10 seconds)	+260°C

Note:

Stresses greater than those listed under MAXIMUM RATINGS may cause permanent damage to the device. This is a stress rating only and functional operation of the device at these or any other conditions above those indicated in the operational sections of this specification is not implied. Exposure to absolute maximum rating conditions for extended periods may affect reliability.

Recommended Operation Conditions

Symbol	Description	Test Condition	Min.	Typ.	Max.	Units
V _{CC}	Supply Voltage		3		5.5	V
V _{IH}	HIGH Level Input Voltage		2			V
V _{IL}	LOW Level Input Voltage				0.8	V
T _A	Operating Temperature		0		+70	°C

DC Electrical Characteristics (V_{CC} = 3.3V± 10% and 5.0V± 10%, T_A= 0°C to +70°C, unless noted)

Symbol	Description	Test Condition	Pin	Min.	Typ.	Max.	Units
V _{CC}	Supply Voltage		V _{CC}	3		5.5	V
I _{CC}	Supply Current	No load, 20MHz crystal			12	20	mA
V _{IH}	Input Logic HIGH		ICLK	V _{CC} /2 +1			V
			OE	2			V
V _{IL}	Input Logic LOW		ICLK			V _{CC} /2 -1	V
			OE			0.8	V
V _{IH}	Input Logic HIGH		S0, S1	V _{CC} -0.5			V
V _{IM}	Input mid-Level				V _{CC} /2		V
V _{IL}	Input Low Level						0.5
V _{OH}	HIGH-level output voltage	I _{OH} = -12mA	CLK	2.4			V
V _{OL}	LOW-level output voltage	I _{OL} = 12mA					0.4

AC Electrical Characteristics ($V_{CC} = 3.3V \pm 10\%$ and $5.0V \pm 10\%$, $T_A = 0^\circ C$ to $+70^\circ C$, unless noted)

Sym.	Parameter	Test Condition	Pin	Min.	Typ.	Max.	Unit
F _{INX}	Input Frequency	Crystal	ICLK	5		30	MHz
F _{INC}	Input Frequency	Clock input	ICLK	2		50	MHz
F _{OUT}	Output Frequency		CLK			200	MHz
T _r	Output clock rise time	0.8 to 2.0V			1		ns
T _f	Output clock fall time	2.0 to 0.8V	CLK		1		ns
T _{DC}	Output clock duty cycle	At $V_{CC}/2$, $f \leq 150\text{MHz}$	CLK	45	50	55	%
		At $V_{CC}/2$, $150\text{MHz} \leq f \leq 200\text{MHz}$		40	50	60	
BW	PLL bandwidth			10			kHz
T _{OE}	Output enable time	OE high to output on				50	ns
T _{OT}	Output disable time	OE low to tri-state				50	
T _{PJ}	Period Jitter	70MHz to 200MHz	CLK		75	150	ps
T _{ppj}	Output Peak-to-peak Jitter	40 to 150MHz	CLK		100	300	ps

Recommended Crystal

Pericom recommends the Pericom 49S SMD series crystal, which is a low cost, low profile SMD crystal packaged in a HC-49/u short SMD package.

Recommended Crystal Specifications

Parameter	Value	Units
Mode of Oscillation	Fundamental	AT
Frequency	5 - 30	MHz
Frequency Tolerance	± 50	PPM
Temperature and Aging Stability	± 50	PPM
CO/CI Ratio	240	
Load Cap	18	pF
Equivalent Series Resistance	30	Ω

Ordering Information

<p style="text-align: center;">SEATING PLANE</p> <p style="text-align: center;">REF</p> <p style="text-align: center;">BSC</p>	<p>DOCUMENT CONTROL NO. PD - 1001</p> <hr/> <p>REVISION: F DATE: 03/09/05</p>
<p>X.XX DENOTES DIMENSIONS X.XX IN MILLIMETERS</p> <p>Notes: 1) Controlling dimensions in millimeters. 2) Ref: JEDEC MS-012D/AA</p>	<p>Pericom Semiconductor Corporation 3545 N. 1st Street, San Jose, CA 95134 1-800-435-2335 • www.pericom.com</p> <hr/> <p>DESCRIPTION: 8-Pin, 150-Mil Wide, SOIC</p> <hr/> <p>PACKAGE CODE: W</p>

Ordering Information

Ordering Code	Package Code	Package Description
PI6C4511WE	W	Pb-Free & Green 8-pin SOIC

1. Thermal characteristics can be found on the company web site at www.pericom.com/packaging/
2. E = Pb-free and Green
3. Adding an X suffix = tape/reel