

DETAIL Z  
SCALE 8:1

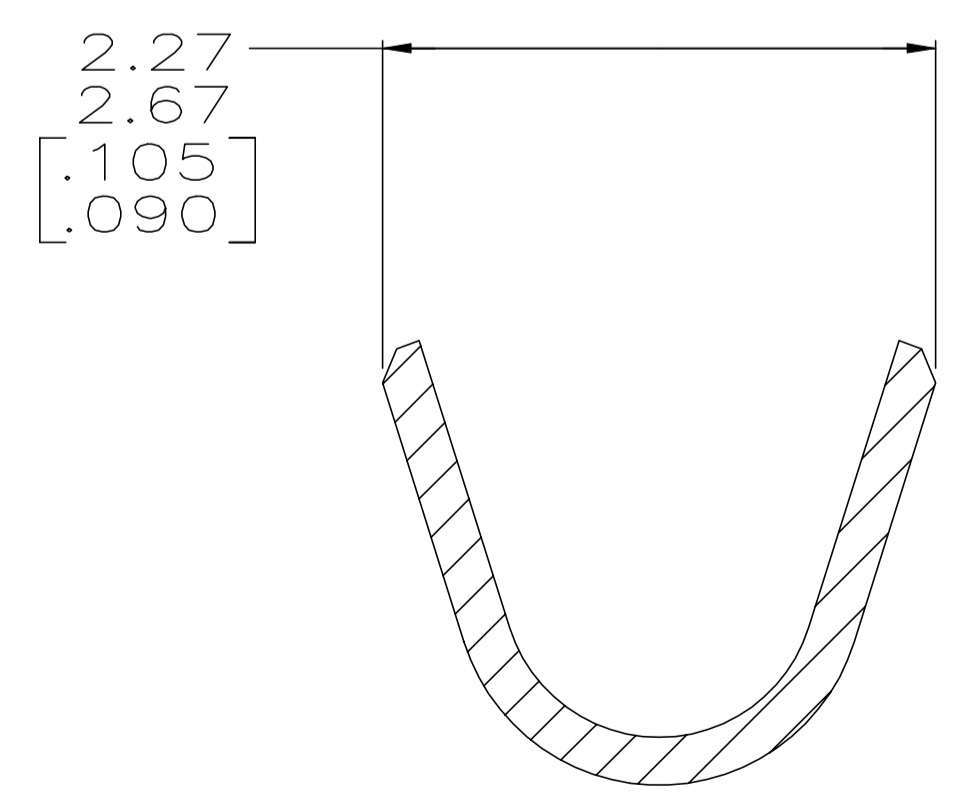

SECTION C-C  
SCALE 20:1  
INSULATION BARREL

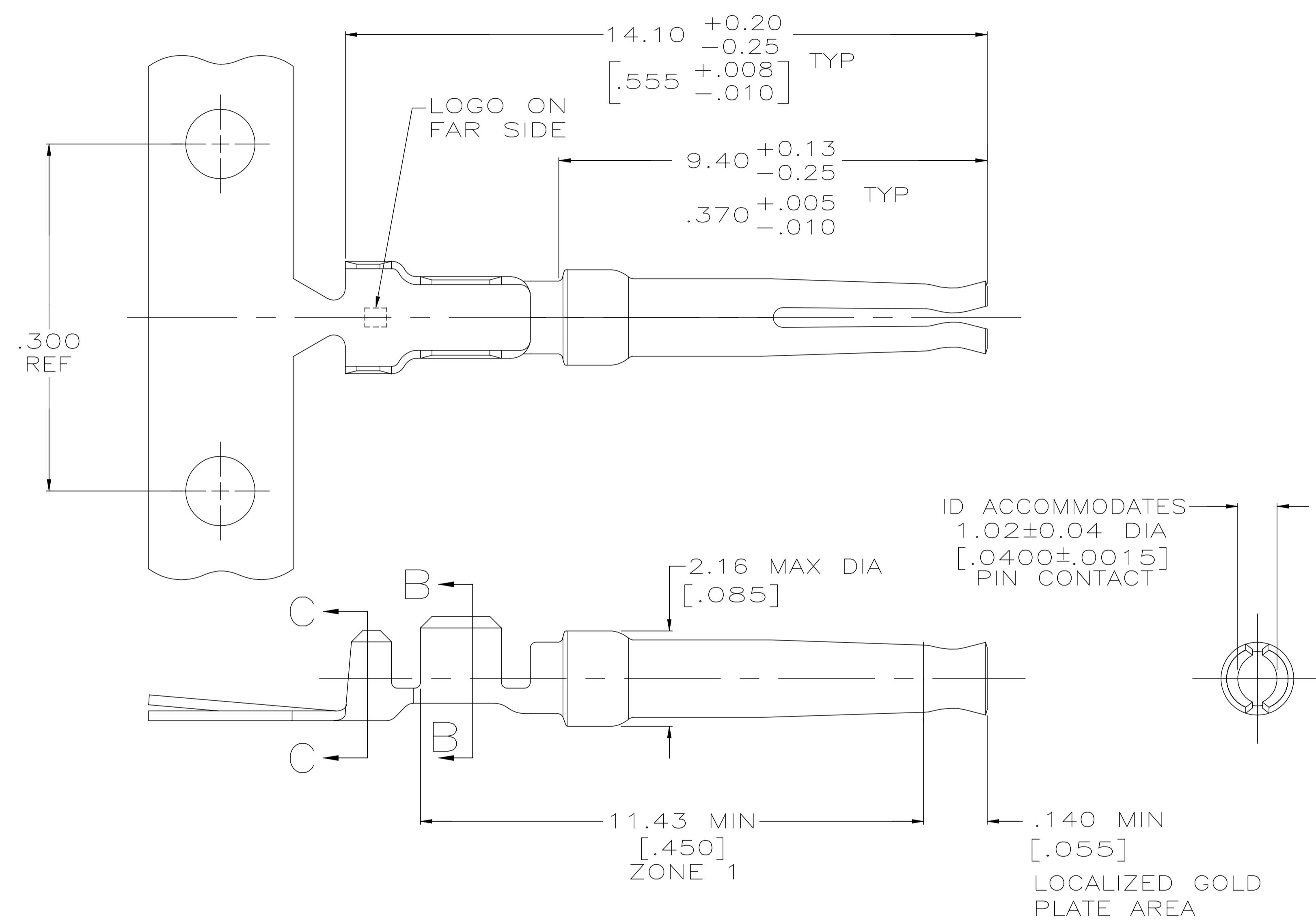
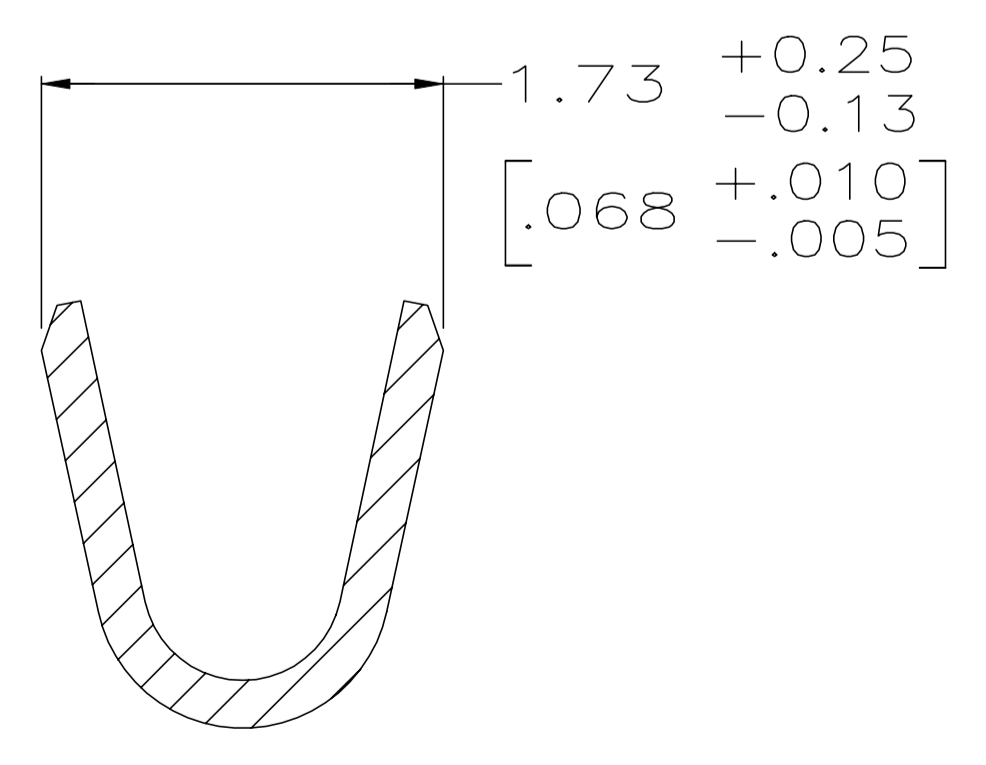

SECTION B-B  
SCALE 20:1  
WIRE BARREL

- 1 FOR MINI-APPLICATOR AND STRIPPER CRIMPER.
- 2 FOR HAND TOOL USE ONLY.
- 3 FOR STANDARD APPLICATOR PART #566171 ONLY.
- 4. WIRE RANGE OF 20-24 AWG. INSULATION RANGE OF 1.27/1.52 [.050-.060].
- 5. GOLD PLATING MAY NOT APPEAR ON CARRIER STRIP. NICKEL UNDERPLATE COVERS ENTIRE CONTACT.
- 6 GOLD PLATING PER MIL-G-45204, NICKEL PLATING PER QQ-N-290, TIN PLATING PER MIL-T-10727, COPPER PLATING PER MIL-C-14550.
- 7 PLATED WITH 1.27µm [.000050] GOLD ON INSIDE OF LOCALIZED GOLD PLATE AREA, 1.27µm [.000050] GOLD ON ZONE 1, ALL OVER 1.27µm [.000050] NICKEL UNDERPLATE.
- 8 PLATED WITH 0.76µm [.000030] GOLD ON INSIDE OF LOCALIZED GOLD PLATE AREA, GOLD FLASH ON ZONE 1, ALL OVER 1.27µm [.000050] NICKEL UNDERPLATE.  
-OR-  
GOLD FLASH OVER PALLADIUM-NICKEL 0.76µm [.000030] TOTAL ON INSIDE OF LOCALIZED GOLD PLATE AREA, GOLD FLASH ON ZONE 1, ALL OVER 1.27µm [.000050] NICKEL UNDERPLATE.
- 9 GOLD FLASH ON INSIDE OF LOCALIZED GOLD PLATE AREA, GOLD FLASH ON ZONE 1, ALL OVER 0.76µm [.000030] NICKEL UNDERPLATE.
- 10 PLATED WITH 2.54µm - 5.08µm [.000100 - .000200] TIN.
- 11 PLATED WITH 0.38µm [.000015] GOLD IN LOCALIZED GOLD PLATE AREA, GOLD FLASH ON REMAINDER, OVER 1.27µm [.000050] NICKEL.
- 12 PLATED WITH GOLD FLASH IN LOCALIZED GOLD PLATE AREA, 2.54µm [.000100] TIN PLATED WIRE BARRELS, OVER 0.76µm [.000030] NICKEL.
- 13 PLATED WITH 0.76µm [.000030] GOLD IN LOCALIZED GOLD PLATE AREA, TIN PLATED WIRE BARRELS, OVER 1.27µm [.000050] NICKEL.
- 14 AMP ITALY PART NUMBER ONLY.
- 15 PLATED WITH 1.27µm [.000050] GOLD ON INSIDE OF LOCALIZED GOLD PLATE AREA, GOLD FLASH ON ZONE 1, ALL OVER 1.27µm [.000050] NICKEL UNDERPLATE.
- 16 PLATED WITH GOLD FLASH IN LOCALIZED GOLD PLATE AREA, 0.76µm [.000030] MIN TIN PLATED WIRE BARRELS, OVER 0.76µm [.000030] MIN NICKEL.

OBSOLETE	SPECIAL	13	1	-	7-66504-4
OBSOLETE	SPECIAL	13	1	-	7-66504-3
OBSOLETE	STANDARD	16	1	-	7-66504-2
OBSOLETE	STANDARD	13	3	-	7-66504-1
	SMALL PACK	8	2	SEE DETAIL Z	7-66504-0
	STANDARD	15	1	-	6-66504-8
OBSOLETE	STANDARD	13	2	SEE DETAIL Z	6-66504-0
OBSOLETE	STANDARD	13	1	-	5-66504-9
OBSOLETE	STANDARD	12	2	SEE DETAIL Z	5-66504-7
OBSOLETE	STANDARD	12	1	-	5-66504-6
OBSOLETE	STANDARD	10	1	-	1-66504-4
	STANDARD	8	3	-	1-66504-2
	STANDARD	9	2	SEE DETAIL Z	1-66504-0
	STANDARD	8	2	SEE DETAIL Z	66504-9
	STANDARD	7	2	SEE DETAIL Z	66504-8
	STANDARD	9	1	-	66504-4
	STANDARD	8	1	-	66504-3
	STANDARD	7	1	-	66504-2
	PACKAGING TYPE				PART NUMBER

THIS DRAWING IS A CONTROLLED DOCUMENT. DIMENSIONING AND TOLERANCING PER ASME Y14.5M-2009. TO DIMENSIONS UNLESS OTHERWISE SPECIFIED:

0 PLC	±	-
1 PLC	±	-
2 PLC	±	0.13 [005]
3 PLC	±	-
4 PLC	±	-
ANGLES	±	-

MATERIAL: PHOSPHOR BRONZE PER QQ-B-750

FINISH: SEE TABLE

APPROVED: J. ASSINI

DATE: 3-28-90

NAME: J. ASSINI

PRODUCT SPEC: SOCKET CONTACT, SIZE 20 DF, 20-24 AWG, AMPLIMITE

APPLICATION SPEC: -

SIZE: A1

CAGE CODE: 00779

DRAWING NO: 66504

RESTRICTED TO: -

CUSTOMER DRAWING

SCALE: 15:1

SHEET: 1 OF 1

REV: AR