

AT89STK-09 Starter Kit for AT83C26

.....

User Guide





Section 1

Introduction	1-2
1.1 Acronyms	1-2
1.2 Features	1-2

Section 2

Hardware	2-6
2.1 Power Supply	2-6
2.2 Jumper Configuration	2-6
2.3 Host Microcontroller Connection	2-6
2.4 Test points	2-9

Section 3

Quick Start	3-12
3.1 Smart cards Insertion	3-12
3.2 Layout	3-13

Section 4

Schematics & Bill Of Material	4-14
4.1 Bill Of Material	4-18



Section 1

Introduction

This document helps the user to get started with the AT89STK09 starter kit.

The AT89STK09 is a starter kit for the AT83C26 device. The AT83C26 is a smart card reader interface with 2 DC/DC converters allowing to manage up to 5 smart cards including level shifters. This device needs TWI commands to configure its registers. This device requires a host microcontroller (Smart Card Reader Microcontrollers, ARMs, ...) with one or two ISO7816 Smart Card Interfaces.

Refer to the AT83C26 datasheet for further product information.

1.1 Acronyms

- TWI : Inter Integrated Circuit
- SCIB: Smart Card Interface Bus
- LDO : Low Drop Output (Regulator)

1.2 Features

The AT89STK-09 Board provides the following features:

- AT89STK09 board with 2 ISO7816-3 connectors and 4 SIM/SAM connectors
- 2 Gemplus GemClub Smart cards
- One 20 multicolor wires cable with HE10 connector
- Smart Card Reader IC CDR0M (from may 2005)
- 2 VQFP48 & 2 QFN48 samples
- AT89STK09 user guide document

The AT89STK09 board allows a large number of hardware configurations.

Figure 1-1. AT89STK09 board

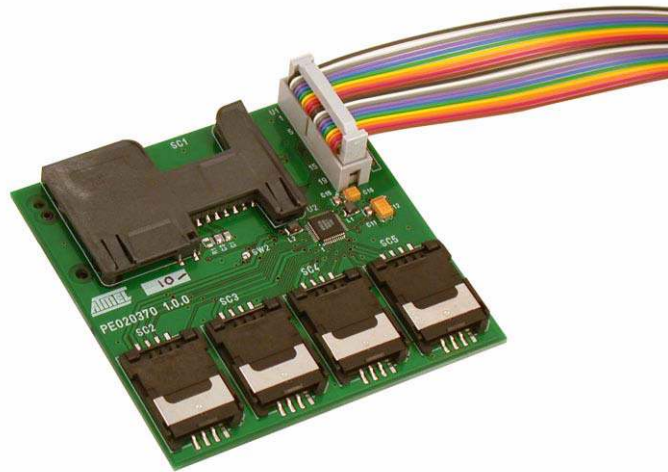
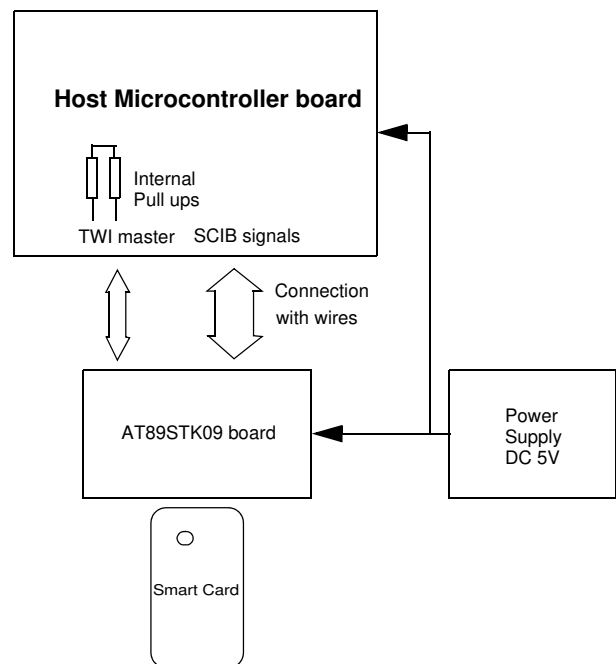

Figure 1-1 describes a possible hardware configuration with:

- Same power supply voltage for AT89STK09 board and host microcontroller board
- TWI master signals from a host microcontroller board
- SCIB signals connected to AT89STK09 board
- Smart card clock from host microcontroller board

Figure 1-2. Configuration Description





Section 2

Hardware

The AT89STK09 requires power supply, clock signal, smart card and TWI commands to run. U1 connector is used to connect the AT83C26 host pins to the host microcontroller. The U1 connector pins are described on Table 2-1.

All passive components needed (inductors, capacitors) are soldered on board.

-
- 2.1 Power Supply** The host microcontroller signals voltage and the AT83C26 power supply are VCC. The voltage range (VCC) is 3V to 5.5V, the maximum current consumption I_{VCC} is about 250mA when all DC/DC convertors and LDO are activated. (Conditions : $V_{CC} = 3V$ 60mA DC/DCa, 70mA DC/DCb).
-
- 2.2 Jumper Configuration** The AT83C26 board has one jumper in order to set complete SC2 configuration. The complete SC2 configuration (Smart Card including CC4 & CC8) is done by SW1 solder pad.
-
- 2.3 Host Microcontroller Connection** The host microcontroller must provide the signals:
- VCC, VSS : Power supply signals - 3 - 5.5V @ 250mA
 - EVCC can be used when the Vcc host and Vcc are different. Generally the EVCC is connected to VCC.
 - BYPASS is used to activate the low power consumption when connected to the host microcontroller (high level must be supplied) - Generally the BYPASS is connected to the ground.
 - A2, A1 : TWI address - Generally A2 = 0 and A1 = 0 during Reset
 - SDA, SCL : TWI signals to transmit/receive commands/status
- Caution : TWI pull-ups have to be on the host microcontroller board*
- CLK signal is connected to host clock signal
- Caution : The logic inverter (HC04 or other) is recommended if source clock is supplied by output crystal oscillator buffer.*
- \overline{INT} (Interrupt) : This signal must be connected to host interrupt input
 - CRST signal is connected to RST host microcontroller signal
 - CCLK signal is connected to the host smart card interface signal

- IO1, IO2, AUX1 and AUX2 are connected to the host smart card interface signals depending on the configuration chosen. (Refer to the datasheet AT83C26)

Table 2-1. U1 Description

#	Name	Color
1	CCLK	Brown
2	$\overline{\text{INT}}$	Red
3	CRST	Orange
4	Not Connected	Yellow
5	VSS	Green
6	CLK	Blue
7	VSS	Velvet
8	Not Connected	Grey
9	AUX2	Blank
10	$\overline{\text{RESET}}$	Black

#1	Name	Color
11	AUX1	Brown
12	Not Connected	Red
13	IO2	Orange
14	BY PASS	Yellow
15	IO1	Green
16	VSS	Blue
17	SCL	Velvet
18	VCC	Grey
19	SDA	Blank
20	EVCC	Black

2.3.1 CPRES0 & 1 External Pullups

R1(component side), R2 (solder side) can be added if internal CPRES0, CPRES1 pull up are not activated. R1, R2 recommended values are between 27KOhms to 1MOhms. By default, resistors value is 180KOhms

Figure 2-1. AT89STK09 board

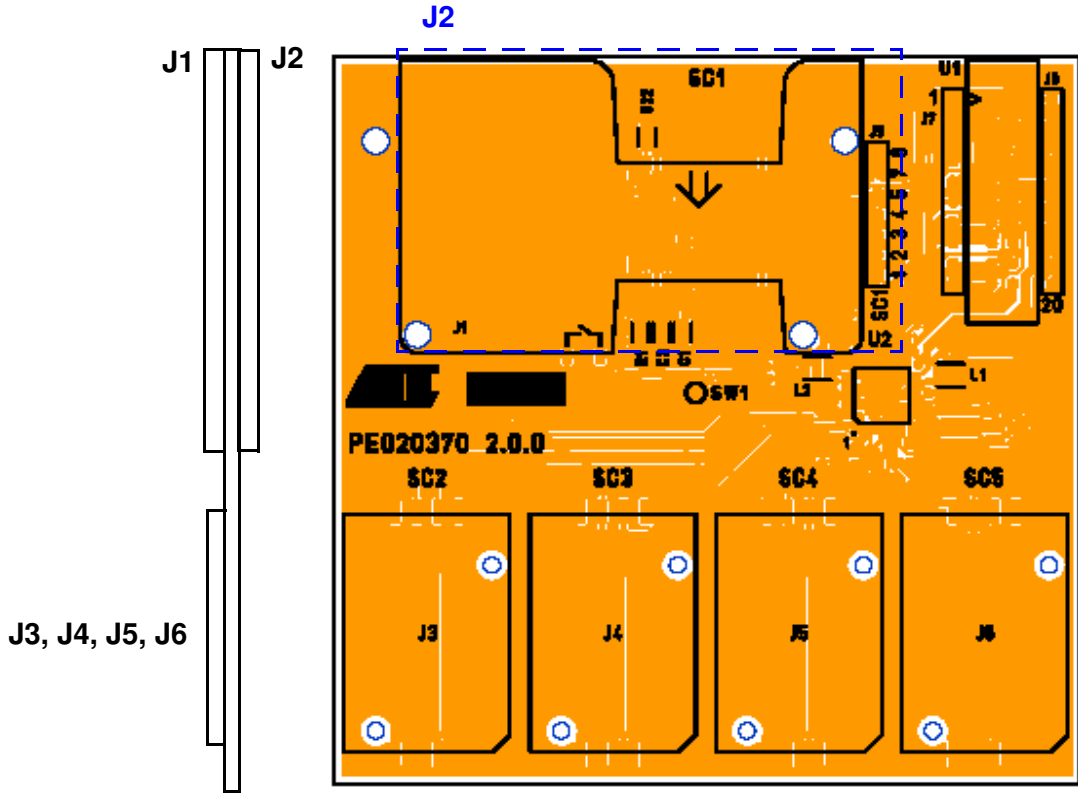

2.4 Test Points

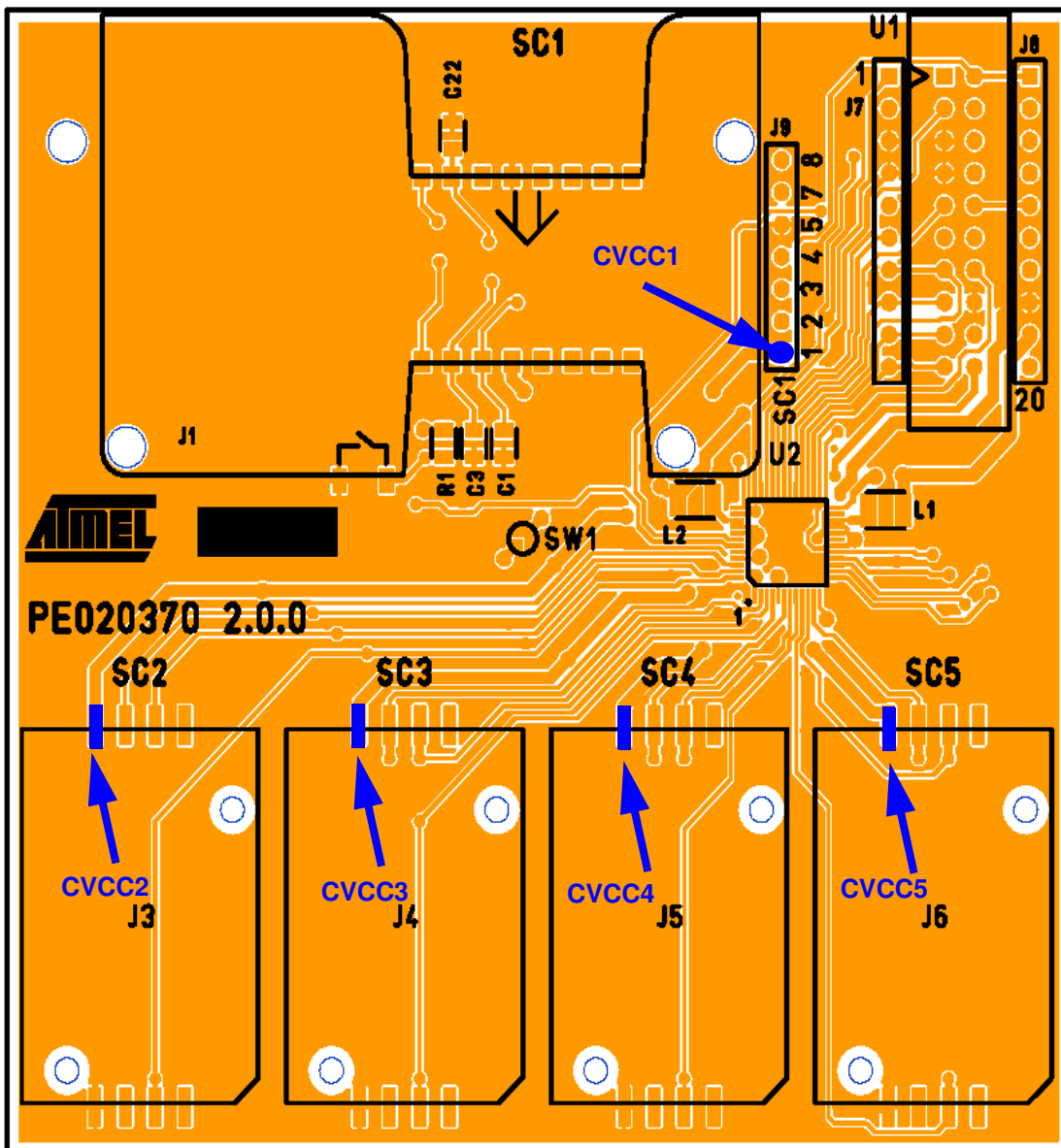

Caution : Active probe use is recommended to measure all smart card interfaces signals

Signal	
DC/DCB	

Section 3

Quick Start

3.1 Smart cards Insertion

Be careful with the direction of the smart cards in the connector.

Figure 3-1. Smart Card Direction

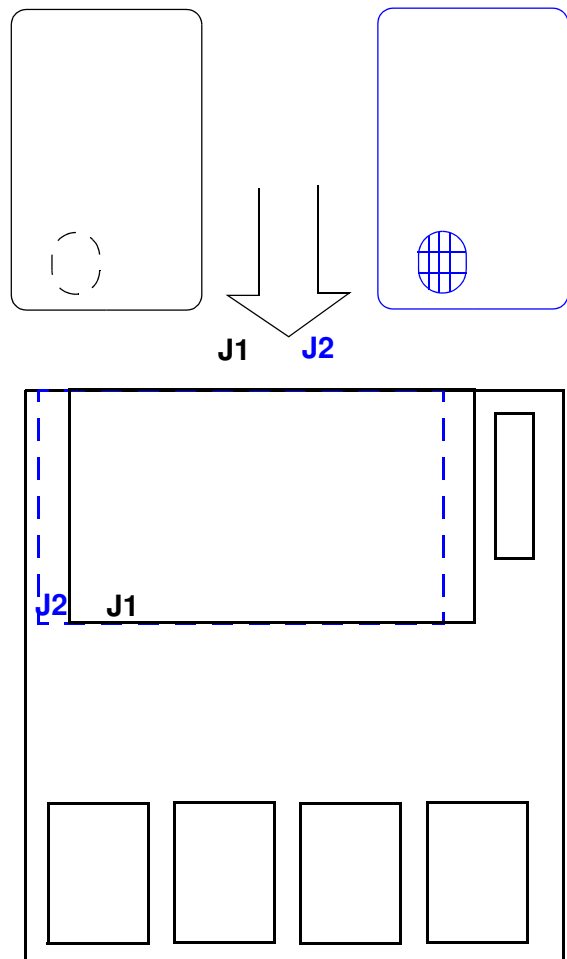

3.2 Layout

The board layout has been optimized in order to reduce the noise, overshoot & undershoot on the smart card interface signals. The board is used to pass EMV certification level 1. Gerber file is available on demand at cardreader@atmel.com

Figure 3-2. Component & Solder Sides

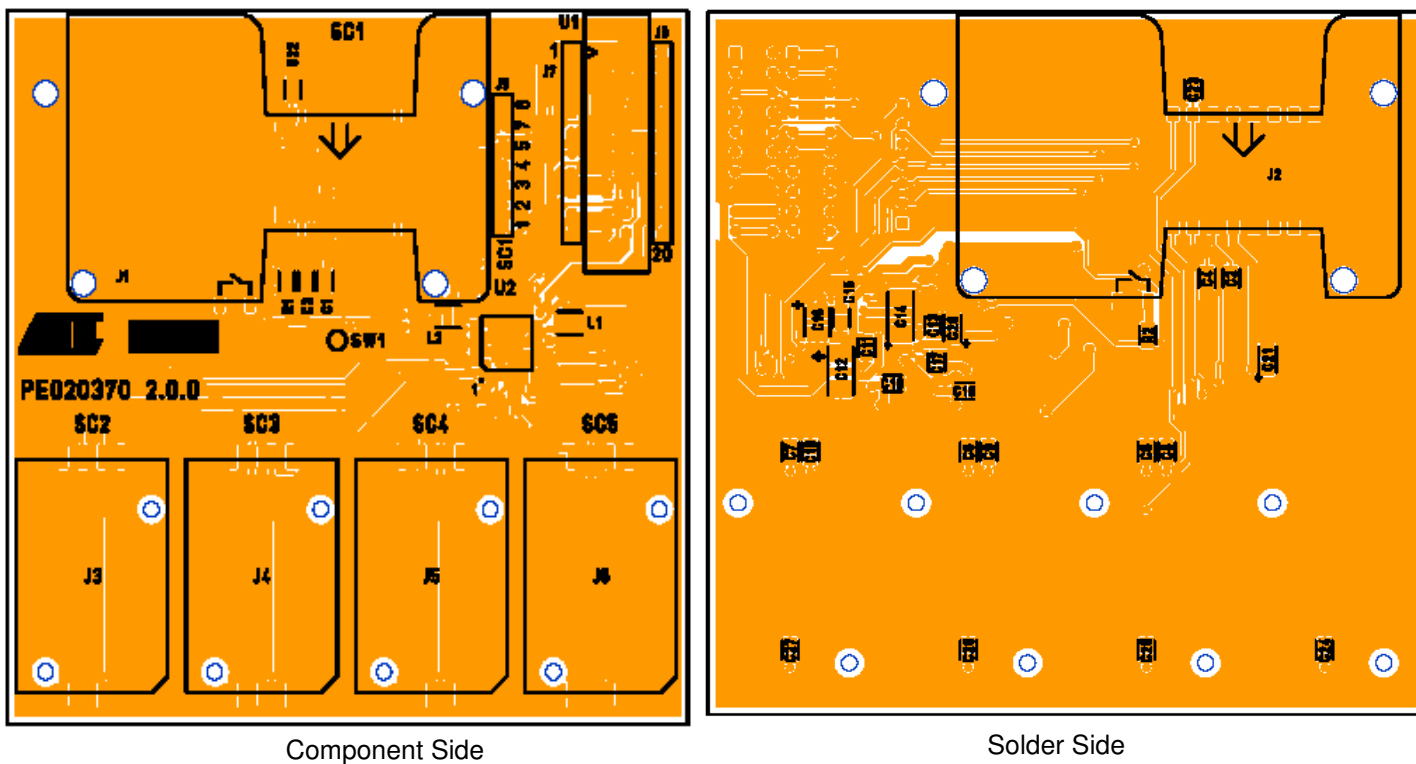

Section 4

Schematics & Bill Of Material

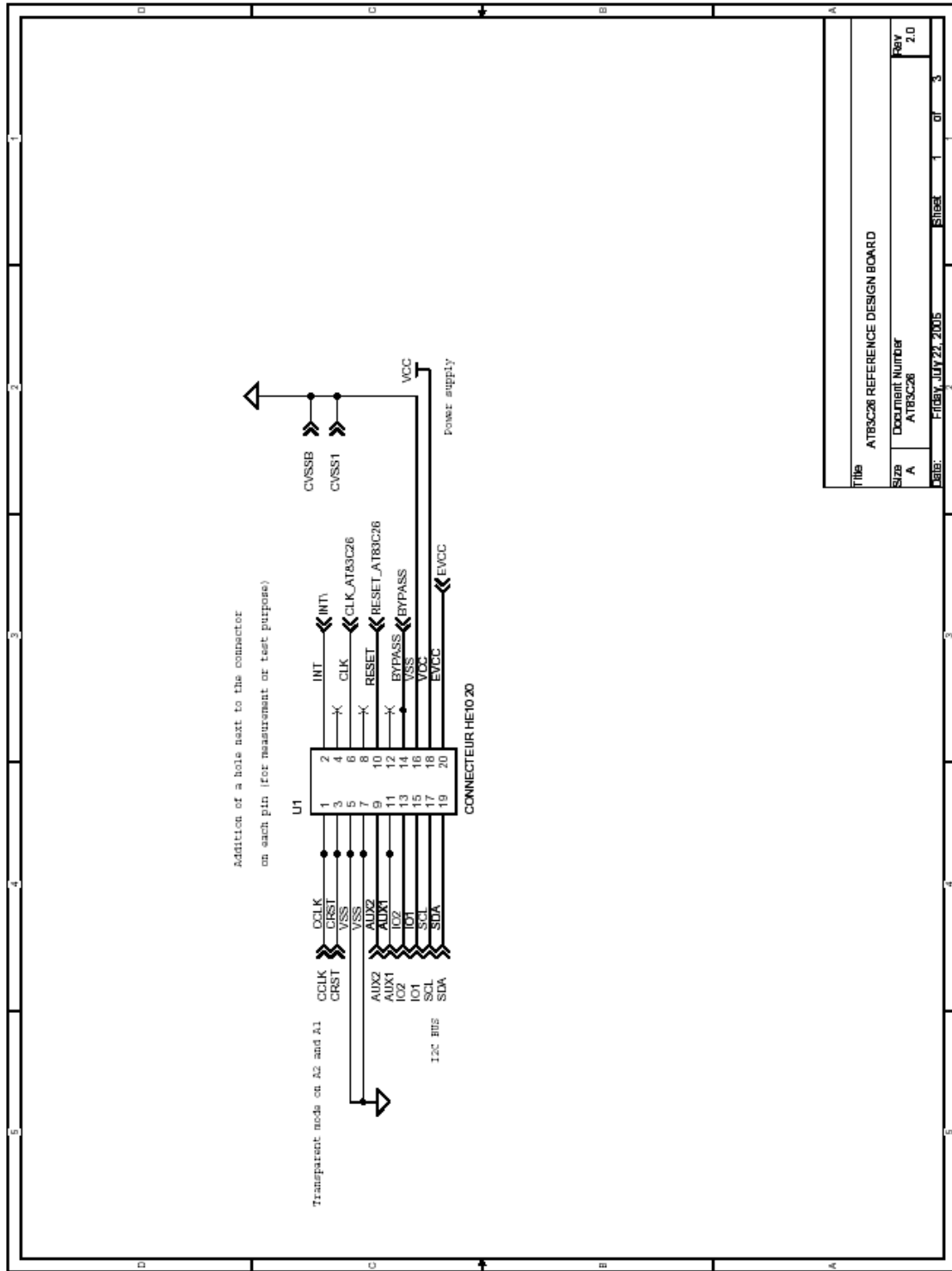

Title		AT89C26 REFERENCE DESIGN BOARD	
Size	Document Number	Rev	
A	AT89C26	2.0	
Date:	File	July 22, 2005	Sheet 1 of 3



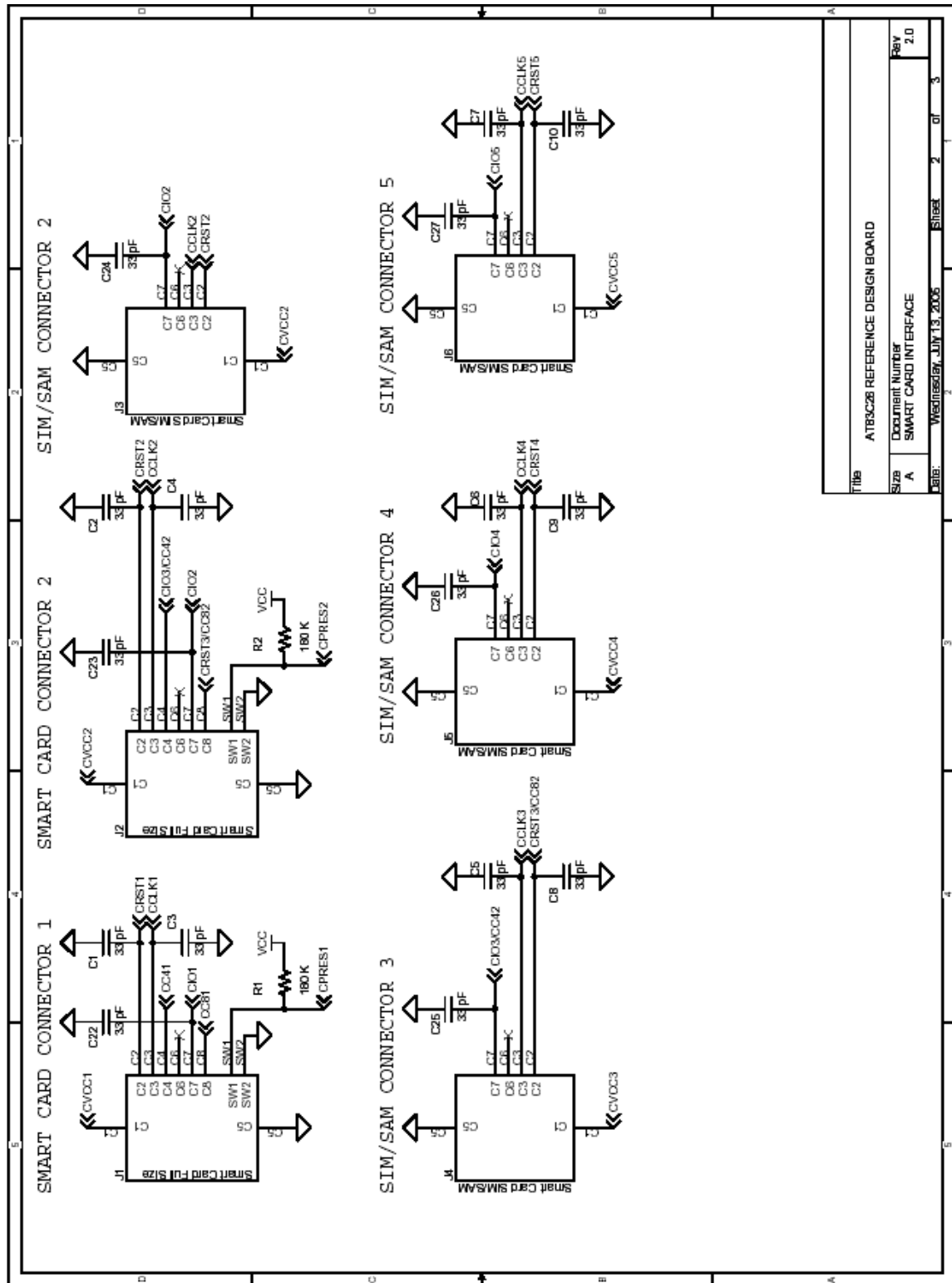

Title		AT89C26 REFERENCE DESIGN BOARD	
Size		DOCUMENT NUMBER	
A		SMART CARD INTERFACE	
Date		Wednesday, July 13, 2005	
Sheet		2 of 3	
Rev		2.0	

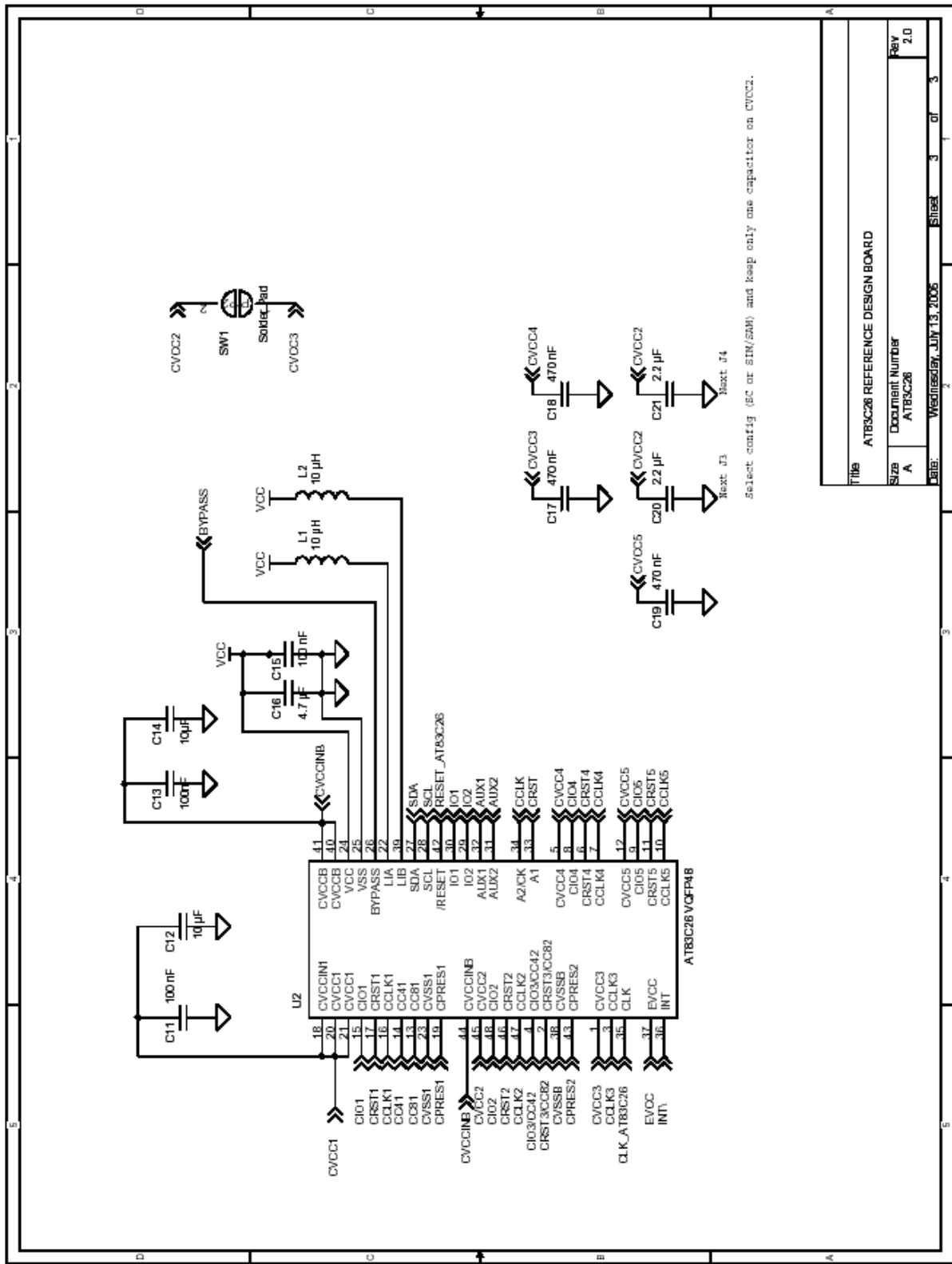

THIS AT89C26 REFERENCE DESIGN BOARD	
Size	Document Number
A	AT89C26
Date:	Wednesday, July 13, 2005
Sheet	3 of 3
Rev	2.0

4.1 Bill Of Material

Reference	Part	Description	Manufacturer Ref
C1,C2,C3,C4,C5,C6, C7, C8, C9, C10, C22, C23, C24, C25, C26, C27	33 pF	50V-5% Ceramic Capacitor	
C11,C13, C15	100 nF	50V-5% Ceramic	
C14	10 μ F		
C20,C21	2.2 μ F		
C17,C18,C19	470 nF	16V-10%-Ceramic	
C16	4.7 μ F		
C12	10 μ F	16V +/-20%	
R1,R2	180 KOhms	1/16W-5%	
L1,L2	10 μ H	10% Inductance 300 mA SMD	MURATA LQH32CN100K21L or LQH32CN100K11L or LQH32CN100K01L
U2	AT83C26	VQFP48	



Atmel Corporation

2325 Orchard Parkway
San Jose, CA 95131, USA
Tel: 1(408) 441-0311
Fax: 1(408) 487-2600

Regional Headquarters

Europe

Atmel Sarl
Route des Arsenalux 41
Case Postale 80
CH-1705 Fribourg
Switzerland
Tel: (41) 26-426-5555
Fax: (41) 26-426-5500

Asia

Room 1219
Chinachem Golden Plaza
77 Mody Road Tsimshatsui
East Kowloon
Hong Kong
Tel: (852) 2721-9778
Fax: (852) 2722-1369

Japan

9F, Tonetsu Shinkawa Bldg.
1-24-8 Shinkawa
Chuo-ku, Tokyo 104-0033
Japan
Tel: (81) 3-3523-3551
Fax: (81) 3-3523-7581

Atmel Operations

Memory

2325 Orchard Parkway
San Jose, CA 95131, USA
Tel: 1(408) 441-0311
Fax: 1(408) 436-4314

Microcontrollers

2325 Orchard Parkway
San Jose, CA 95131, USA
Tel: 1(408) 441-0311
Fax: 1(408) 436-4314

La Chantrerie
BP 70602
44306 Nantes Cedex 3, France
Tel: (33) 2-40-18-18-18
Fax: (33) 2-40-18-19-60

ASIC/ASSP/Smart Cards

Zone Industrielle
13106 Rousset Cedex, France
Tel: (33) 4-42-53-60-00
Fax: (33) 4-42-53-60-01

1150 East Cheyenne Mtn. Blvd.
Colorado Springs, CO 80906, USA
Tel: 1(719) 576-3300
Fax: 1(719) 540-1759

Scottish Enterprise Technology Park
Maxwell Building
East Kilbride G75 0QR, Scotland
Tel: (44) 1355-803-000
Fax: (44) 1355-242-743

RF/Automotive

Theresienstrasse 2
Postfach 3535
74025 Heilbronn, Germany
Tel: (49) 71-31-67-0
Fax: (49) 71-31-67-2340

1150 East Cheyenne Mtn. Blvd.
Colorado Springs, CO 80906, USA
Tel: 1(719) 576-3300
Fax: 1(719) 540-1759

Biometrics/Imaging/Hi-Rel MPU/ High Speed Converters/RF Datacom

Avenue de Rochepleine
BP 123
38521 Saint-Egreve Cedex, France
Tel: (33) 4-76-58-30-00
Fax: (33) 4-76-58-34-80

Literature Requests

www.atmel.com/literature

Disclaimer: Atmel Corporation makes no warranty for the use of its products, other than those expressly contained in the Company's standard warranty which is detailed in Atmel's Terms and Conditions located on the Company's web site. The Company assumes no responsibility for any errors which may appear in this document, reserves the right to change devices or specifications detailed herein at any time without notice, and does not make any commitment to update the information contained herein. No licenses to patents or other intellectual property of Atmel are granted by the Company in connection with the sale of Atmel products, expressly or by implication. Atmel's products are not authorized for use as critical components in life support devices or systems.

© Atmel Corporation 2005. All rights reserved. Atmel® and combinations thereof are the trademarks of Atmel Corporation or its subsidiaries. Other terms and product names may be the trademarks of others.



Printed on recycled paper.