

LOC	DIST	REVISIONS			
P	LTR	DESCRIPTION	DATE	DWN	APVD
	B	REVISED PER ECO-15-007451	30JUN2015	JA	DM
	C	REVISED PER PCN E-18-010846	25JUL2018	SM	DM
	C1	REVISED PER PCN-22-149104	10AUG2022	JT	IG

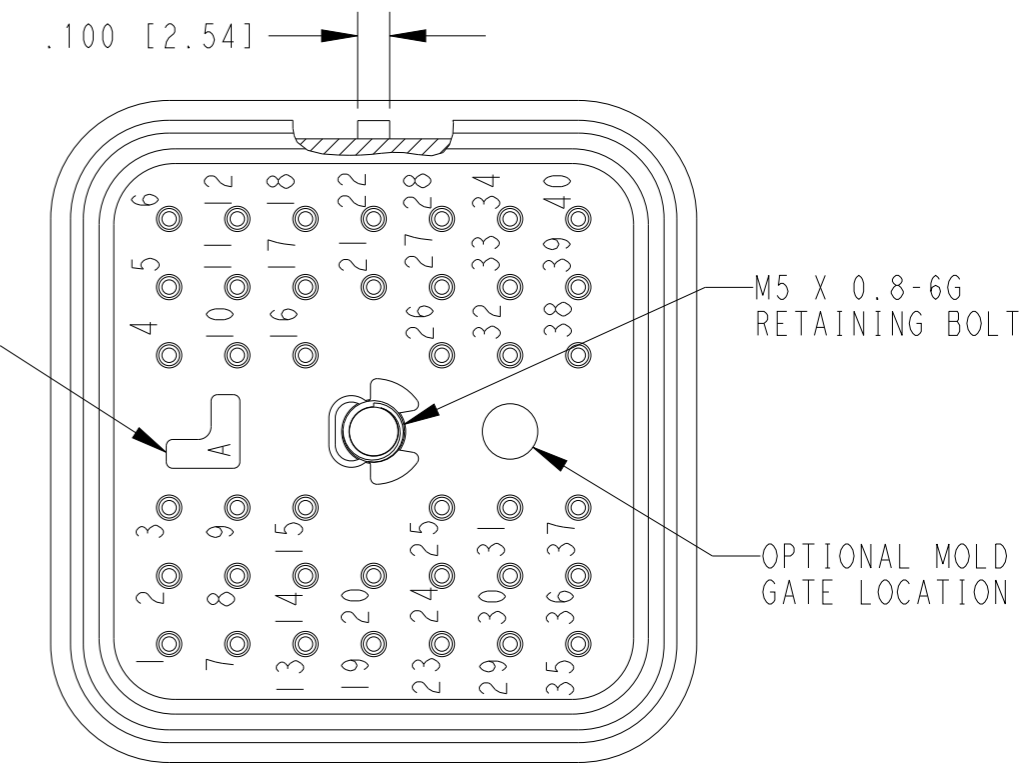
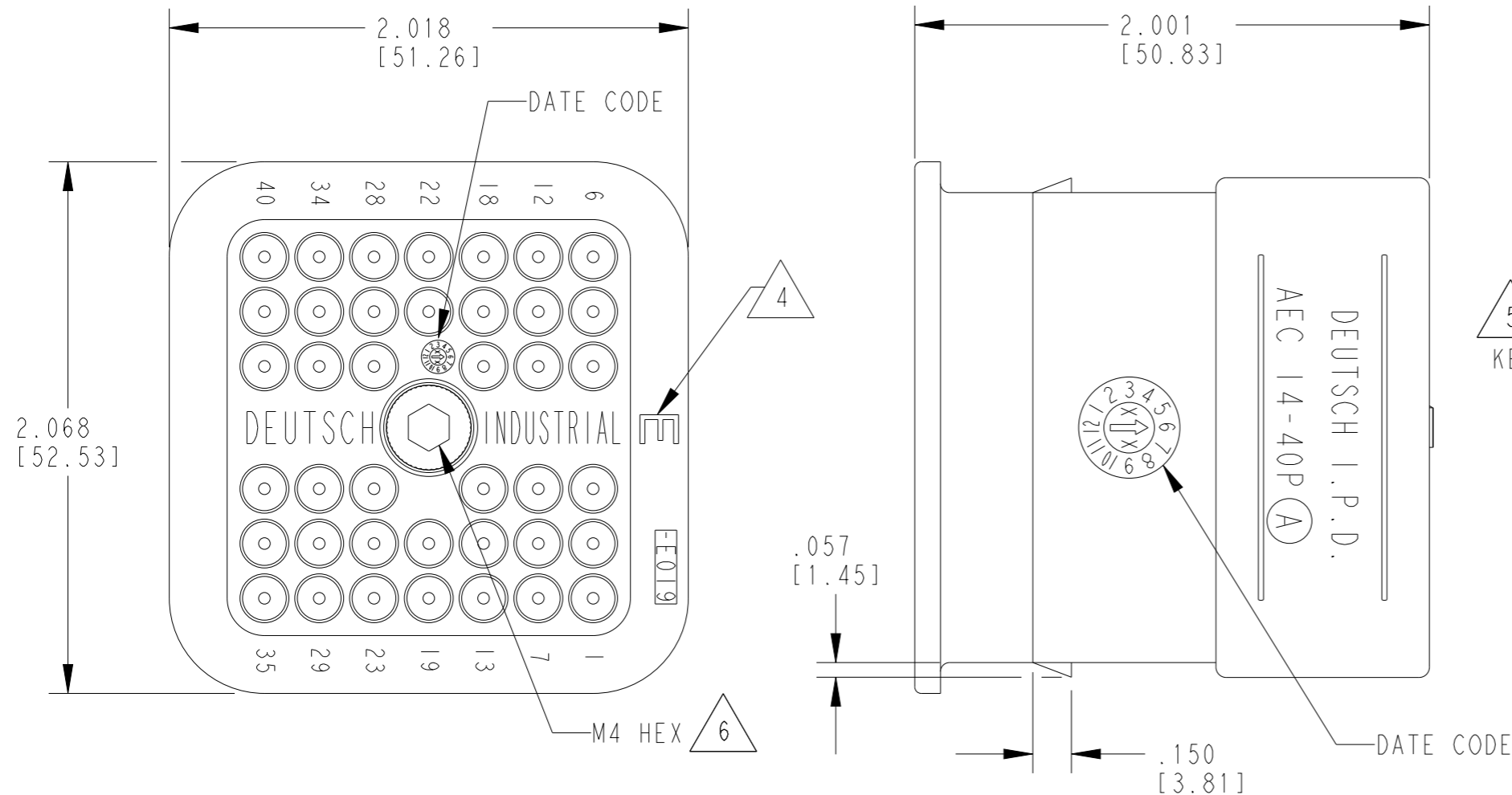

MIN. INSUL. OD [mm]	MAX. INSUL. OD [mm]	WIRE RANGE [mm ²] REF ONLY
.053 [1.346]	.120 [3.048]	14-20 AWG [2.0-0.50]

- 6 MATING TORQUE REQUIREMENT: 25-28 IN-LB [2.82-3.16 Nm].
- 5 SEE SHEET 2 FOR OTHER KEY ARRANGEMENTS.
- 4 'E' SEAL IDENTIFIED BY LETTER "E" MARK.
- 3 MATERIAL: RECEPTACLE: PEI GF 30% (BLACK)
 SEAL/GROMMET: VMQ (RED-ORANGE)
 BOLT: STAINLESS STEEL WITH SILVER PLATED AND MAY TARNISH.
 CLIP: STEEL, UNPLATED.

2. THIS RECEPTACLE MATES WITH AEC16-40SX-XXXX; AEC18-40SX-XXXX AND AEC16-40SU PLUGS. (X=A,B,C,D,U KEYS; XXXX=ALL MODIFICATIONS). CONSULT FACTORY FOR MODS.

1. RECEPTACLE IS SUPPLIED WITH DUST CAP. (0515-009-4005).

NOTES: UNLESS OTHERWISE SPECIFIED

TE INTERNAL PN	DEUTSCH PN	THEORETICAL WEIGHT
AEC14-40PAE-E019	AEC14-40PAE-E019	103.89g
AEC14-40PBE-E019	AEC14-40PBE-E019	
AEC14-40PCE-E019	AEC14-40PCE-E019	
AEC14-40PDE-E019	AEC14-40PDE-E019	
AEC14-40PABE-E019	AEC14-40PABE-E019	103.77g
AEC14-40PCDE-E019	AEC14-40PCDE-E019	

THIS DRAWING IS A CONTROLLED DOCUMENT.		DWN 04FEB2008 JAIME C. APOSTOL	TE Connectivity	
DIMENSIONS: INCHES [mm]		CHK 14AUG2008 BRICE BYFORD		
TOLERANCES UNLESS OTHERWISE SPECIFIED:		APVD 11AUG2008 DAVID MEYER	NAME RECEPTACLE, 40 SIZE 16 KEYS A,B,C,D,AB,CD E-SEAL -E019 MOD, AEC SERIES	
0 PLC ± 1 PLC ± 2 PLC ± 3 PLC ±.025 [0.64] 4 PLC ± ANGLES ± FINISH ±		PRODUCT SPEC 0425-015-0000	SIZE A3	CAGE CODE 4AFU8
MATERIAL 3		APPLICATION SPEC	DRAWING NO AEC14-40PXXE-E019	RESTRICTED TO -
		WEIGHT SEE TABLE	SCALE 5:3	SHEET 1 OF 2
		Customer Drawing	REV C1	

LOC	DIST	REVISIONS					
		P	LTR	DESCRIPTION	DATE	DWN	APVD
		-		SEE SHEET 1	-	-	-

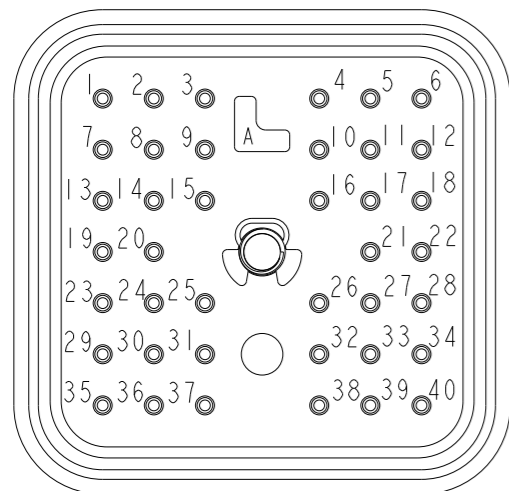

AEC14-40PAE-E019
KEY 'A'

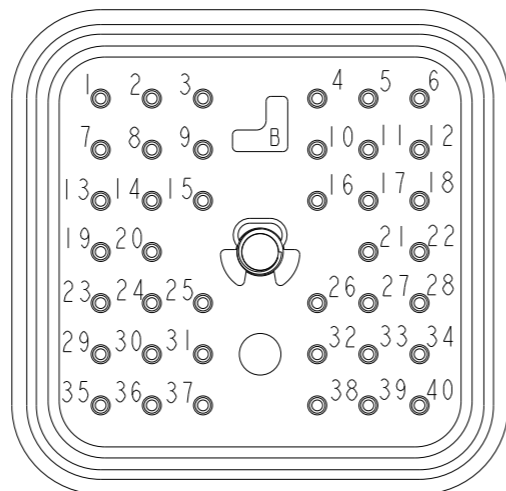

AEC14-40PBE-E019
KEY 'B'

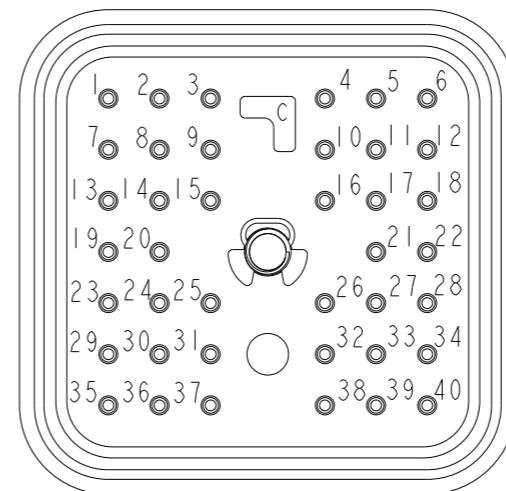

AEC14-40PCE-E019
KEY 'C'

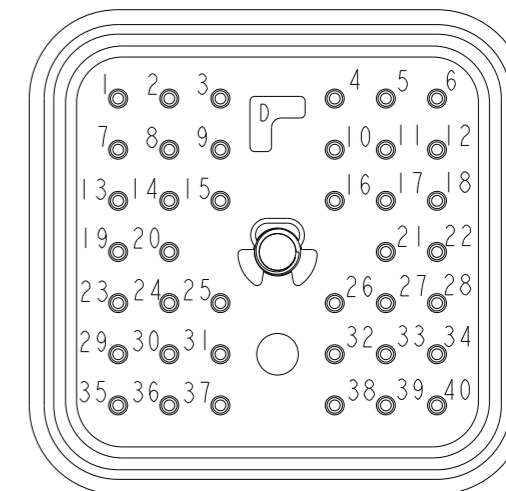

AEC14-40PDE-E019
KEY 'D'

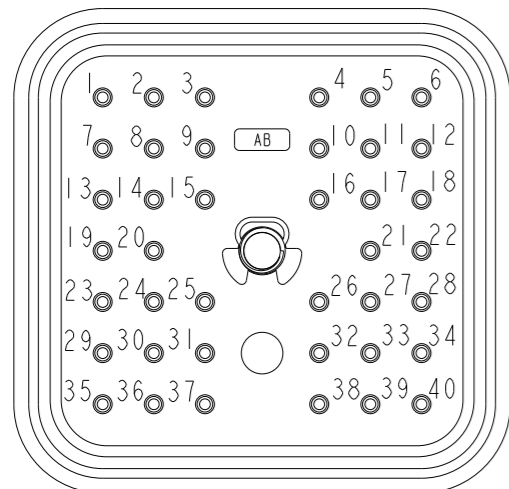

AEC14-40PABE-E019
KEY 'AB'

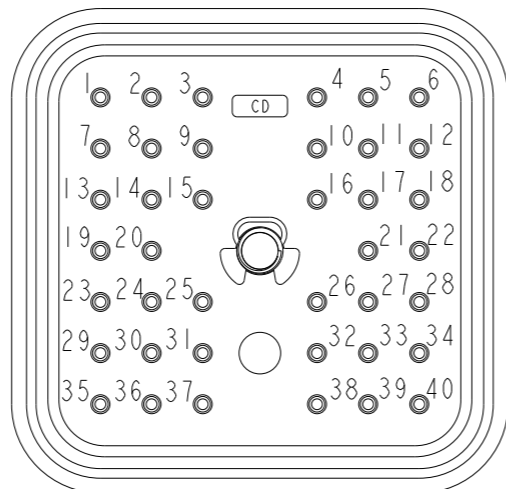

AEC14-40PCDE-E019
KEY 'CD'

THIS DRAWING IS A CONTROLLED DOCUMENT.		DWN JAIME C. APOSTOL 04FEB2008				
DIMENSIONS: INCHES [mm]		CHK BRICE BYFORD 14AUG2008				
TOLERANCES UNLESS OTHERWISE SPECIFIED:		APVD DAVID MEYER 11AUG2008	NAME RECEPTACLE, 40 SIZE 16 KEYS A,B,C,D,AB,CD E-SEAL -E019 MOD, AEC SERIES			
<ul style="list-style-type: none"> 0 PLC ± 1 PLC ± 2 PLC ± 3 PLC ±.025 [0.64] 4 PLC ± ANGLES ± FINISH 		PRODUCT SPEC 0425-015-0000	SIZE A3	CAGE CODE 4AFU8	DRAWING NO AEC14-40PXXE-E019	RESTRICTED TO -
MATERIAL 3		APPLICATION SPEC	SCALE 5:4		SHEET 2 OF 2	REV C1
		WEIGHT	Customer Drawing			