

35 W dimmable single string LED driver using HVLED001A and STF10LN80K5

Data brief



Features

- Input voltage: $V_{IN} = 90 - 305 V_{rms}$,
f: 45 - 66 Hz
- Output current: 700 mA
($V_{LED} = 24 V$ to 48 V)
- Dimming: 100% to 10%
- Dimming interfaces: 0 - 10 V and PWM input
- High power factor, low THD
- Efficiency: > 90% @ full load
- Open load voltage limiting (52.4 V)
- Optional remote turn-off input
- Optional 3.3 V – 0.1 A voltage regulator
- Fast V_{OUT} discharge
- RoHS compliant

Description

The STEVAL-ILL070V4 is intended to drive one LED string with a maximum output current of 700 mA. The LED current can be finely adjusted using either a 0 - 10 V interface or a PWM signal (for example, provided by a microcontroller) on the SELV portion of the board.

The universal input capability makes this board suitable in worldwide designs.

On the secondary side, the board includes a connector to plug an auxiliary linear on the switching voltage regulator side to supply small circuits (e.g., IoT wireless expansions like BLE, Spirit or WiFi modules). The schematic for a simple linear regulator to supply 5 V or 3.3 V is also provided.

A very high power factor and efficiency are obtained even at light loads. Input voltage variations, excessive input voltage (overvoltage like surges or bursts) and very low input voltages are managed by the HVLED001A protections, improving the reliability of the application.

The output capacitor is automatically discharged at turn-off to prevent any harm from contact with output connector.

Output open circuit and overload protections include auto restart for safe operation in lighting environments.

1 Board description

Figure 1: Jumper and connector locations

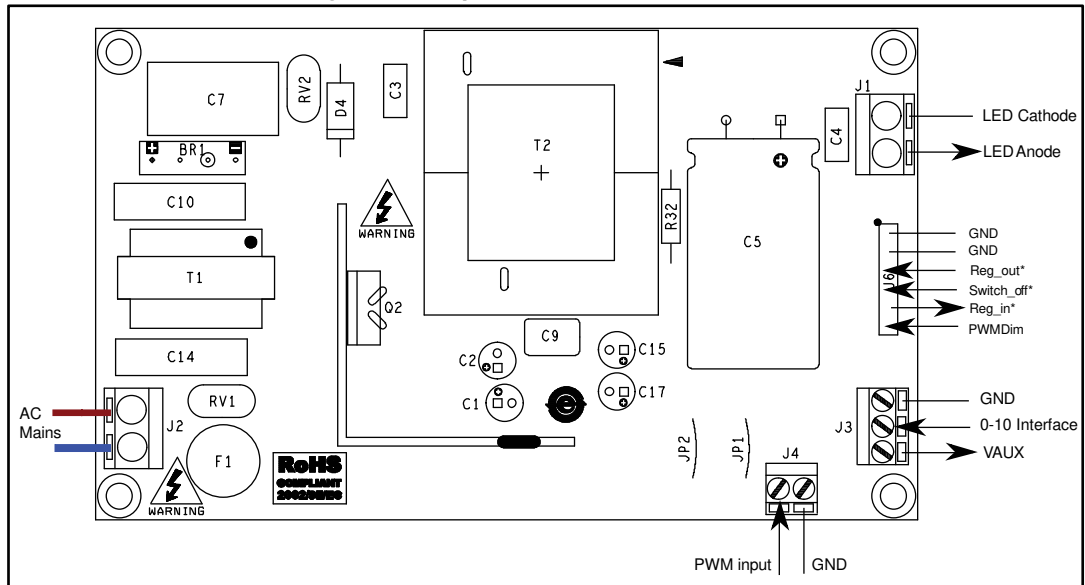

Table 1: Description of the jumper and connector signals

Con	Pin	Signal name	Dir	Description and use
J1	1	LED Cathode	Output	Connect to the cathode of the LED string
	2	LED Anode	Output	Connect to the anode of the LED string
J2	1	AC mains	Input	First connection to AC Mains – Warning high voltage
	2	AC mains	Input	First connection to AC Mains – Warning high voltage
J3	1	AUX	Output	Regulated 12 V signal with 2mA capability – suitable to supply a variable resistor to drive 0 - 10 V interface
	2	0-10 Interface	Input	A voltage between this pin and GND sets the level of output current: 10 V sets the maximum I _{OUT} while any voltage between 1 V and 0 V sets the minimum current
	3	GND	Ground	Secondary side signal reference voltage
J4	1	GND	Ground	Secondary side signal reference voltage
	2	PWM Input	Input	A PWM signal applied to this terminal sets an output current proportional to signal's duty cycle. The recommended PWM signal amplitude is between 3.3 V and 5 V. The recommended PWM signal frequency is between 200 Hz (especially when U6 is used, see Figure 3 for reference) and 1 kHz (especially when original configuration is used).
J6	1	GND	Ground	Secondary side signal reference voltage
	2	GND	Ground	Secondary side signal reference voltage
	3	Reg_out	Input	Output of the optional external Voltage regulator (not provided)

Con	Pin	Signal name	Dir	Description and use
	4	Switch_off	Input	Set this pin to 3.3 V to turn off the LED string. Set to 0 V or left open during normal operation
	5	Reg_in	Output	Unregulated output to supply the optional external Voltage regulator (not provided). Assemble R49 (0R0) to activate this function
	6	PWM_dim	Input	Same as J4, 2 (PWM Input)

2 Schematic diagrams

Figure 2: STEVAL-ILL070V4 – schematic of constant current regulation section

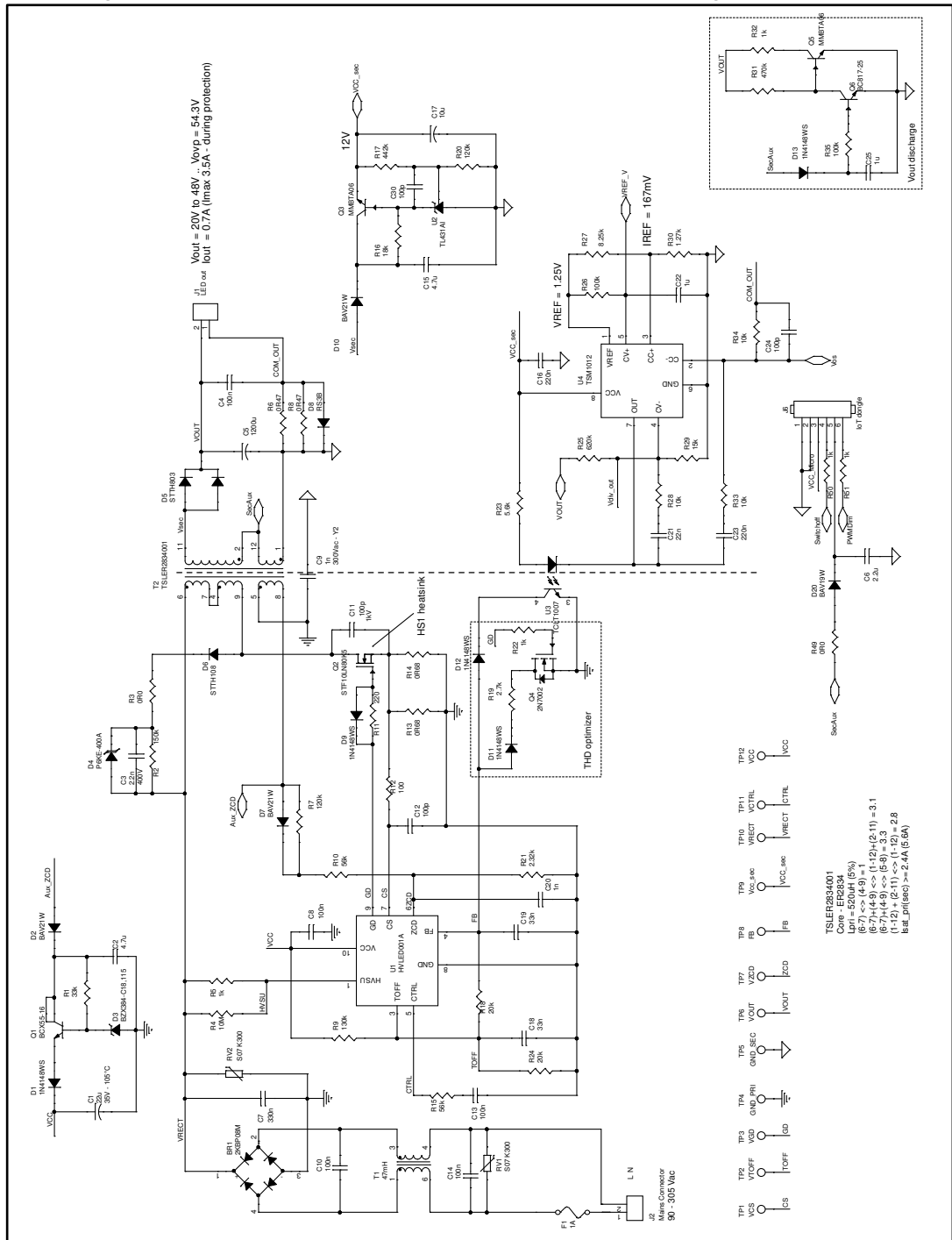
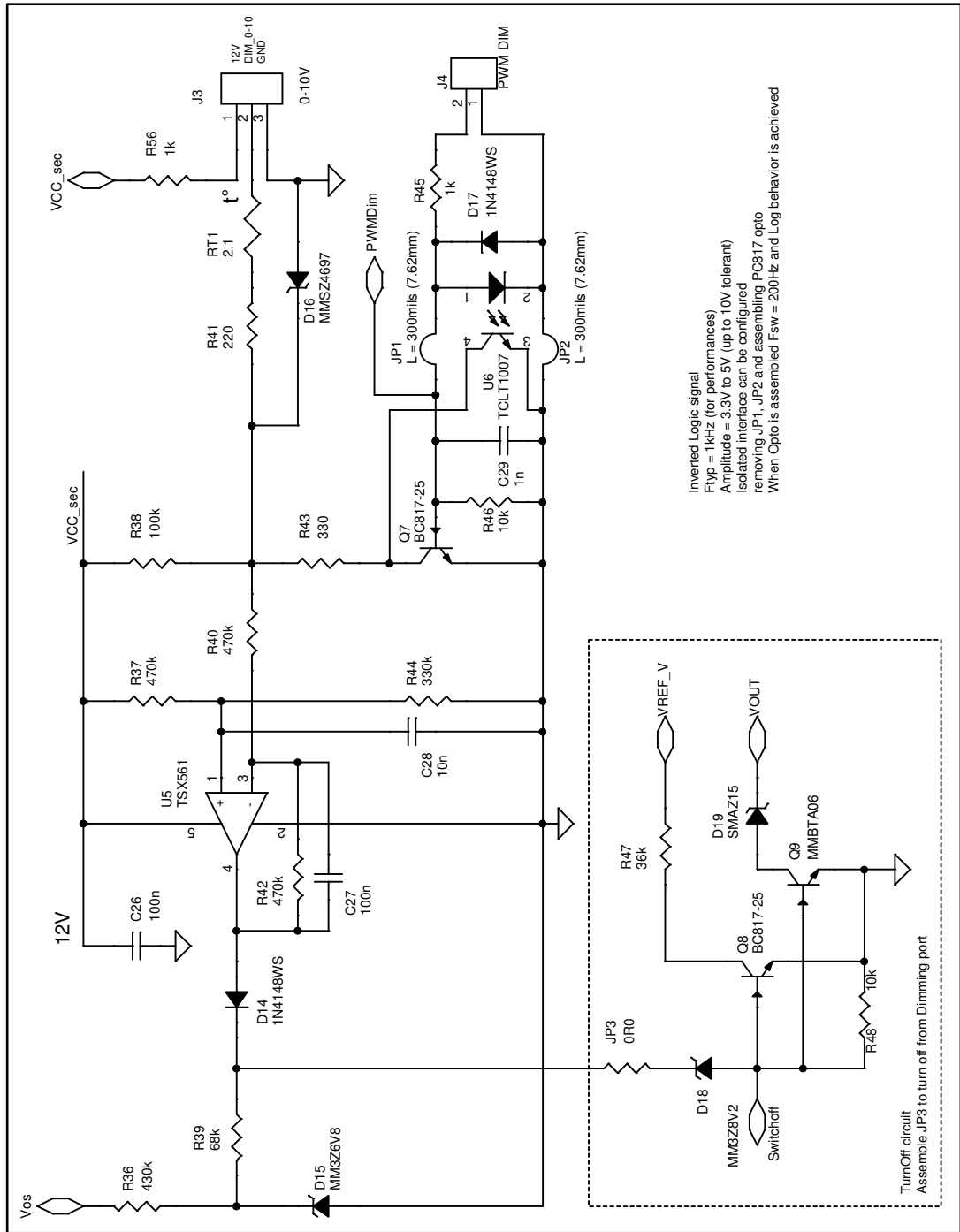

Figure 3: STEVAL-ILL070V4 – schematic of dimming interface section



3 Revision history

Table 2: Document revision history

Date	Version	Changes
03-Oct-2017	1	Initial release.

IMPORTANT NOTICE – PLEASE READ CAREFULLY

STMicroelectronics NV and its subsidiaries ("ST") reserve the right to make changes, corrections, enhancements, modifications, and improvements to ST products and/or to this document at any time without notice. Purchasers should obtain the latest relevant information on ST products before placing orders. ST products are sold pursuant to ST's terms and conditions of sale in place at the time of order acknowledgement.

Purchasers are solely responsible for the choice, selection, and use of ST products and ST assumes no liability for application assistance or the design of Purchasers' products.

No license, express or implied, to any intellectual property right is granted by ST herein.

Resale of ST products with provisions different from the information set forth herein shall void any warranty granted by ST for such product.

ST and the ST logo are trademarks of ST. All other product or service names are the property of their respective owners.

Information in this document supersedes and replaces information previously supplied in any prior versions of this document.

© 2017 STMicroelectronics – All rights reserved