

© 1963 BY AMP INCORPORATED. ALL RIGHTS RESERVED. AMP PRODUCTS COVERED BY PATENTS AND/OR PATENTS PENDING. APPROVED PER GOVT CONTRACT NO.

REVISIONS				
ZONE	LTR	DESCRIPTION	DATE	APPROVED
✓	P	REVISED PER 0600-3683-95 TA	10-95	/WARNER

CAVITY IDENTIFICATION ON P/N (1)-582551-1 ONLY.

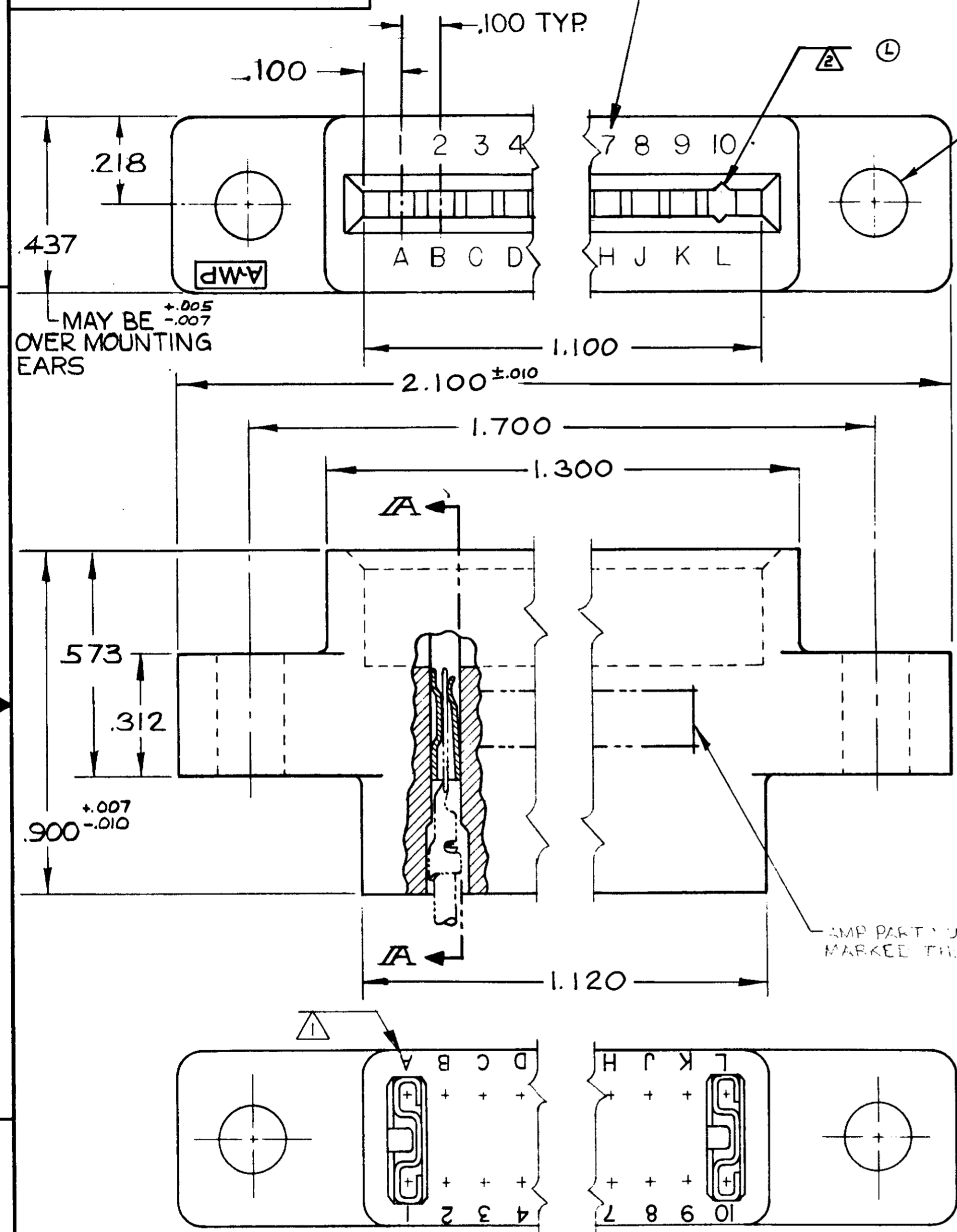

obs. 582551-2 1. SAME AS -1 EXCEPT. 2. "J" DIA. HOLES = .128

(1)-582551-1 1. SAME AS -1 EXCEPT TO HAVE CAVITY IDENTIFICATION ON TOP SURFACE OF HOUSING.

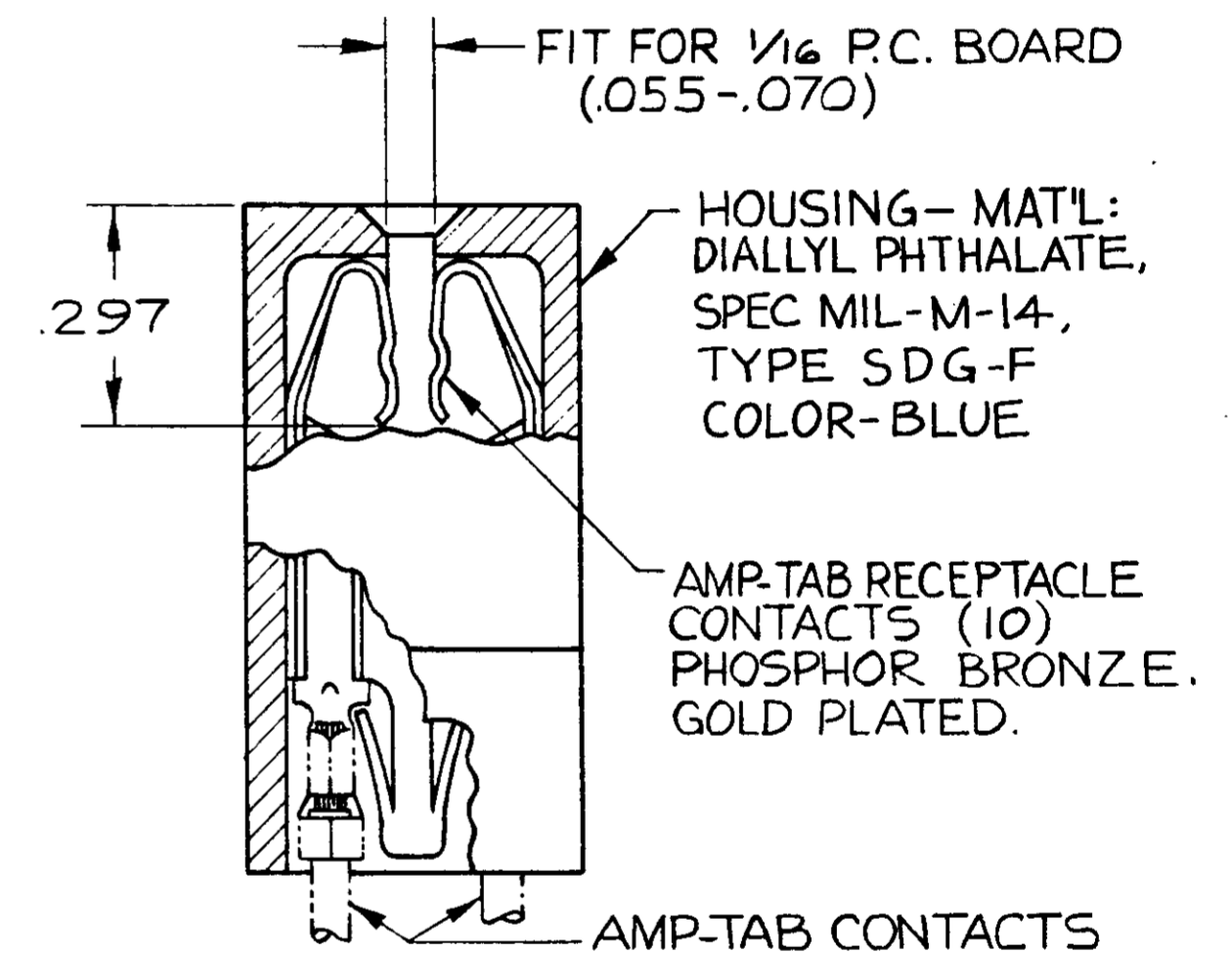

SECTION A-A

NOTE:
 ① UPPER CASE LETTERS, OMIT LETTERS G, I, O & Q. CIRCUIT CAVITY IDENTIFICATION MARKING PER MIL-C-21097.
 ② GROOVES FOR "ON CONTACT KEYING" AMP'S OPTION DEPENDING ON METHOD OF MANUFACTURE. FOR "ON CONTACT" KEYING USE KEYING PLUG P/N 583487-1 (MUST BE ORDERED SEPARATELY).

UNLESS OTHERWISE SPECIFIED DIMENSIONS ARE IN INCHES TOLERANCES ON		CONTRACT NO.		AMP INCORPORATED HARRISBURG, PENNSYLVANIA	
FRACTIONS ±	DECIMALS ± .005	ANGLES ±	DR <i>J. acid</i>	DATE 6-7-67	AMP TRADEMARK
MATERIAL	SEE CALLOUT		CHK <i>S. H. ...</i>	DATE 11/16/67	
HEAT TREAT	SEE CALLOUT		DSGN ENGR	DATE	NAME 10 POSITION AMP-TAB CONNECTOR .100 CENTERS DUAL
FINISH	SEE CALLOUT		APPD	DATE	
OTHER APPD			OTHER APPD		SIZE C
SCALE 4-1			CODE IDENT NO 00779	NUMBER 582551	WT
			CALL		ACTUAL
					SHEET

NUMBER CUS. 582551