

REVISIONS				
P	LTR	DESCRIPTION	DATE	APP'D
M		REVISED PER ECO-16-001548	24FEB2016	AP DG

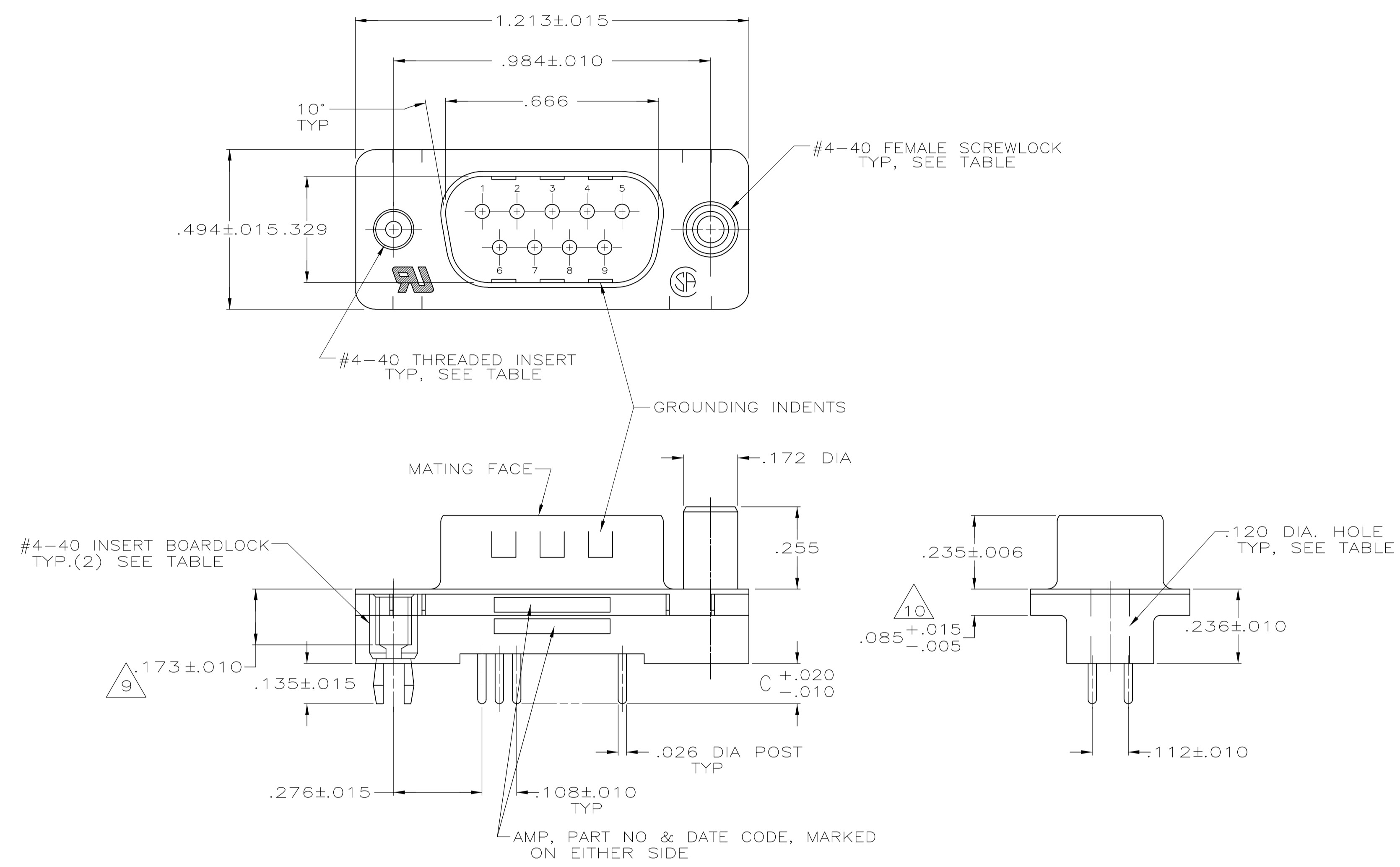

- △ HOUSING: FLAME RETARDANT 94V-0 RATED THERMOPLASTIC, BLACK
SHELLS: CARBON STEEL
CONTACTS: BRASS
INSERTS AND RETENTION INSERTS: BRASS
SCREWLOCKS: ZINC
- △ SHELLS: .000200 MIN TIN OVER .000100 MIN COPPER.
INSERTS: UNPLATED.
RETENTION INSERTS: .00150 MIN TIN-LEAD OVER .000100 MIN COPPER.
SCREWLOCKS: UNPLATED.
CONTACTS: SEE TABLE.
- △ GOLD FLASH FOR A LENGTH OF .150 MIN FROM MATING END, .000100-.000200 BRIGHT TIN OR BRIGHT TIN-LEAD ON SOLDER END, ALL OVER .000050 MIN NICKEL ON ENTIRE CONTACT.
- △ GOLD PLATED FOR A LENGTH OF .150 FROM MATING END, .000030 MIN GOLD IN MATED AREA, .000100-.000200 BRIGHT TIN OR BRIGHT TIN-LEAD ON SOLDER END, ALL OVER .000050 MIN NICKEL ON ENTIRE CONTACT.
-OR-
GOLD FLASH OVER PALLADIUM NICKEL PLATED FOR LENGTH OF .150 FROM MATING END, .000030 MIN PALLADIUM NICKEL IN MATED AREA, .000100-.000200 BRIGHT TIN OR BRIGHT TIN-LEAD ON SOLDER END, ALL OVER .000050 MIN NICKEL ON ENTIRE CONTACT.
- 5. NOTE DELETED.
- △ VERSION AVAILABLE UPON REQUEST.
- △ OBSOLETE PART NUMBER.
- △ DATUMS AND BASIC DIMENSIONS ESTABLISHED BY CUSTOMERS.
- △ RECOMMENDED SCREWLOCK IS 5747877-3 WITH RETENTION INSERTS.
- △ .110 MAX IN SHELL TAB CLINCH AREAS.

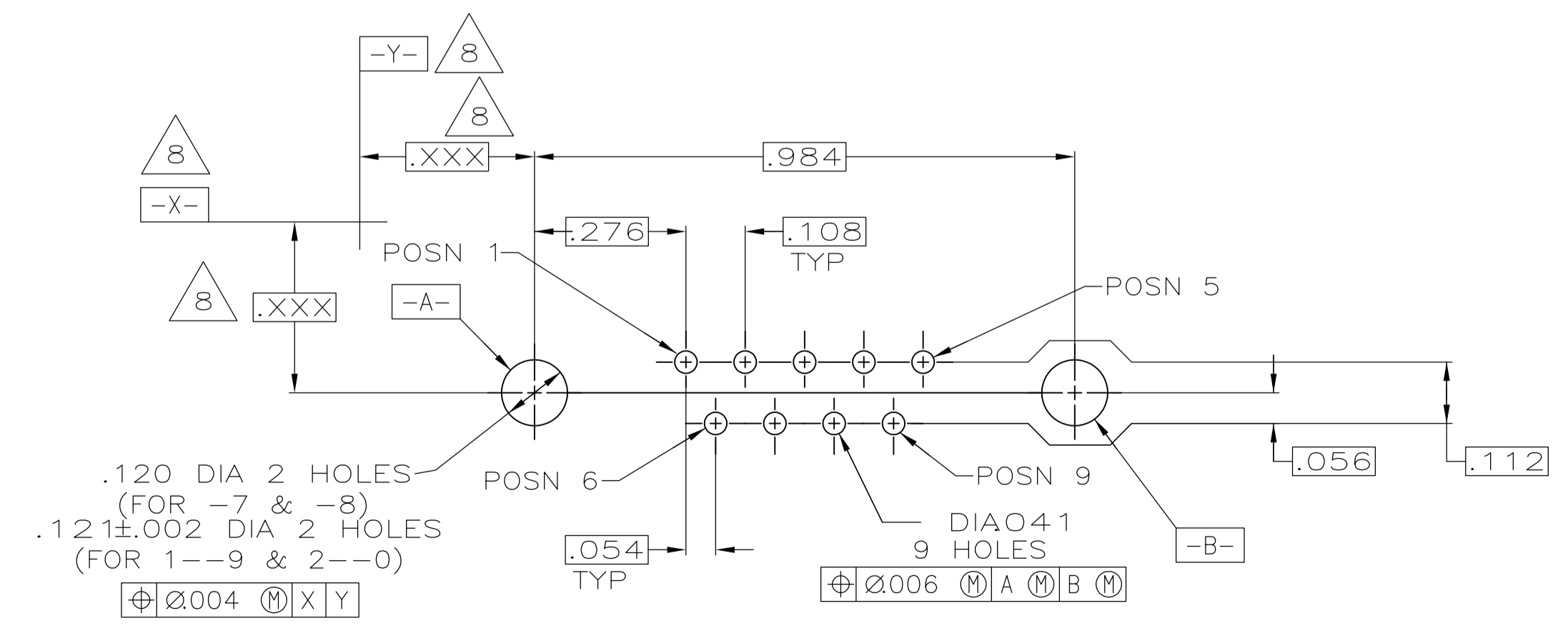

PC BOARD MOUNTING DIMENSIONS
CONNECTOR SIDE OF BOARD
.062 PC BOARD THICKNESS

WITH	RETENTION INSERTS	△	.125	2-748003-0
SUPSD BY 2-748003-0		△	.125	1-748003-9
WITH FEMALE SCREWLOCKS		△	.250	△
		△	.250	△
		△	.170	△
		△	.170	△
		△	.125	△
WITH THREADED INSERTS		△	.250	△
		△	.170	△
		△	.170	△
		△	.125	748003-8
		△	.125	△ 748003-7
WITH .120 DIA. HOLE		△	.250	△
		△	.250	△
		△	.170	△
		△	.170	△
		△	.125	△
REMARKS	CONTACT FINISH	DIM A	PART NUMBER	

THIS DRAWING IS A CONTROLLED DOCUMENT.

DIMENSIONS: INCHES	TOLERANCES UNLESS OTHERWISE SPECIFIED:	DIN S. WELDON 2-27-85	APVD R. BRANDT 2-27-85	NAME	PLUG ASSEMBLY, SIZE 1, 9 POS., VERTICAL, .026 DIA. DUPLEX PLATED TM
0 PLC ± -	1 PLC ± -	2 PLC ± -	3 PLC ± .005	4 PLC ± -	ANGLES ± °
MATERIAL	FINISH	WEIGHT	SIZE	CAGE CODE	DRAWING NO
CONTACTS: SEE TABLE			A1	00779	748003
CUSTOMER DRAWING		SCALE	NTS	SHEET	1 OF 1

STE TE Connectivity