

### FEATURES

- On-chip and remote temperature sensing
- Offset registers for system calibration
- 0.125°C resolution/1°C accuracy on remote channel
- 1°C resolution/3°C accuracy on local channel
- Fast (up to 64 measurements per second)
- 2-wire SMBus serial interface
- Supports SMBus alert
- Programmable under/overtemperature limits
- Programmable fault queue
- Overtemperature fail-safe  $\overline{\text{THERM}}$  output
- Programmable  $\overline{\text{THERM}}$  limits
- Programmable  $\overline{\text{THERM}}$  hysteresis
- 170  $\mu\text{A}$  operating current
- 5.5  $\mu\text{A}$  standby current
- 3 V to 5.5 V supply
- Small 8-lead SOIC and MSOP packages

### APPLICATIONS

- Desktop and notebook computers
- Smart batteries
- Industrial controllers
- Telecommunications equipment
- Instrumentation
- Embedded systems

### GENERAL DESCRIPTION

The ADM1032<sup>1</sup> is a dual-channel digital thermometer and under/overtemperature alarm intended for use in PCs and thermal management systems. The device can measure the temperature of a remote thermal diode, which can be located on the processor die or can be a discrete device (2N3904/06), accurate to 1°C. A novel measurement technique cancels out the absolute value of the transistor's base emitter voltage so that no calibration is required. The ADM1032 also measures its ambient temperature.

The ADM1032 communicates over a 2-wire serial interface compatible with system management bus (SMBus) standards. Under/overtemperature limits can be programmed into the device over the SMBus, and an ALERT output signals when the on-chip or remote temperature measurement is out of range. This output can be used as an interrupt or as a SMBus alert. The  $\overline{\text{THERM}}$  output is a comparator output that allows CPU clock throttling or on/off control of a cooling fan. An ADM1032-1 and ADM1032-2 are available. The difference between the ADM1032 and the ADM1032-1 is the default value of the external THERM limit. The ADM1032-2 has a different SMBus address. The SMBus address of the ADM1032-2 is 0x4D.

<sup>1</sup> Patents 5,982,221; 6,097,239; 6,133,753; 6,169,442; 5,867,012.

### FUNCTIONAL BLOCK DIAGRAM

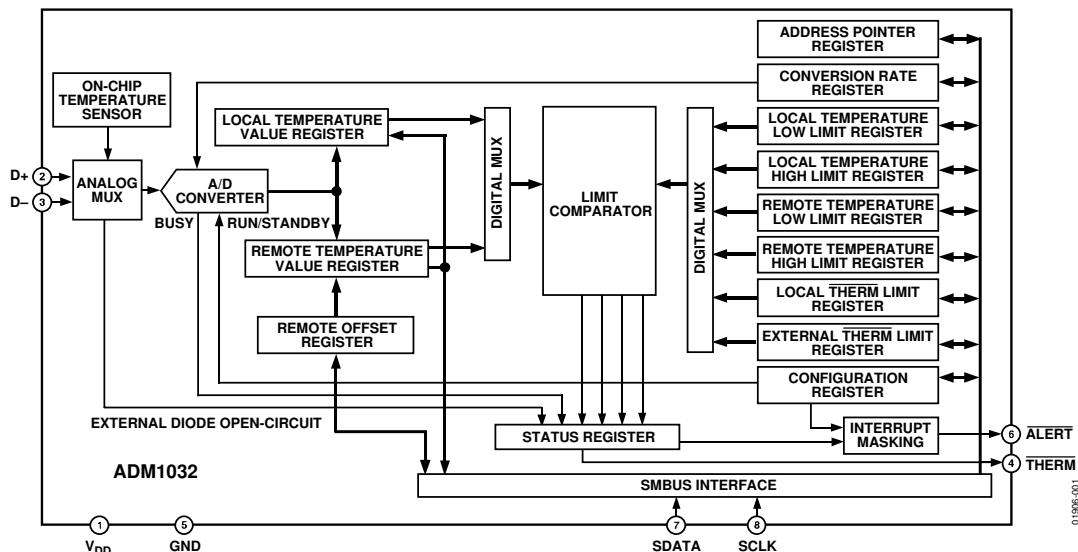

Figure 1.

### Rev. E

Information furnished by Analog Devices is believed to be accurate and reliable. However, no responsibility is assumed by Analog Devices for its use, nor for any infringements of patents or other rights of third parties that may result from its use. Specifications subject to change without notice. No license is granted by implication or otherwise under any patent or patent rights of Analog Devices. Trademarks and registered trademarks are the property of their respective owners.

## TABLE OF CONTENTS

Features .....	1	Serial Bus Interface.....	11
Applications.....	1	Addressing the Device .....	12
General Description .....	1	$\overline{\text{ALERT}}$ Output.....	14
Functional Block Diagram .....	1	Low Power Standby Mode.....	14
Revision History .....	2	The ADM1032 Interrupt System .....	14
Specifications.....	3	Sensor Fault Detection .....	15
Absolute Maximum Ratings.....	4	Applications Information—Factors Affecting Accuracy .....	16
Thermal Characterisitics .....	4	Remote Sensing Diode .....	16
ESD Caution.....	4	Thermal Inertia and Self-Heating.....	16
Pin Configuration and Function Descriptions.....	5	Layout Considerations.....	17
Typical Performance Characteristics .....	6	Application Circuit.....	17
Functional Description .....	8	Outline Dimensions .....	18
Measurement Method.....	8	Ordering Guide .....	19
Temperature Data Format.....	9		
ADM1032 Registers .....	9		

## REVISION HISTORY

### 11/05—Rev. D to Rev. E

Updated Format.....	Universal
Changes to General Description .....	1
Changes to Thermal Characteristics.....	4
Changes to Table 3.....	5
Changes to Measurement Method Section .....	8
Changes to Limit Registers Section.....	10
Changes to Serial Bus Interface Section .....	11
Changes to Ordering Guide .....	19

### 10/04—Rev. C to Rev. D

Changes to Product Description .....	1
Changes to Absolute Maximum Ratings .....	3
Changes to Ordering Guide .....	3
Changes to Addressing the Device Section.....	8
Updated Outline Dimensions .....	14

### 3/03—Rev. B to Rev. C

Edits to Specifications .....	2
-------------------------------	---

### 10/02—Rev. A to Rev. B

Edits to the General Description .....	1
Edits to the Ordering Guide.....	3
Edits to Table VIII .....	8
Outline Dimensions Updated.....	12

## SPECIFICATIONS

Table 1.

Parameter	Min	Typ	Max	Unit	Test Conditions/Comments
<b>POWER SUPPLY</b>					
Supply Voltage, $V_{DD}$	3.0	3.30	5.5	V	
Average Operating Supply Current, $I_{CC}$		170	215	$\mu$ A	0.0625 conversions/sec rate <sup>1</sup>
		5.5	10	$\mu$ A	Standby mode
Undervoltage Lockout Threshold	2.35	2.55	2.8	V	$V_{DD}$ input, disables ADC, rising edge
Power-On Reset Threshold	1		2.4	V	
<b>TEMPERATURE-TO-DIGITAL CONVERTER</b>					
Local Sensor Accuracy		$\pm 1$	$\pm 3$	$^{\circ}$ C	$0 \leq T_A \leq 100^{\circ}$ C, $V_{CC} = 3$ V to 3.6 V
Resolution		1		$^{\circ}$ C	
Remote Diode Sensor Accuracy			$\pm 1$	$^{\circ}$ C	$60^{\circ}$ C $\leq T_D \leq 100^{\circ}$ C, $V_{CC} = 3$ V to 3.6 V
			$\pm 3$	$^{\circ}$ C	$0^{\circ}$ C $\leq T_D \leq 120^{\circ}$ C
Resolution		0.125		$^{\circ}$ C	
Remote Sensor Source Current		230		$\mu$ A	High level <sup>2</sup>
		13		$\mu$ A	Low level <sup>2</sup>
Conversion Time	35.7		142.8	ms	From stop bit to conversion complete
	5.7		22.8	ms	Both channels: one-shot mode with averaging switched on One-shot mode with averaging off (that is, conversion rate = 32 or 64 conversions per second)
<b>OPEN-DRAIN DIGITAL OUTPUTS (THERM, ALERT)</b>					
Output Low Voltage, $V_{OL}$			0.4	V	$I_{OUT} = -6.0$ mA <sup>2</sup>
High Level Output Leakage Current, $I_{OH}$		0.1	1	$\mu$ A	$V_{OUT} = V_{DD}^2$
<b>SERIAL BUS TIMING<sup>2</sup></b>					
Logic Input High Voltage, $V_{IH}$ SCLK, SDATA	2.1			V	$V_{DD} = 3$ V to 5.5 V
Logic Input Low Voltage, $V_{IL}$ Hysteresis SCLK, SDATA		500	0.8	V mV	$V_{DD} = 3$ V to 5.5 V
SDATA Output Low Sink Current ALERT Output Low Sink Current	6 1			mA mA	SDATA forced to 0.6 V ALERT forced to 0.4 V
Logic Input Current, $I_{IH}$ , $I_{IL}$	-1		+1	$\mu$ A	
Input Capacitance, SCLK, SDATA		5		pF	
Clock Frequency			400	kHz	
SMBus Timeout <sup>3</sup>		25	64	ms	
SCLK Clock Low Time, $t_{LOW}$	1.3			$\mu$ s	$t_{LOW}$ between 10% points
SCLK Clock High Time, $t_{HIGH}$	0.6			$\mu$ s	$t_{HIGH}$ between 90% points
Start Condition Setup Time, $t_{SU:STA}$	600			ns	
Start Condition Hold Time, $t_{HD:STA}$	600			ns	Time from 10% of SDATA to 90% of SCLK
Stop Condition Setup Time, $t_{SU:STO}$	600			ns	Time from 90% of SCLK to 10% of SDATA
Data Valid to SCLK Rising Edge Time, $t_{SU:DAT}$	100			ns	Time for 10% or 90% of SDATA to 10% of SCLK
Data Hold Time, $t_{HD:DAT}$	300			ns	
Bus Free Time, $t_{BUF}$	1.3			$\mu$ s	Between start/stop condition
SCLK, SDATA Rise Time, $t_R$			300	ns	
SCLK, SDATA Fall Time, $t_F$			300	ns	

<sup>1</sup> See Table 9 for information on other conversion rates.<sup>2</sup> Guaranteed by design, not production tested.<sup>3</sup> The SMBus timeout is a programmable feature. By default, it is not enabled. Details on how to enable it are available in the Serial Bus Interface section.

## ABSOLUTE MAXIMUM RATINGS

Table 2.

Parameter	Rating
Positive Supply Voltage ( $V_{DD}$ ) to GND	-0.3 V, +5.5 V
D+	-0.3 V to $V_{DD} + 0.3$ V
D- to GND	-0.3 V to +0.6 V
SCLK, SDATA, $\overline{\text{ALERT}}$	-0.3 V to +5.5 V
$\overline{\text{THERM}}$	-0.3 V to $V_{DD} + 0.3$ V
Input Current, SDATA, $\overline{\text{THERM}}$	-1 mA, +50 mA
Input Current, D-	$\pm 1$ mA
ESD Rating, All Pins (Human Body Model)	>1000 V
Maximum Junction Temperature ( $T_J$ Max)	150°C
Storage Temperature Range	-65°C to +150°C
IR Reflow Peak Temperature	220°C
IR Reflow Peak Temperature for Pb-Free	260°C
Lead Temperature (Soldering 10 sec)	300°C

Stresses above those listed under Absolute Maximum Ratings may cause permanent damage to the device. This is a stress rating only; functional operation of the device at these or any other conditions above those indicated in the operational section of this specification is not implied. Exposure to absolute maximum rating conditions for extended periods may affect device reliability.

### THERMAL CHARACTERISTICS

8-Lead SOIC Package:

$$\theta_{JA} = 121^\circ\text{C}$$

8-Lead MSOP Package:

$$\theta_{JA} = 142^\circ\text{C}$$

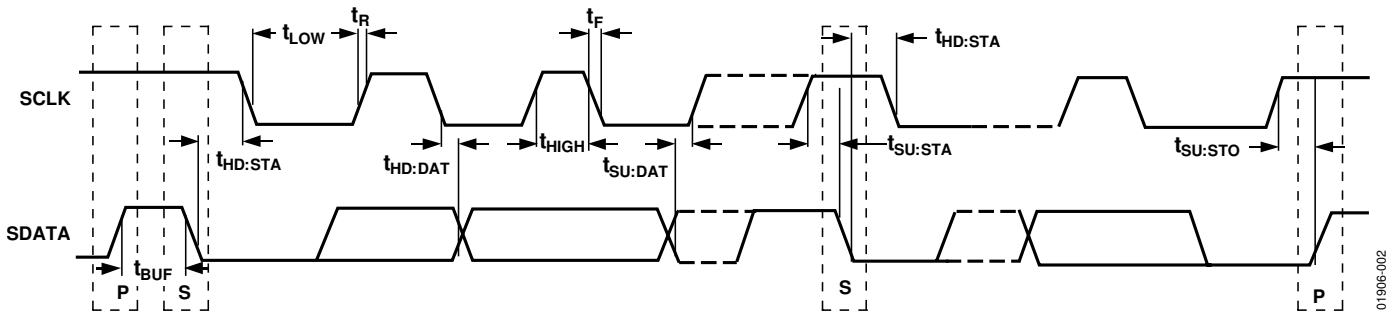

Figure 2. Diagram for Serial Bus Timing

### ESD CAUTION

ESD (electrostatic discharge) sensitive device. Electrostatic charges as high as 4000 V readily accumulate on the human body and test equipment and can discharge without detection. Although this product features proprietary ESD protection circuitry, permanent damage may occur on devices subjected to high energy electrostatic discharges. Therefore, proper ESD precautions are recommended to avoid performance degradation or loss of functionality.



## PIN CONFIGURATION AND FUNCTION DESCRIPTIONS

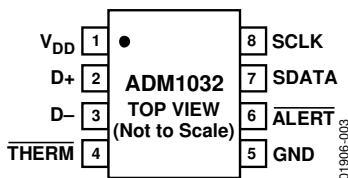

Figure 3. Pin Configuration

Table 3. Pin Function Descriptions

Pin No.	Mnemonic	Description
1	VDD	Positive Supply, 3 V to 5.5 V.
2	D+	Positive Connection to Remote Temperature Sensor.
3	D-	Negative Connection to Remote Temperature Sensor.
4	THERM	THERM is an open-drain output that can be used to turn a fan on/off or throttle a CPU clock in the event of an overtemperature condition. Requires pull-up to V <sub>DD</sub> , the same supply as the ADM1032
5	GND	Supply Ground Connection.
6	ALERT	Open-Drain Logic Output Used as Interrupt or SMBus Alert.
7	SDATA	Logic Input/Output, SMBus Serial Data. Open-drain output. Requires pull-up resistor.
8	SCLK	Logic Input, SMBus Serial Clock. Requires pull-up resistor.

TYPICAL PERFORMANCE CHARACTERISTICS

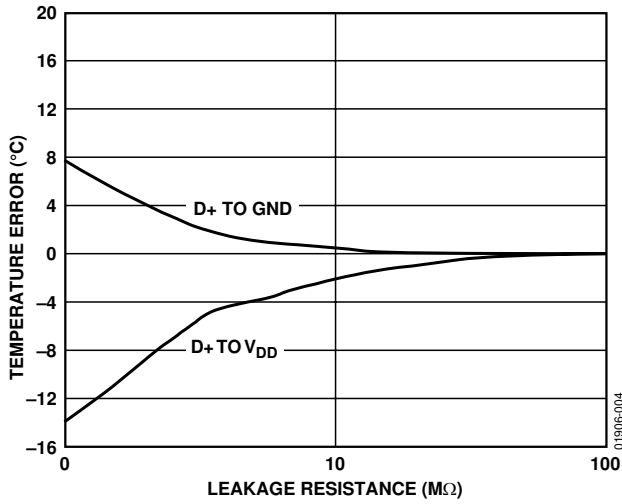

Figure 4. Temperature Error vs. Leakage Resistance

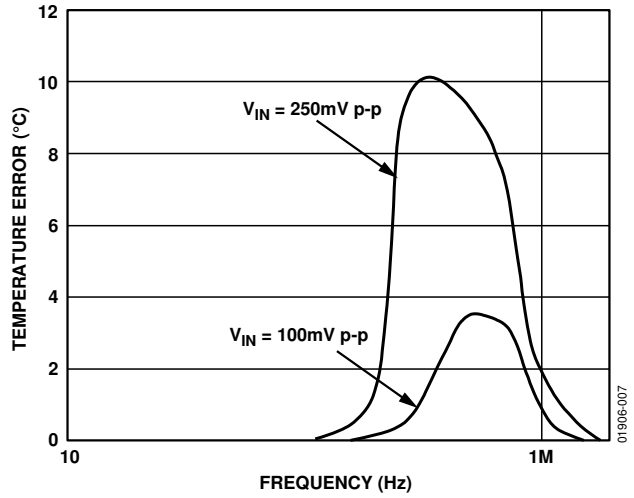

Figure 7. Temperature Error vs. Power Supply Noise Frequency

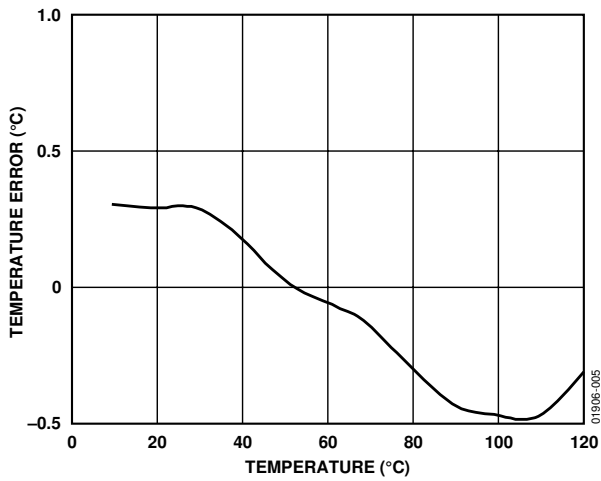

Figure 5. Temperature Error vs. Actual Temperature Using 2N3906

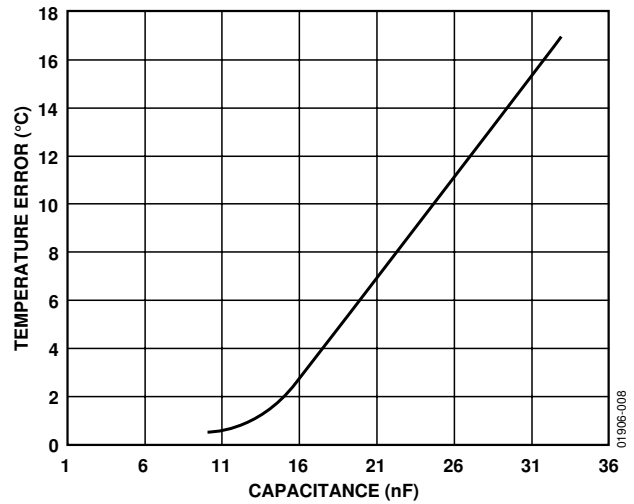

Figure 8. Temperature Error vs. Capacitance Between D+ and D-

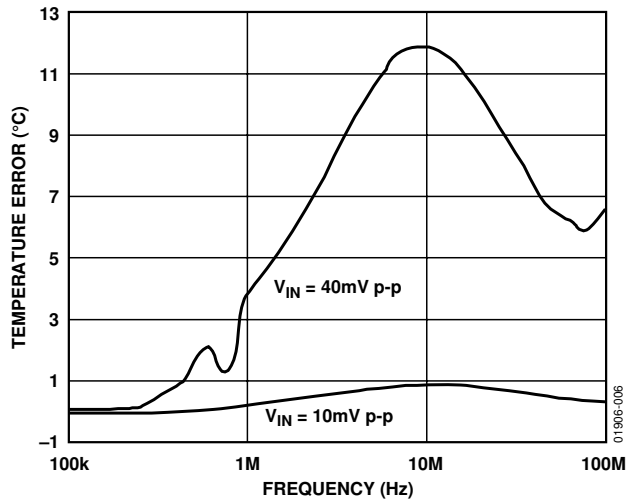

Figure 6. Temperature Error vs. Differential Mode Noise Frequency

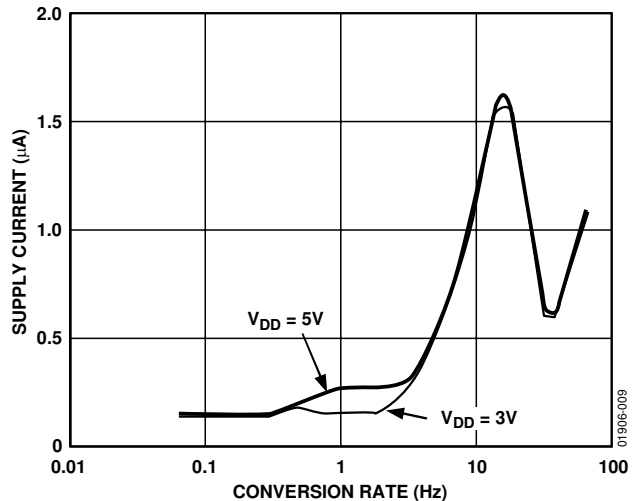

Figure 9. Operating Supply Current vs. Conversion Rate

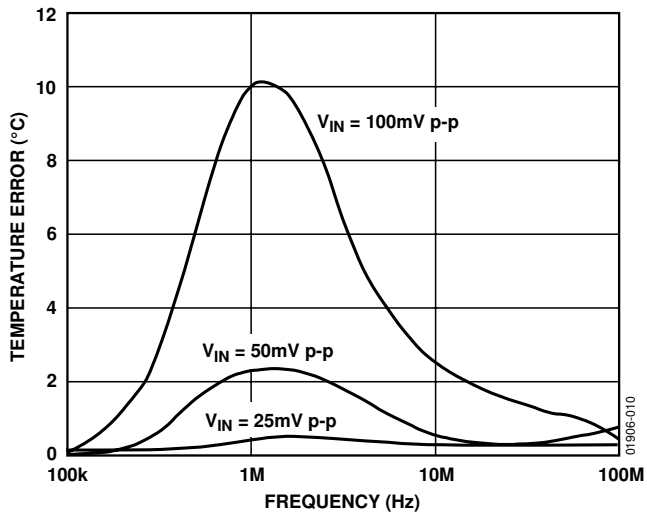

Figure 10. Temperature Error vs. Common-Mode Noise Frequency

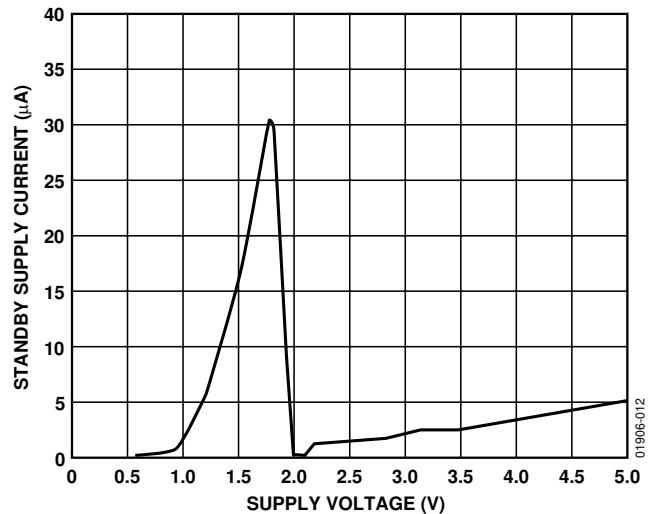

Figure 12. Standby Supply Current vs. Supply Voltage

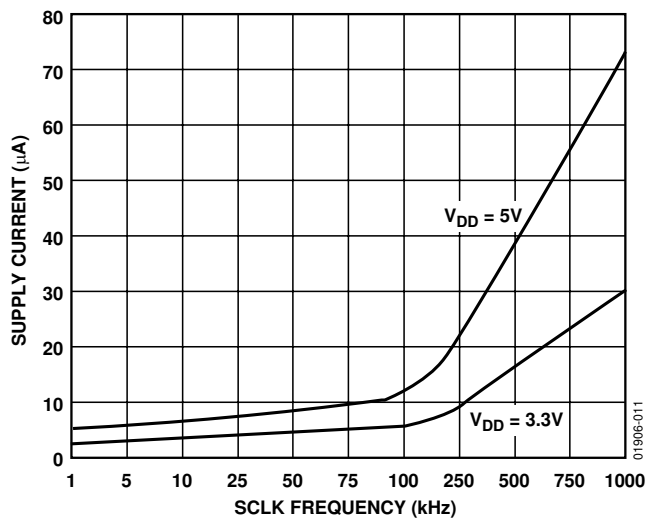

Figure 11. Standby Supply Current vs. Clock Frequency

## FUNCTIONAL DESCRIPTION

The ADM1032 is a local and remote temperature sensor and overtemperature alarm. When the ADM1032 is operating normally, the on-board A/D converter operates in a free running mode. The analog input multiplexer alternately selects either the on-chip temperature sensor to measure its local temperature or the remote temperature sensor. These signals are digitized by the ADC, and the results are stored in the local and remote temperature value registers.

The measurement results are compared with local and remote, high, low, and  $\overline{\text{THERM}}$  temperature limits stored in nine on-chip registers. Out-of-limit comparisons generate flags that are stored in the status register, and one or more out-of-limit results cause the  $\overline{\text{ALERT}}$  output to pull low. Exceeding  $\overline{\text{THERM}}$  temperature limits causes the  $\overline{\text{THERM}}$  output to assert low.

The limit registers can be programmed, and the device controlled and configured, via the serial SMBus. The contents of any register can also be read back via the SMBus.

Control and configuration functions consist of:

- Switching the device between normal operation and standby mode.
- Masking or enabling the  $\overline{\text{ALERT}}$  output.
- Selecting the conversion rate.

## MEASUREMENT METHOD

A simple method of measuring temperature is to exploit the negative temperature coefficient of a diode, or the base-emitter voltage of a transistor, operated at constant current. Unfortunately, this technique requires calibration to null out the effect of the absolute value of  $V_{BE}$ , which varies from device to device.

The technique used in the ADM1032 is to measure the change in  $V_{BE}$  when the device is operated at two different currents.

This is given by

$$\Delta V_{BE} = (n_f) \frac{KT}{q} \times \ln(N)$$

where:

$K$  is Boltzmann's constant ( $1.38 \times 10^{-23}$ ).

$q$  is the charge on the electron ( $1.6 \times 10^{-19}$  Coulombs).

$T$  is the absolute temperature in Kelvins.

$N$  is the ratio of the two currents.

$n_f$  is the ideality factor of the thermal diode.

The ADM1032 is trimmed for an ideality factor of 1.008.

Figure 13 shows the input signal conditioning used to measure the output of an external temperature sensor. Figure 13 shows the external sensor as a substrate transistor, provided for temperature monitoring on some microprocessors, but it could equally well be a discrete transistor. If a discrete transistor is used, the collector is not grounded and should be linked to the base. To prevent ground noise interfering with the measurement, the more negative terminal of the sensor is not referenced to ground but is biased above ground by an internal diode at the  $D-$  input. If the sensor is operating in a noisy environment,  $C1$  can optionally be added as a noise filter. Its value should be no more than 1000 pF. See the Layout Considerations section for more information on  $C1$ .

To measure  $\Delta V_{BE}$ , the sensor is switched between the operating currents of  $I$  and  $N \times I$ . The resulting waveform is passed through a 65 kHz low-pass filter to remove noise, and then to a chopper-stabilized amplifier that performs the functions of amplification and rectification of the waveform to produce a dc voltage proportional to  $\Delta V_{BE}$ . This voltage is measured by the ADC to give a temperature output in twos complement format. To further reduce the effects of noise, digital filtering is performed by averaging the results of 16 measurement cycles.

Signal conditioning and measurement of the internal temperature sensor is performed in a similar manner.

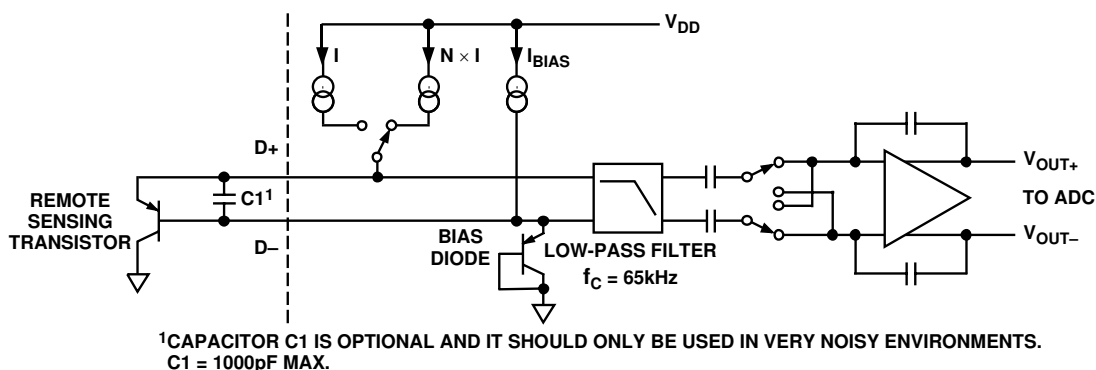

Figure 13. Input Signal Conditioning



## TEMPERATURE DATA FORMAT

One LSB of the ADC corresponds to 0.125°C, so the ADC can measure from 0°C to 127.875°C. The temperature data format is shown in Table 4 and Table 5.

The results of the local and remote temperature measurements are stored in the local and remote temperature value registers and are compared with limits programmed into the local and remote high and low limit registers.

**Table 4. Temperature Data Format (Local Temperature and Remote Temperature High Byte)**

Temperature	Digital Output
0°C	0 000 0000
1°C	0 000 0001
10°C	0 000 1010
25°C	0 001 1001
50°C	0 011 0010
75°C	0 100 1011
100°C	0 110 0100
125°C	0 111 1101
127°C	0 111 1111

**Table 5. Extended Temperature Resolution (Remote Temperature Low Byte)**

Extended Resolution	Remote Temperature Low Byte
0.000°C	0 000 0000
0.125°C	0 010 0000
0.250°C	0 100 0000
0.375°C	0 110 0000
0.500°C	1 000 0000
0.625°C	1 010 0000
0.750°C	1 100 0000
0.875°C	1 110 0000

## ADM1032 REGISTERS

The ADM1032 contains registers that are used to store the results of remote and local temperature measurements and high and low temperature limits and to configure and control the device. A description of these registers follows, and further details are given in Table 6 to Table 10.

### Address Pointer Register

The address pointer register itself does not have, or require, an address because it is the register the first data byte of every write operation is written to automatically. This data byte is an address pointer that sets up one of the other registers for the second byte of the write operation or for a subsequent read operation.

The power-on default value of the address pointer register is 00h. Therefore, if a read operation is performed immediately after power-on without first writing to the address pointer, the value of the local temperature is returned because its register address is 00h.

### Value Registers

The ADM1032 has three registers to store the results of local and remote temperature measurements. These registers are written to by the ADC only and can be read over the SMBus.

### Offset Register

Series resistance on the D+ and D– lines in processor packages and clock noise can introduce offset errors into the remote temperature measurement. To achieve the specified accuracy on this channel, these offsets must be removed.

The offset value is stored as an 11-bit, two's complement value in Register 11h (high byte) and Register 12h (low byte, left justified). The value of the offset is negative if the MSB of Register 11h is 1 and positive if the MSB of Register 12h is 0. The value is added to the measured value of the remote temperature.

The offset register powers up with a default value of 0°C and has no effect if nothing is written to them.

**Table 6. Sample Offset Register Codes**

Offset Value	11h	12h
–4°C	1 111 1100	0 000 0000
–1°C	1 111 1111	0 000 0000
–0.125°C	1 111 1111	1 110 0000
0°C	0 000 0000	0 000 0000
+0.125°C	0 000 0000	0 010 0000
+1°C	0 000 0001	0 000 0000
+4°C	0 000 0100	0 000 0000

### Status Register

Bit 7 of the status register indicates that the ADC is busy converting when it is high. Bit 6 to Bit 3, Bit 1, and Bit 0 are flags that indicate the results of the limit comparisons. Bit 2 is set when the remote sensor is open circuit.

If the local and/or remote temperature measurement is above the corresponding high temperature limit, or below or equal to the corresponding low temperature limit, one or more of these flags is set. These five flags (Bit 6 to Bit 2) are NOR'ed together, so that if any of them are high, the  $\overline{\text{ALERT}}$  interrupt latch is set and the  $\overline{\text{ALERT}}$  output goes low. Reading the status register clears the five flag bits, provided that the error conditions that caused the flags to be set have gone away. While a limit comparator is tripped due to a value register containing an out-of-limit measurement, or the sensor is open circuit, the corresponding flag bit cannot be reset. A flag bit can only be reset if the corresponding value register contains an in-limit measurement or the sensor is good.

The  $\overline{\text{ALERT}}$  interrupt latch is not reset by reading the status register but is reset when the  $\overline{\text{ALERT}}$  output is serviced by the master reading the device address, provided the error condition has gone away and the status register flag bits are reset.

# ADM1032

When Flag 1 and Flag 0 are set, the  $\overline{\text{THERM}}$  output goes low to indicate that the temperature measurements are outside the programmed limits.  $\overline{\text{THERM}}$  output does not need to be reset, unlike the  $\overline{\text{ALERT}}$  output. Once the measurements are within the limits, the corresponding status register bits are reset and the  $\overline{\text{THERM}}$  output goes high.

**Table 7. Status Register Bit Assignments**

Bit	Name	Function
7	BUSY	1 When ADC Converting
6	LHIGH <sup>1</sup>	1 When Local High Temp Limit Tripped
5	LLOW <sup>1</sup>	1 When Local Low Temp Limit Tripped
4	RHIGH <sup>1</sup>	1 When Remote High Temp Limit Tripped
3	RLOW <sup>1</sup>	1 When Remote Low Temp Limit Tripped
2	OPEN <sup>1</sup>	1 When Remote Sensor Open-Circuit
1	RTHRM	1 When Remote $\overline{\text{THERM}}$ Limit Tripped
0	LTHRM1	1 When Local $\overline{\text{THERM}}$ Limit Tripped

<sup>1</sup>These flags stay high until the status register is read, or they are reset by POR.

## Configuration Register

Two bits of the configuration register are used. If Bit 6 is 0, which is the power-on default, the device is in operating mode with the ADC converting. If Bit 6 is set to 1, the device is in standby mode and the ADC does not convert. The SMBus does, however, remain active in standby mode so values can be read from or written to the SMBus. The  $\overline{\text{ALERT}}$  and  $\overline{\text{THERM}}$  O/Ps are also active in standby mode.

Bit 7 of the configuration register is used to mask the alert output. If Bit 7 is 0, which is the power-on default, the output is enabled. If Bit 7 is set to 1, the output is disabled.

**Table 8. Configuration Register Bit Assignments**

Bit	Name	Function	Power-On Default
7	MASK1	0 = $\overline{\text{ALERT}}$ Enabled 1 = $\overline{\text{ALERT}}$ Masked	0
6	RUN/STOP	0 = Run 1 = Standby	0
5 to 0		Reserved	0

## Conversion Rate Register

The lowest four bits of this register are used to program the conversion rate by dividing the internal oscillator clock by 1, 2, 4, 8, 16, 32, 64, 128, 256, 512, or 1024 to give conversion times from 15.5 ms (Code 0Ah) to 16 seconds (Code 00h). This register can be written to and read back over the SMBus. The higher four bits of this register are unused and must be set to 0. Use of slower conversion times greatly reduces the device power consumption, as shown in Table 9.

**Table 9. Conversion Rate Register Codes**

Data	Conversion/Sec	Average Supply Current mA Typ at VDD = 5.5 V
00h	0.0625	0.17
01h	0.125	0.20
02h	0.25	0.21
03h	0.5	0.24
04h	1	0.29
05h	2	0.40
06h	4	0.61
07h	8	1.1
08h	16	1.9
09h	32	0.73
0Ah	64	1.23
0B to FFh	Reserved	

## Limit Registers

The ADM1032 has nine limit registers to store local and remote, high, low, and  $\overline{\text{THERM}}$  temperature limits. These registers can be written to and read back over the SMBus.

The high limit registers perform a > comparison, while the low limit registers perform a < or = to comparison. For example, if the high limit register is programmed with 80°C, measuring 81°C results in an alarm condition. If the low limit register is programmed with 0°C, measuring 0°C or lower results in an alarm condition. Exceeding either the local or remote  $\overline{\text{THERM}}$  limit asserts  $\overline{\text{THERM}}$  low. A default hysteresis value of 10°C is provided, which applies to both channels. This hysteresis can be reprogrammed to any value after power up (Reg 0x21h).

## One-Shot Register

The one-shot register is used to initiate a single conversion and comparison cycle when the ADM1032 is in standby mode, after which the device returns to standby. This is not a data register as such, and it is the write operation that causes the one-shot conversion. The data written to this address is irrelevant and is not stored. The conversion time on a single shot is 96 ms when the conversion rate is 16 conversions per second or less. At 32 conversions per second, the conversion time is 15.3 ms. This is because averaging is disabled at the faster conversion rates (32 and 64 conversions per second).

## Consecutive $\overline{\text{ALERT}}$ Register

This value written to this register determines how many out-of-limit measurements must occur before an  $\overline{\text{ALERT}}$  is generated. The default value is that one out-of-limit measurement generates an  $\overline{\text{ALERT}}$ . The maximum value that can be chosen is four. The purpose of this register is to allow the user to perform some filtering of the output. This is particularly useful at the faster two conversion rates where no averaging takes place.

**Table 10. Consecutive  $\overline{\text{ALERT}}$  Register Codes**

Register Value	Number of Out-of-Limit Measurements Required
yxxx 000x	1
yxxx 001x	2
yxxx 011x	3
yxxx 111x	4

Note that x = don't care bits, and y = SMBus timeout bit. Default = 0. See SMBus section for more information.

**SERIAL BUS INTERFACE**

Control of the ADM1032 is carried out via the serial bus. The ADM1032 is connected to this bus as a slave device, under the control of a master device.

There is a programmable SMBus timeout. When this is enabled, the SMBus times out after typically 25 ms of no activity. However, this feature is not enabled by default. To enable it, set Bit 7 of the consecutive alert register (Address = 22h).

**Table 11. List of ADM1032 Registers**

Read Address (Hex)	Write Address (Hex)	Name	Power-On Default
Not Applicable	Not Applicable	Address Pointer	Undefined
00	Not Applicable	Local Temperature Value	0000 0000 (00h)
01	Not Applicable	External Temperature Value High Byte	0000 0000 (00h)
02	Not Applicable	Status	Undefined
03	09	Configuration	0000 0000 (00h)
04	0A	Conversion Rate	0000 1000 (08h)
05	0B	Local Temperature High Limit	0101 0101 (55h) (85°C)
06	0C	Local Temperature Low Limit	0000 0000 (00h) (0°C)
07	0D	External Temperature High Limit High Byte	0101 0101 (55h) (85°C)
08	0E	External Temperature Low Limit High Byte	0000 0000 (00h) (0°C)
Not Applicable	0F	One-Shot	
10	Not Applicable	External Temperature Value Low Byte	0000 0000
11	11	External Temperature Offset High Byte	0000 0000
12	12	External Temperature Offset Low Byte	0000 0000
13	13	External Temperature High Limit Low Byte	0000 0000
14	14	External Temperature Low Limit Low Byte	0000 0000
19	19	External $\overline{\text{THERM}}$ Limit	0101 0101 (55h) (85°C) (ADM1032) 0110 1100 (6Ch) (108°C) (ADM1032-1)
20	20	Local $\overline{\text{THERM}}$ Limit	0101 0101 (55h) (85°C)
21	21	$\overline{\text{THERM}}$ Hysteresis	0000 1010 (0Ah) (10°C)
22	22	Consecutive $\overline{\text{ALERT}}$	0000 0001 (01h)
FE	Not Applicable	Manufacturer ID	0100 0001 (41h)
FF	Not Applicable	Die Revision Code	Undefined

Writing to Address 0F causes the ADM1032 to perform a single measurement. It is not a data register as such and it does not matter what data is written to it.

## ADDRESSING THE DEVICE

In general, every SMBus device has a 7-bit device address (except for some devices that have extended, 10-bit addresses).

When the master device sends a device address over the bus, the slave device with that address responds. The ADM1032 and the ADM1032-1 are available with one SMBUS address, which is Hex 4C (1001 100). The ADM1032-2 is also available with one SMBUS address; however, that address is Hex 4D (1001 101).

The serial bus protocol operates as follows:

1. The master initiates data transfer by establishing a START condition, defined as a high-to-low transition on the serial data line SDATA, while the serial clock line SCLK remains high. This indicates that an address/data stream follows. All slave peripherals connected to the serial bus respond to the START condition and shift in the next eight bits, consisting of a 7-bit address (MSB first) plus an R/W bit, which determines the direction of the data transfer, that is, whether data is written to or read from the slave device.

The peripheral whose address corresponds to the transmitted address responds by pulling the data line low during the low period before the ninth clock pulse, known as the acknowledge bit. All other devices on the bus now remain idle while the selected device waits for data to be read from or written to it. If the R/W bit is a 0, the master writes to the slave device. If the R/W bit is a 1, the master reads from the slave device.

2. Data is sent over the serial bus in sequences of nine clock pulses, eight bits of data followed by an acknowledge bit from the slave device. Transitions on the data line must occur during the low period of the clock signal and remain stable during the high period, since a low-to-high transition when the clock is high can be interpreted as a STOP signal. The number of data bytes that can be transmitted over the serial bus in a single read or write operation is limited only by what the master and slave devices can handle.
3. When all data bytes are read or written, stop conditions are established. In write mode, the master pulls the data line high during the 10th clock pulse to assert a STOP condition. In read mode, the master device overrides the acknowledge bit by pulling the data line high during the low period before the ninth clock pulse. This is known as no acknowledge. The master then takes the data line low during the low period before the 10th clock pulse, and high during the 10th clock pulse to assert a STOP condition.

Any number of bytes of data can be transferred over the serial bus in one operation, but it is not possible to mix read and write in one operation because the type of operation is determined at the beginning and cannot subsequently be changed without starting a new operation.

In the case of the ADM1032, write operations contain either one or two bytes, while read operations contain one byte and perform the following functions.

To write data to one of the device data registers or read data from it, the address pointer register must first be set so that the correct data register is addressed. The first byte of a write operation always contains a valid address that is stored in the address pointer register. If data is written to the device, the write operation contains a second data byte that is written to the register selected by the address pointer register.

This is illustrated in Figure 14. The device address is sent over the bus followed by R/W set to 0. This is followed by two data bytes. The first data byte is the address of the internal data register to be written to, which is stored in the address pointer register. The second data byte is the data to be written to the internal data register.

When reading data from a register, there are two possibilities:

- If the address pointer register value is unknown or not the desired value, it is first necessary to set it to the correct value before data can be read from the desired data register. This is done by performing a write to the ADM1032 as before, but only the data byte containing the register read address is sent because data is not to be written to the register. This is shown in Figure 15.

A read operation is then performed consisting of the serial bus address, R/W bit set to 1, followed by the data byte read from the data register. This is shown in Figure 16.

- If the address pointer register is known to be at the desired address already, data can be read from the corresponding data register without first writing to the address pointer register and Figure 15 can be omitted.

### Notes

Although it is possible to read a data byte from a data register without first writing to the address pointer register, if the address pointer register is already at the correct value, it is not possible to write data to a register without writing to the address pointer register. The first data byte of a write is always written to the address pointer register.

Don't forget that some of the ADM1032 registers have different addresses for read and write operations. The write address of a register must be written to the address pointer if data is to be written to that register, but it is not possible to read data from that address. The read address of a register must be written to the address pointer before data can be read from that register.

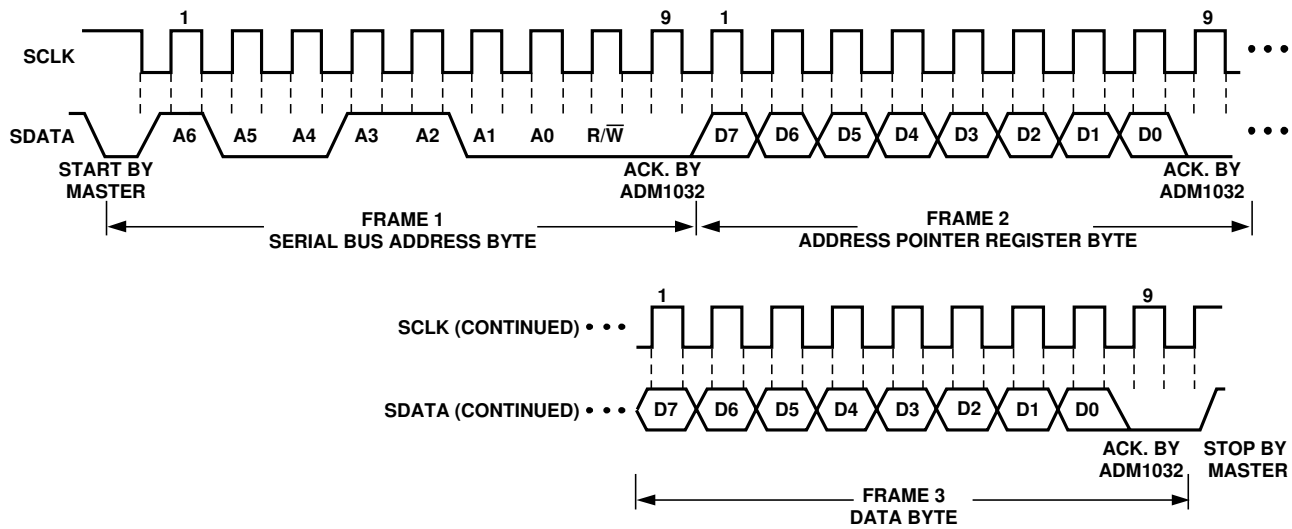

Figure 14. Writing a Register Address to the Address Pointer Register, then Writing Data to the Selected Register

01906-014

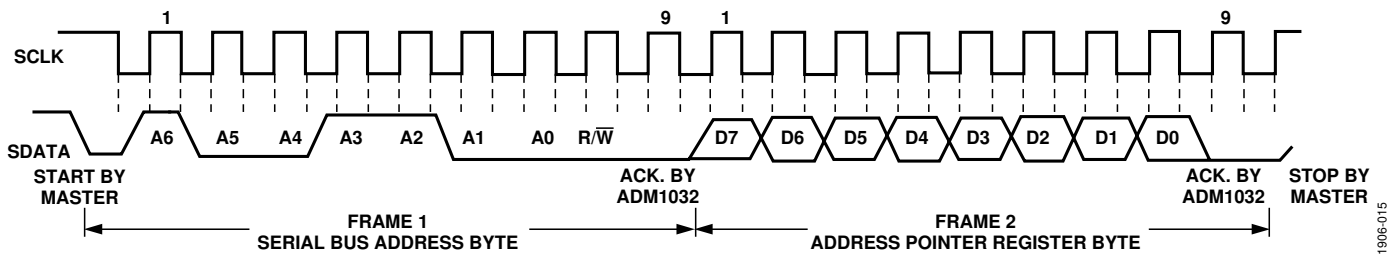

Figure 15. Writing to the Address Pointer Register Only

01906-015

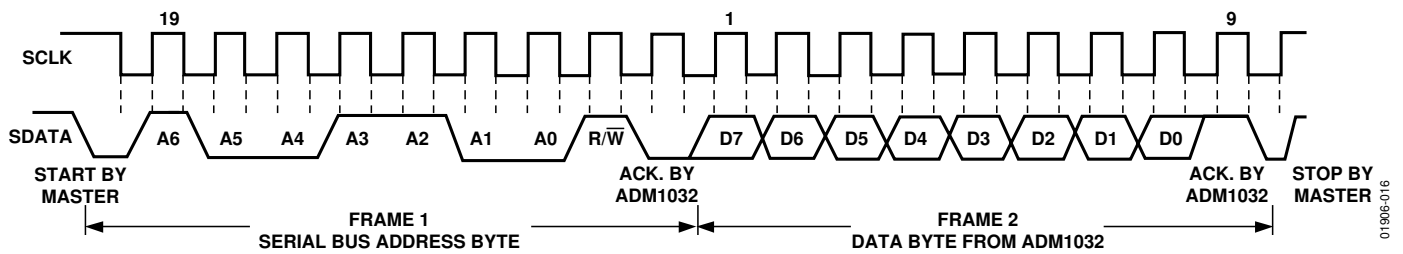

Figure 16. Reading Data from a Previously Selected Register

01906-016

## ALERT OUTPUT

The  $\overline{\text{ALERT}}$  output goes low whenever an out-of-limit measurement is detected, or if the remote temperature sensor is open-circuit. It is an open drain and requires a pull-up to  $V_{\text{DD}}$ . Several  $\overline{\text{ALERT}}$  outputs can be wire-ORed together so that the common line goes low if one or more of the  $\overline{\text{ALERT}}$  outputs goes low.

The  $\overline{\text{ALERT}}$  output can be used as an interrupt signal to a processor, or it can be used as an  $\overline{\text{SMBALERT}}$ . Slave devices on the SMBus can not normally signal to the master that they want to talk, but the  $\overline{\text{SMBALERT}}$  function allows them to do so.

One or more  $\overline{\text{ALERT}}$  outputs can be connected to a common  $\overline{\text{SMBALERT}}$  line connected to the master. When the  $\overline{\text{SMBALERT}}$  line is pulled low by one of the devices, the following procedure occurs (see Figure 17).

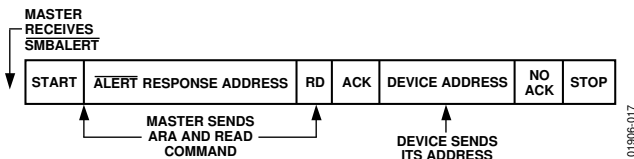

Figure 17. Use of  $\overline{\text{SMBALERT}}$

1.  $\overline{\text{SMBALERT}}$  is pulled low.
2. Master initiates a read operation and sends the alert response address (ARA = 0001 100). This is a general call address that must not be used as a specific device address.
3. The device whose  $\overline{\text{ALERT}}$  output is low responds to the alert response address and the master reads its device address. Since the device address is seven bits, an LSB of 1 is added. The address of the device is now known, and it can be interrogated in the usual way.
4. If more than one device's  $\overline{\text{ALERT}}$  output is low, the one with the lowest device address has priority in accordance with normal SMBus arbitration.
5. Once the ADM1032 has responded to the alert response address, it resets its  $\overline{\text{ALERT}}$  output, provided that the error condition that caused the  $\overline{\text{ALERT}}$  no longer exists. If the  $\overline{\text{SMBALERT}}$  line remains low, the master sends ARA again, and so on until all devices whose  $\overline{\text{ALERT}}$  outputs were low have responded.

## LOW POWER STANDBY MODE

The ADM1032 can be put into a low power standby mode by setting Bit 6 of the configuration register. When Bit 6 is low, the ADM1032 operates normally. When Bit 6 is high, the ADC is inhibited and any conversion in progress is terminated without writing the result to the corresponding value register.

The SMBus is still enabled. Power consumption in the standby mode is reduced to less than 10  $\mu\text{A}$  if there is no SMBus activity, or 100  $\mu\text{A}$  if there are clock and data signals on the bus.

When the device is in standby mode, it is still possible to initiate a one-shot conversion of both channels by writing XXh to the one-shot register (Address 0Fh), after which the device returns to standby. It is also possible to write new values to the limit register while it is in standby. If the values stored in the temperature value registers are now outside the new limits, an  $\overline{\text{ALERT}}$  is generated even though the ADM1032 is still in standby.

## THE ADM1032 INTERRUPT SYSTEM

The ADM1032 has two interrupt outputs,  $\overline{\text{ALERT}}$  and  $\overline{\text{THERM}}$ . These have different functions.  $\overline{\text{ALERT}}$  responds to violations of software-programmed temperature limits and is maskable.  $\overline{\text{THERM}}$  is intended as a fail-safe interrupt output that cannot be masked.

If the temperature goes equal to or below the lower temperature limit, the  $\overline{\text{ALERT}}$  pin is asserted low to indicate an out-of-limit condition. If the temperature is within the programmed low and high temperature limits, no interrupt is generated.

If the temperature exceeds the high temperature limit, the  $\overline{\text{ALERT}}$  pin is asserted low to indicate an overtemperature condition. A local and remote  $\overline{\text{THERM}}$  limit can be programmed into the device to set the temperature limit above which the overtemperature  $\overline{\text{THERM}}$  pin is asserted low. This temperature limit should be equal to or greater than the high temperature limit programmed.

The behavior of the high limit and  $\overline{\text{THERM}}$  limit is as follows:

1. If either temperature measured exceeds the high temperature limit, the  $\overline{\text{ALERT}}$  output is asserted low.
2. If the local or remote temperature continues to increase and either one exceeds the  $\overline{\text{THERM}}$  limit, the  $\overline{\text{THERM}}$  output asserts low. This can be used to throttle the CPU clock or switch on a fan.

A  $\overline{\text{THERM}}$  hysteresis value is provided to prevent a cooling fan cycling on and off. The power-on default value is 10°C, but this can be reprogrammed to any value after power-up. This hysteresis value applies to both the local and remote channels.

Using these two limits in this way, allows the user to gain maximum performance from the system by only slowing it down should it be at a critical temperature.

The  $\overline{\text{THERM}}$  signal is open drain and requires a pull-up to  $V_{DD}$ . The  $\overline{\text{THERM}}$  signal must always be pulled up to the same power supply as the ADM1032, unlike the SMBus signals (SDATA, SCLK, and  $\overline{\text{ALERT}}$ ) that can be pulled to a different power rail, usually that of the SMBus controller.

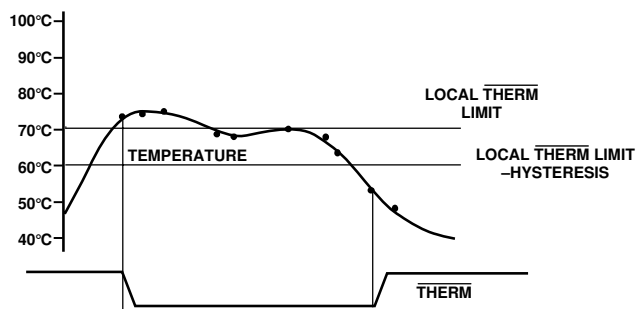

Figure 18. Operation of the  $\overline{\text{THERM}}$  Output

Table 12.  $\overline{\text{THERM}}$  Hysteresis Sample Values

$\overline{\text{THERM}}$ Hysteresis	Binary Representation
0°C	0 000 0000
1°C	0 000 0001
10°C	0 000 1010

## SENSOR FAULT DETECTION

At the D+ input, the ADM1032 has a fault detector that detects if the external sensor diode is open circuit. This is a simple voltage comparator that trips if the voltage at D+ exceeds  $V_{DD} - 1\text{ V}$  (typical). The output of this comparator is checked when a conversion is initiated and sets Bit 2 of the status register if a fault is detected.

If the remote sensor voltage falls below the normal measuring range, for example, due to the diode being short-circuited, the ADC outputs  $-128$  (1000 0000). Since the normal operating temperature range of the device only extends down to  $0^\circ\text{C}$ , this output code should never be seen in normal operation, so it can be interpreted as a fault condition. Since it is outside the power-on default low temperature limit ( $0^\circ\text{C}$ ) and any low limit that would normally be programmed, a short-circuit sensor causes an SMBus alert.

In this respect, the ADM1032 differs from and improves upon competitive devices that output zero if the external sensor goes short-circuit. These devices can misinterpret a genuine  $0^\circ\text{C}$  measurement as a fault condition.

When the D+ and D- lines are shorted together, an  $\overline{\text{ALERT}}$  is always generated. This is because the remote value register reports a temperature value of  $-128^\circ\text{C}$ . Since the ADM1032 performs a less-than or equal-to comparison with the low limit, an  $\overline{\text{ALERT}}$  is generated even when the low limit is set to its minimum of  $-128^\circ\text{C}$ .

## APPLICATIONS INFORMATION—FACTORS AFFECTING ACCURACY

### REMOTE SENSING DIODE

The ADM1032 is designed to work with substrate transistors built into processors' CPUs or with discrete transistors. Substrate transistors are generally PNP types with the collector connected to the substrate. Discrete types can be either a PNP or an NPN transistor connected as a diode (base shorted to collector). If an NPN transistor is used, the collector and base are connected to D+ and the emitter to D-. If a PNP transistor is used, the collector and base are connected to D- and the emitter to D+. Substrate transistors are found in a number of CPUs. To reduce the error due to variations in these substrate and discrete transistors, a number of factors should be taken into consideration:

1. The ideality factor,  $n_f$ , of the transistor. The ideality factor is a measure of the deviation of the thermal diode from the ideal behavior. The ADM1032 is trimmed for an  $n_f$  value of 1.008. The following equation can be used to calculate the error introduced at a temperature  $T^\circ\text{C}$  when using a transistor whose  $n_f$  does not equal 1.008. Consult the processor data sheet for  $n_f$  values.

$$\Delta T = \frac{(n_{\text{natural}} - 1.008)}{1.008} \times (273.15 \text{ Kelvin} + T)$$

This value can be written to the offset register and is automatically added to or subtracted from the temperature measurement.

2. Some CPU manufacturers specify the high and low current levels of the substrate transistors. The high current level of the ADM1032,  $I_{\text{HIGH}}$ , is 230  $\mu\text{A}$  and the low level current,  $I_{\text{LOW}}$ , is 13  $\mu\text{A}$ . If the ADM1032 current levels do not match the levels of the CPU manufacturers, then it can become necessary to remove an offset. The CPU's data sheet advises whether this offset needs to be removed and how to calculate it. This offset can be programmed to the offset register. It is important to note that if accounting for two or more offsets is needed, then the algebraic sum of these offsets must be programmed to the offset register.

If a discrete transistor is being used with the ADM1032, the best accuracy is obtained by choosing devices according to the following criteria:

- Base-emitter voltage greater than 0.25 V at 6 mA, at the highest operating temperature.
- Base-emitter voltage less than 0.95 V at 100 mA, at the lowest operating temperature.
- Base resistance less than 100  $\Omega$ .
- Small variation in  $h_{\text{FE}}$  (say 50 to 150) that indicates tight control of  $V_{\text{BE}}$  characteristics.

Transistors such as 2N3904, 2N3906, or equivalents in SOT-23 packages are suitable devices to use.

### THERMAL INERTIA AND SELF-HEATING

Accuracy depends on the temperature of the remote-sensing diode and/or the internal temperature sensor being at the same temperature as that being measured, and a number of factors can affect this. Ideally, the sensor should be in good thermal contact with the part of the system being measured, for example, the processor. If it is not, the thermal inertia caused by the mass of the sensor causes a lag in the response of the sensor to a temperature change. In the case of the remote sensor, this should not be a problem, since it is either a substrate transistor in the processor or a small package device, such as the SOT-23, placed in close proximity to it.

The on-chip sensor, however, is often remote from the processor and is only monitoring the general ambient temperature around the package. The thermal time constant of the SOIC-8 package in still air is about 140 seconds, and if the ambient air temperature quickly changed by 100°, it would take about 12 minutes (five time constants) for the junction temperature of the ADM1032 to settle within 1° of this. In practice, the ADM1032 package is in electrical and therefore thermal contact with a printed circuit board and can also be in a forced airflow. How accurately the temperature of the board and/or the forced airflow reflect the temperature to be measured also affects the accuracy.

Self-heating due to the power dissipated in the ADM1032 or the remote sensor causes the chip temperature of the device or remote sensor to rise above ambient. However, the current forced through the remote sensor is so small that self-heating is negligible. In the case of the ADM1032, the worst-case condition occurs when the device is converting at 16 conversions per second while sinking the maximum current of 1 mA at the ALERT and THERM output. In this case, the total power dissipation in the device is about 11 mW. The thermal resistance,  $\theta_{\text{JA}}$ , of the SOIC-8 package is about 121°C/W.

In practice, the package has electrical and therefore thermal connection to the printed circuit board, so the temperature rise due to self-heating is negligible.



## LAYOUT CONSIDERATIONS

Digital boards can be electrically noisy environments, and the ADM1032 is measuring very small voltages from the remote sensor, so care must be taken to minimize noise induced at the sensor inputs. The following precautions should be taken.

1. Place the ADM1032 as close as possible to the remote sensing diode. Provided that the worst noise sources, that is, clock generators, data/address buses, and CRTs, are avoided, this distance can be four to eight inches.
2. Route the D+ and D- tracks close together, in parallel, with grounded guard tracks on each side. Provide a ground plane under the tracks if possible.
3. Use wide tracks to minimize inductance and reduce noise pickup. 10 mil track minimum width and spacing is recommended.



Figure 19. Arrangement of Signal Tracks

4. Try to minimize the number of copper/solder joints, which can cause thermocouple effects. Where copper/solder joints are used, make sure that they are in both the D+ and D- path and at the same temperature.

Thermocouple effects should not be a major problem since 1°C corresponds to about 200 μV and thermocouple voltages are about 3 μV/°C of temperature difference. Unless there are two thermocouples with a big temperature differential between them, thermocouple voltages should be much less than 200 μV.

5. Place a 0.1 μF bypass capacitor close to the V<sub>DD</sub> pin. In very noisy environments, place a 1000 pF input filter capacitor across D+ and D- close to the ADM1032.

6. If the distance to the remote sensor is more than eight inches, the use of twisted pair cable is recommended. This works up to about six feet to 12 feet.
7. For really long distances (up to 100 feet), use shielded twisted pair, such as Belden #8451 microphone cable. Connect the twisted pair to D+ and D- and the shield to GND close to the ADM1032. Leave the remote end of the shield unconnected to avoid ground loops.

Because the measurement technique uses switched current sources, excessive cable and/or filter capacitance can affect the measurement. When using long cables, the filter capacitor can be reduced or removed.

Cable resistance can also introduce errors. 1 Ω series resistance introduces about 1°C error.

## APPLICATION CIRCUIT

Figure 20 shows a typical application circuit for the ADM1032, using a discrete sensor transistor connected via a shielded, twisted pair cable. The pull-ups on SCLK, SDATA, and ALERT are required only if they are not already provided elsewhere in the system.

The SCLK and SDATA pins of the ADM1032 can be interfaced directly to the SMBus of an I/O controller, such as the Intel 820 chipset.

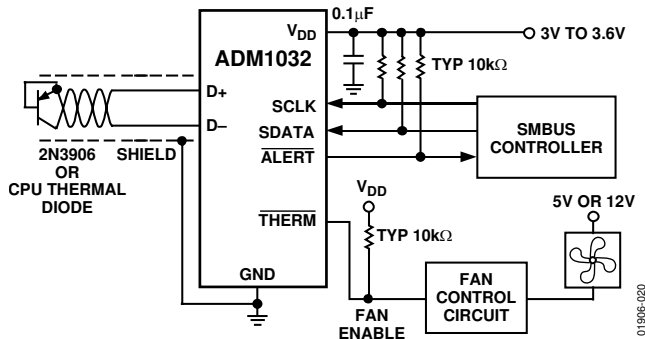
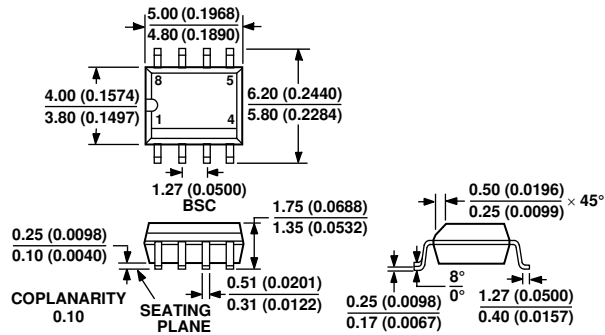

Figure 20. Typical Application Circuit

OUTLINE DIMENSIONS



COMPLIANT TO JEDEC STANDARDS MS-012-AA  
 CONTROLLING DIMENSIONS ARE IN MILLIMETERS; INCH DIMENSIONS  
 (IN PARENTHESES) ARE ROUNDED-OFF MILLIMETER EQUIVALENTS FOR  
 REFERENCE ONLY AND ARE NOT APPROPRIATE FOR USE IN DESIGN.

Figure 21. 8-Lead Standard Small Outline Package [SOIC\_N]  
 Narrow Body (R-8)  
 Dimensions shown in millimeters and (inches)

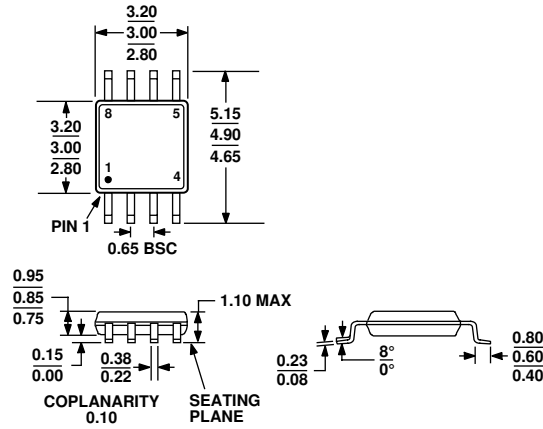

COMPLIANT TO JEDEC STANDARDS MO-187-AA

Figure 22. 8-Lead Mini Small Outline Package [MSOP]  
 (RM-8)  
 Dimensions shown in millimeters

## ORDERING GUIDE

Model	Temperature Range	Package Description	Package Option	Branding	SMBus Addr	External THERM Default
ADM1032AR	0°C to 120°C	8-Lead SOIC_N	R-8		4C	85°C
ADM1032AR-REEL	0°C to 120°C	8-Lead SOIC_N	R-8		4C	85°C
ADM1032AR-REEL7	0°C to 120°C	8-Lead SOIC_N	R-8		4C	85°C
ADM1032ARZ <sup>1</sup>	0°C to 120°C	8-Lead SOIC_N	R-8		4C	85°C
ADM1032ARZ-REEL <sup>1</sup>	0°C to 120°C	8-Lead SOIC_N	R-8		4C	85°C
ADM1032ARZ-REEL7 <sup>1</sup>	0°C to 120°C	8-Lead SOIC_N	R-8		4C	85°C
ADM1032AR-1	0°C to 120°C	8-Lead SOIC_N	R-8		4C	108°C
ADM1032AR-1REEL	0°C to 120°C	8-Lead SOIC_N	R-8		4C	108°C
ADM1032AR-1REEL7	0°C to 120°C	8-Lead SOIC_N	R-8		4C	108°C
ADM1032ARZ-1 <sup>1</sup>	0°C to 120°C	8-Lead SOIC_N	R-8		4C	108°C
ADM1032ARZ-1REEL <sup>1</sup>	0°C to 120°C	8-Lead SOIC_N	R-8		4C	108°C
ADM1032ARZ-1REEL7 <sup>1</sup>	0°C to 120°C	8-Lead SOIC_N	R-8		4C	108°C
ADM1032ARM	0°C to 120°C	8-Lead MSOP	RM-8	T2A	4C	85°C
ADM1032ARM-REEL	0°C to 120°C	8-Lead MSOP	RM-8	T2A	4C	85°C
ADM1032ARM-REEL7	0°C to 120°C	8-Lead MSOP	RM-8	T2A	4C	85°C
ADM1032ARMZ <sup>1</sup>	0°C to 120°C	8-Lead MSOP	RM-8	T1J	4C	85°C
ADM1032ARMZ-REEL <sup>1</sup>	0°C to 120°C	8-Lead MSOP	RM-8	T1J	4C	85°C
ADM1032ARMZ-REEL7 <sup>1</sup>	0°C to 120°C	8-Lead MSOP	RM-8	T1J	4C	85°C
ADM1032ARM-1	0°C to 120°C	8-Lead MSOP	RM-8	T1A	4C	108°C
ADM1032ARM-1REEL	0°C to 120°C	8-Lead MSOP	RM-8	T1A	4C	108°C
ADM1032ARM-1REEL7	0°C to 120°C	8-Lead MSOP	RM-8	T1A	4C	108°C
ADM1032ARMZ-1 <sup>1</sup>	0°C to 120°C	8-Lead MSOP	RM-8	T13	4C	108°C
ADM1032ARMZ-1REEL <sup>1</sup>	0°C to 120°C	8-Lead MSOP	RM-8	T13	4C	108°C
ADM1032ARMZ-1REEL7 <sup>1</sup>	0°C to 120°C	8-Lead MSOP	RM-8	T13	4C	108°C
ADM1032ARMZ-2 <sup>1</sup>	0°C to 120°C	8-Lead MSOP	RM-8	T1C	4D	85°C
ADM1032ARMZ-2REEL <sup>1</sup>	0°C to 120°C	8-Lead MSOP	RM-8	T1C	4D	85°C
ADM1032ARMZ-2REEL7 <sup>1</sup>	0°C to 120°C	8-Lead MSOP	RM-8	T1C	4D	85°C

<sup>1</sup> Z = Pb-free part.

**ADM1032**

**NOTES**