

LOC	DIST	REVISIONS			
P	LTR	DESCRIPTION	DATE	DWN	APVD
M1		REVISED PER ECR-21-118222	25-JUL-22	AIN	VS

- PARTS COMPLY TO AMP SOLDERABILITY SPECIFICATION 109-11-3.
- CIRCUIT IDENTIFICATION CHARACTERS ARE ADJACENT TO THE INDICATED CAVITIES, BUT LOCATION AND ORIENTATION MAY DIFFER FROM PRINT.
- DIMENSIONS IN BRACKETS ARE IN INCHES.
- DRAIN HOLES LOCATED AS SHOWN. OPTIONAL CONSTRUCTION- ALL DRAIN HOLES LOCATED 90° AS SHOWN IN DETAIL A.
- DIMENSIONS SHOWN REPRESENT PRODUCT IN DRY CONDITION. ADDITIONAL 2% GROWTH DUE TO END USE LOCATION MOISTURE ABSORPTION MAY OCCUR AND SHOULD BE ACCOUNTED FOR.

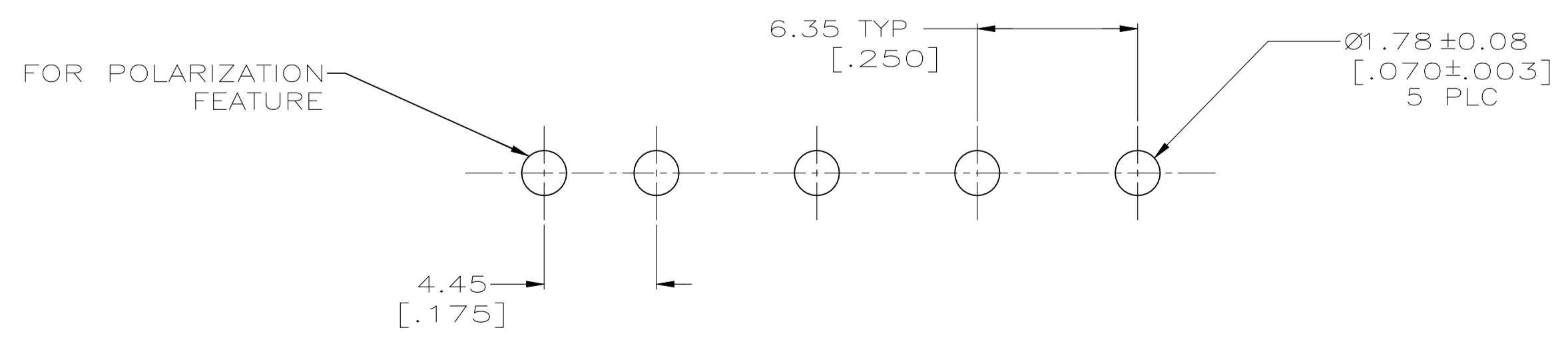

PHOSPHOR BRONZE, PRE-TIN	NYLON, UL94V-2, NATURAL	641967-1
PIN CONTACT MATERIAL AND FINISH	HOUSING MATERIAL	PART NO
THIS DRAWING IS A CONTROLLED DOCUMENT.		DWN L. McEACHIN 07-JAN-2000
DIMENSIONS: mm (INCHES)		CHK K. COBLE 07-JUN-2000
TOLERANCES UNLESS OTHERWISE SPECIFIED:		APVD K. COBLE 07-JUN-2000 NAME
0 PLC ±-	1 PLC ±-	PRODUCT SPEC
2 PLC ±0.13 [.005]	3 PLC ±-	APPLICATION SPEC
4 PLC ±-	ANGLES ±0° 30'	WEIGHT -
MATERIAL SEE TABLE	FINISH SEE TABLE	SCALE 5:1 SHEET 1 OF 1 REV M1
CUSTOMER DRAWING		SIZE CAGE CODE DRAWING NO
		A1 00779 641967

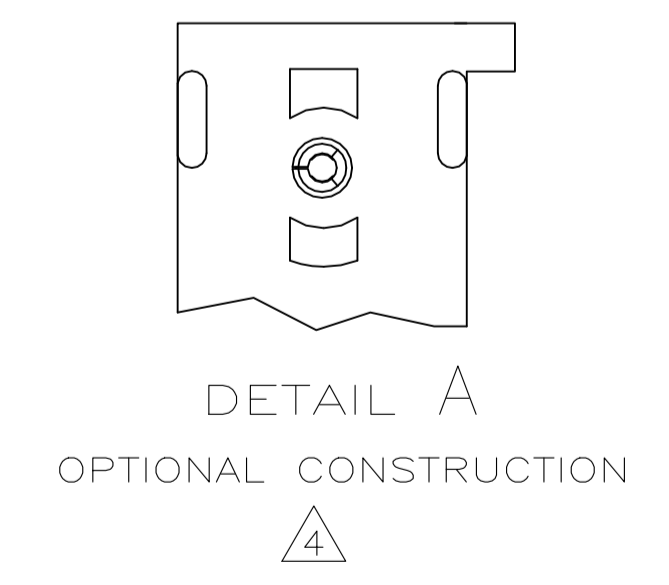
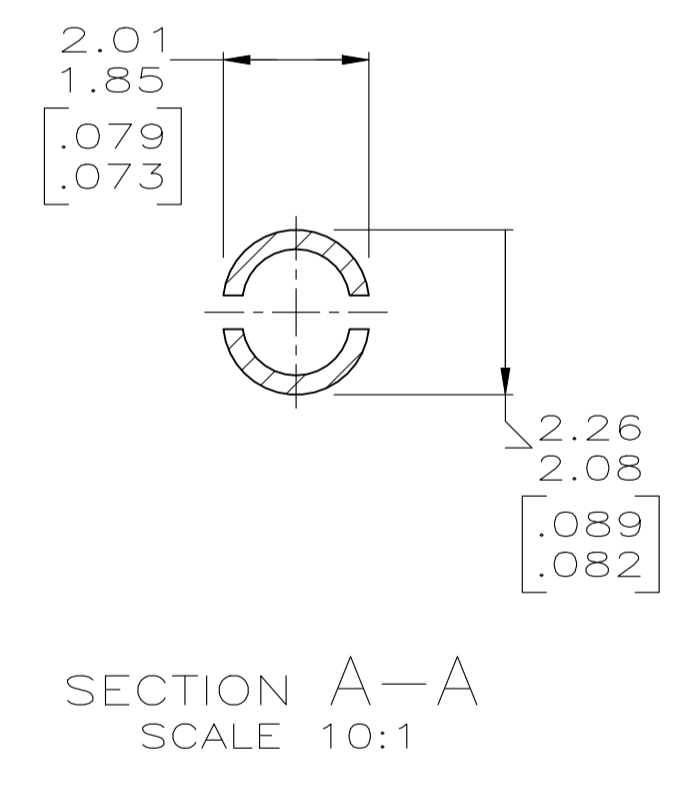
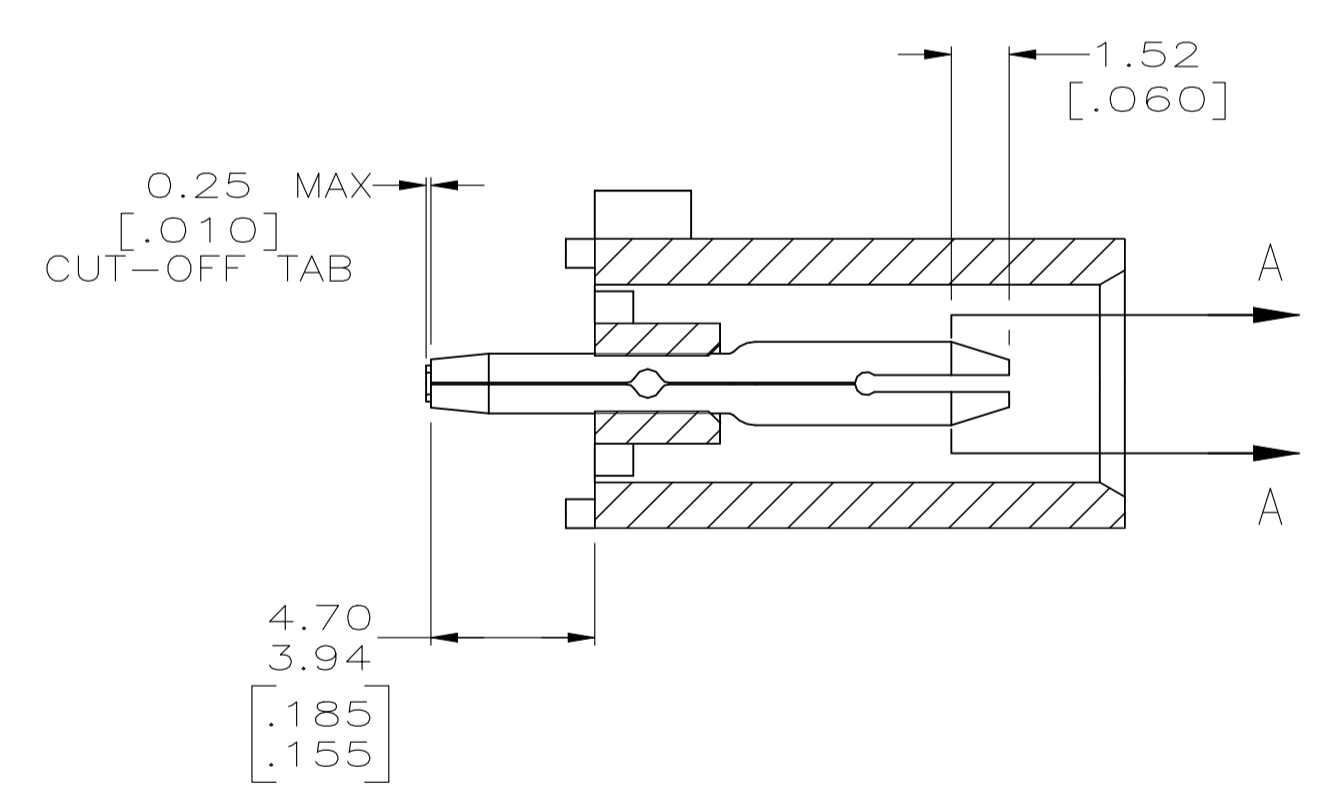
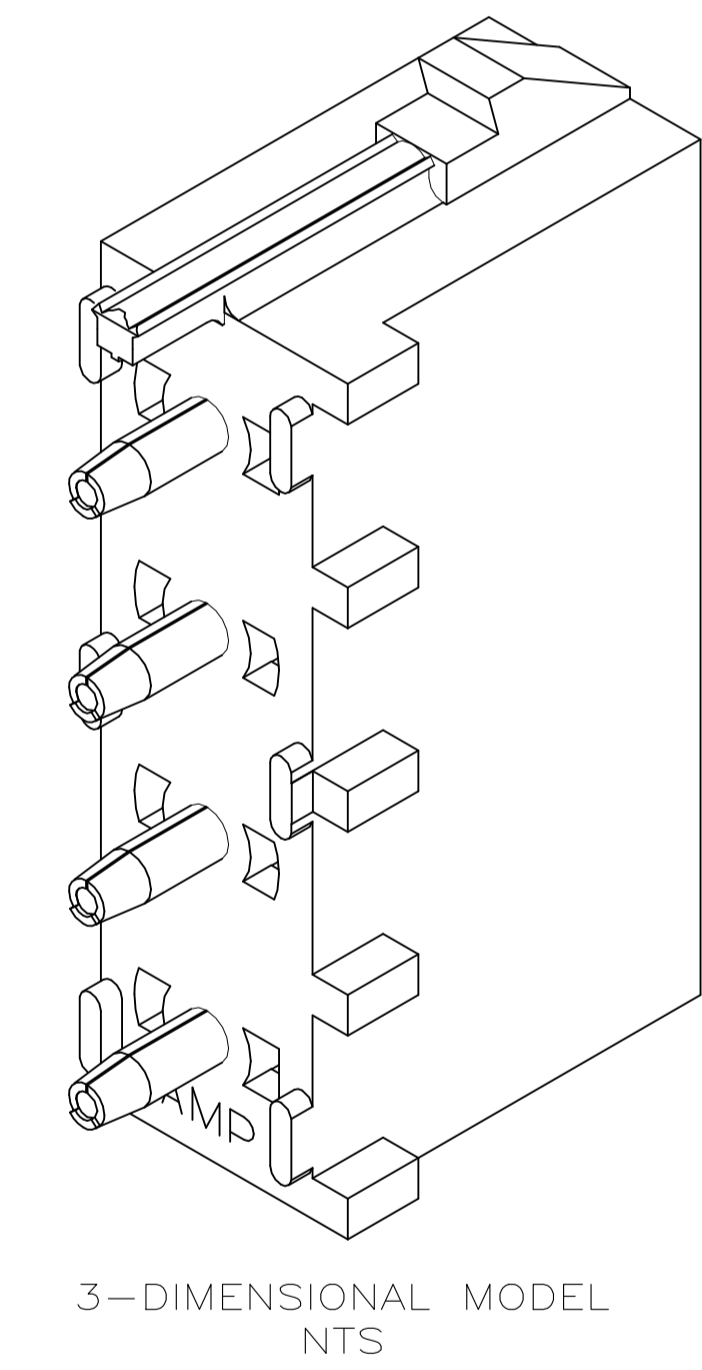
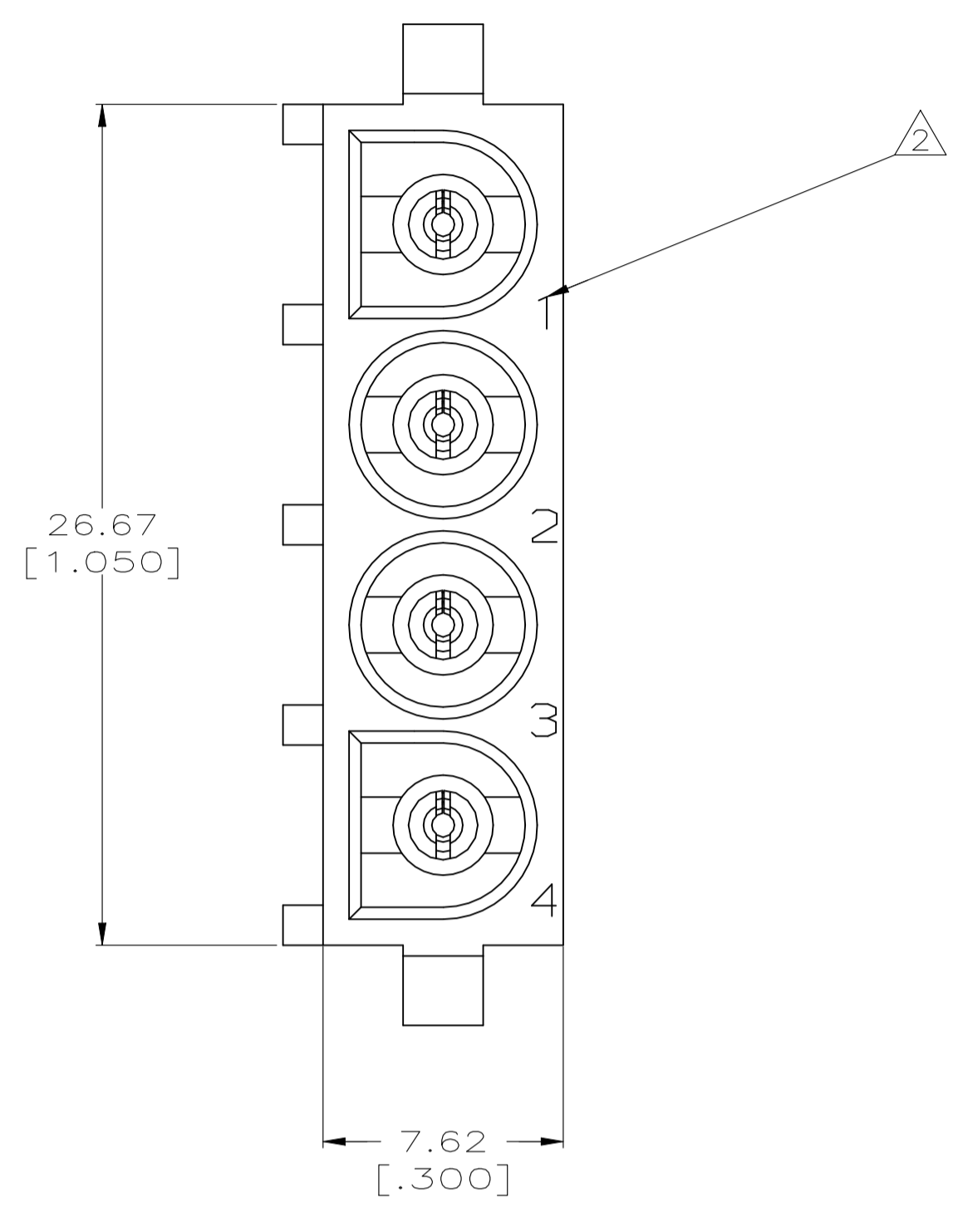
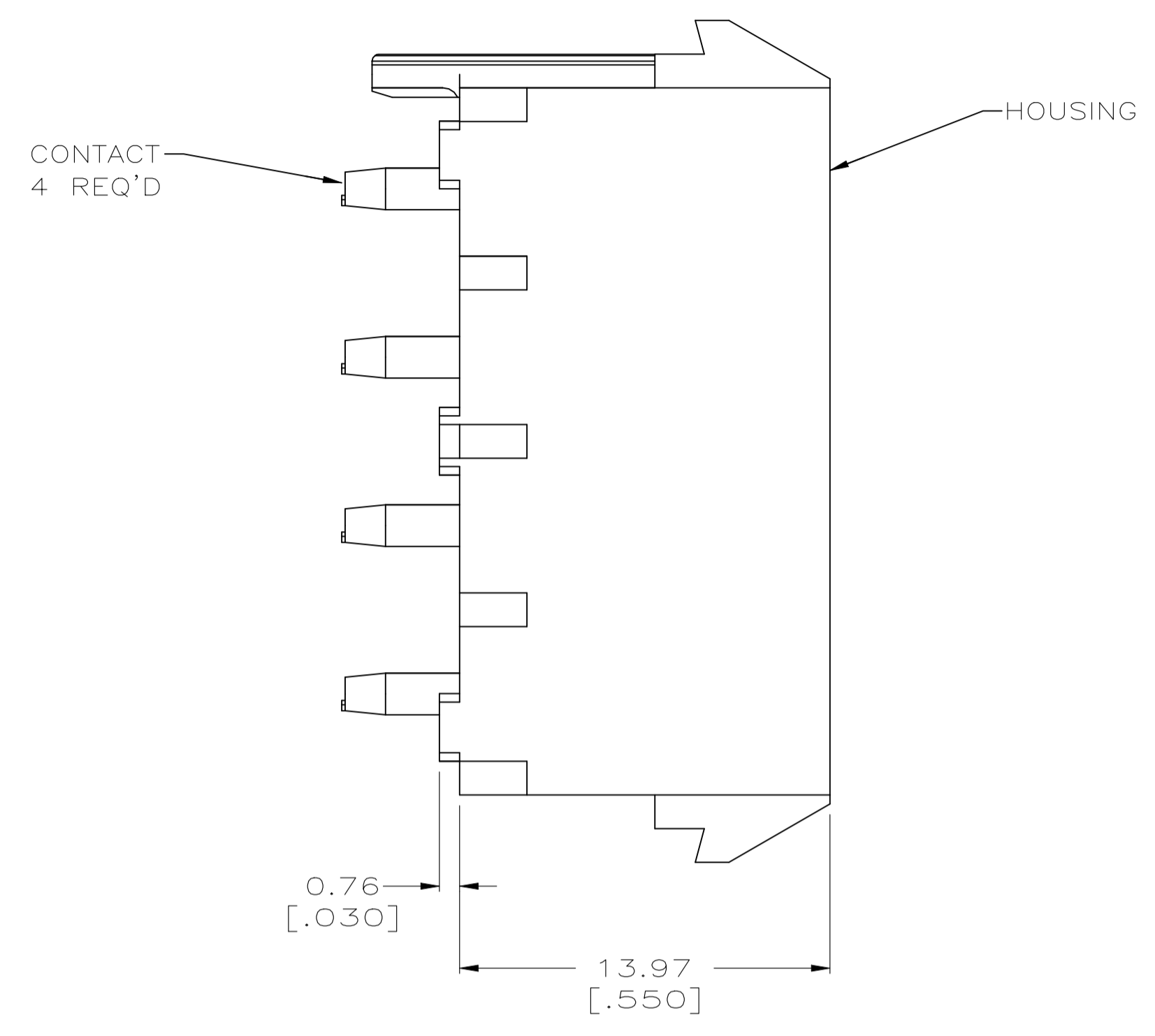
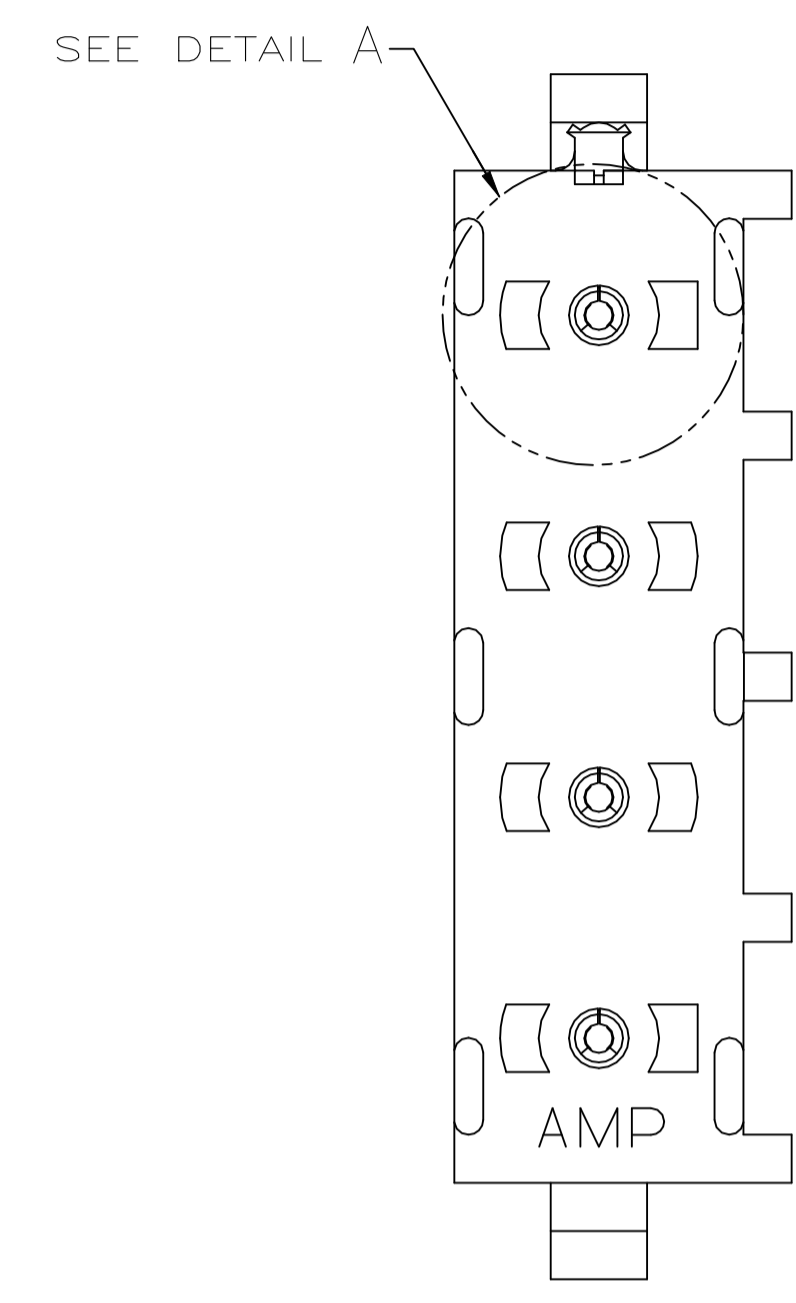