

## Datasheet

Visible Laser Device for Aligning Light Screen Systems



- Self-contained visible-beam laser tool simplifies the alignment of any opposed-mode sensor pair, especially in applications that include long distances or corner mirrors
- Reduces the time required to align light screen systems and corner mirrors; eliminates much trial-and-error guesswork when working with infrared beams
- Uses one common 9-volt battery (included)
- Built-in circular bubble level
- One 4 × 4-inch square of high-grade retroreflective target material included for easy viewing of the laser spot at long distances
- Mounting clip (available separately or as part of a kit; see below) snaps squarely onto the housings of Banner safety light screen/grid emitters and receivers

## Models

Emitter/Receiver Housing	LAT-1 with Clip(s) Kit Model	Clip Only Model
EZ-SCREEN™ 14/30 and LS	LAT-1-SS	EZA-LAT-SS
EZ-SCREEN™ Type 2	LAT-1-LS	LSA-LAT-2
EZ-SCREEN™ LP	LAT-1-LP	LPA-LAT-2
SGS Safety Grid System	LAT-1-SGS	SGSA-LAT-2
S4B Safety Light Curtain	LAT-1-S4B	S4BA-LAT-SS
All of the Above	LAT-1	-
EZ-SCREEN™ Type 2 Heavy Duty	LAT-1-LSHD	LSHDA-LAT-2

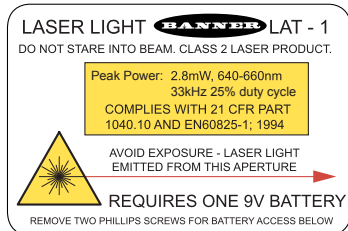

**CAUTION: Never stare directly into the sensor lens.** Laser light can damage your eyes. Avoid placing any mirror-like objects in the beam. View only the diffuse image of the laser beam where it strikes the alignment target. For more information, see Alignment Procedures in the appropriate product manual, which can be found by visiting <http://www.bannerengineering.com>. Failure to follow these guidelines can result in vision damage.

## Dimensions

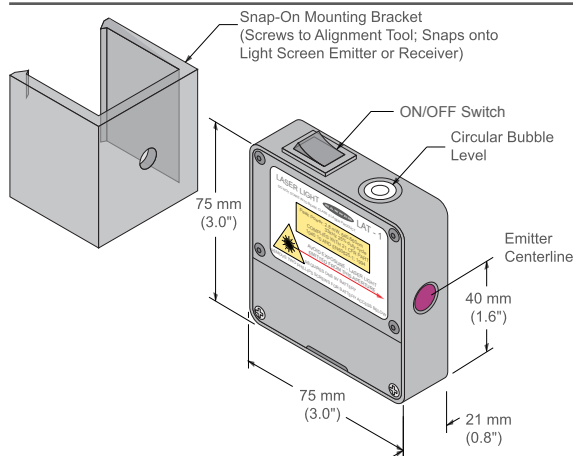

## Specifications

### Supply Voltage and Current

One standard 9 V battery, included (replaceable); approximately 20 hours of continuous operation

### Construction

Aluminum housing; black anodized finish  
Black polypropylene cover with flexible hinge for battery access

### Environmental Rating

NEMA 1; IEC IP50

### Operating Conditions

Temperature: 0° C to +40° C (+32° F to 104° F)  
Maximum Relative Humidity: 90% @ +50° C (non-condensing)

### Laser Classification

U.S. Safety Standards 21 CFR 1040.10  
European Standards EN 60825-1

### Sensing Beam

Class 2 laser, 640-660 nm visible red IEC  
Pulse Width: 7  $\mu$ s  
Rep Rate: 30  $\mu$ s  
Peak Output Power: 2.8 mW, 33kHz, 25% duty cycle

### Beam Size at Aperture

Approximately 2 mm (0.08 inch) diameter

### Beam Divergence

$\pm$  1.0 milliradian within specified temperature range  
 $\pm$  0.5 milliradians at room temperature

### Beam Placement

Within  $\pm$  4 milliradians (approximately  $\pm$  0.25 degrees) of parallel to front, back, top and bottom of housing

### Application Notes

See Caution on page 1 regarding safe use of laser beam.

## Alignment Procedure

To align a safety light screen using the LAT-1 follow these steps:

1. Mount all sensors and corner mirrors per the instructions in the appropriate manual. Leave the hardware slightly loose to allow for positioning adjustment.
2. Assemble the appropriate clip to the LAT-1; snap it onto the light screen emitter or receiver, and slide it to one end of the sensor. (HINT: Check the receiver for plumb first, before attaching the LAT-1 to the emitter for alignment.) Attach a retroreflective target to the corresponding end of the opposite sensor.
3. If the sensors are mounted vertically, check the circular bubble level for plumb orientation.
4. Standing behind the Alignment Tool, view the retroreflective target from behind the sensor (see Figure 1). Adjust either or both sensors and/or the corner mirrors as needed to place the laser image at the desired spot on the opposite sensor.
5. Move the Alignment Tool and the retroreflective target to the opposite ends of the sensors and repeat step 4.
6. Repeat steps 4 and 5 until the image falls at the desired spot at both the top and bottom of the opposite sensor; then tighten all mounting hardware.

*Aligning a corner-mirror light screen application using the Laser Alignment Tool*

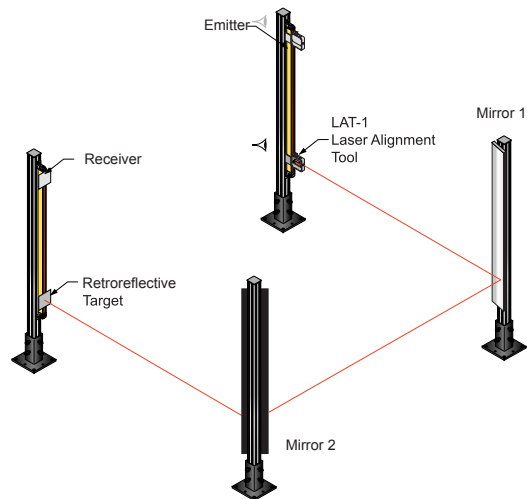

## Banner Engineering Corp. Limited Warranty

Banner Engineering Corp. warrants its products to be free from defects in material and workmanship for one year following the date of shipment. Banner Engineering Corp. will repair or replace, free of charge, any product of its manufacture which, at the time it is returned to the factory, is found to have been defective during the warranty period. This warranty does not cover damage or liability for misuse, abuse, or the improper application or installation of the Banner product.

**THIS LIMITED WARRANTY IS EXCLUSIVE AND IN LIEU OF ALL OTHER WARRANTIES WHETHER EXPRESS OR IMPLIED (INCLUDING, WITHOUT LIMITATION, ANY WARRANTY OF MERCHANTABILITY OR FITNESS FOR A PARTICULAR PURPOSE), AND WHETHER ARISING UNDER COURSE OF PERFORMANCE, COURSE OF DEALING OR TRADE USAGE.**

This Warranty is exclusive and limited to repair or, at the discretion of Banner Engineering Corp., replacement. **IN NO EVENT SHALL BANNER ENGINEERING CORP. BE LIABLE TO BUYER OR ANY OTHER PERSON OR ENTITY FOR ANY EXTRA COSTS, EXPENSES, LOSSES, LOSS OF PROFITS, OR ANY INCIDENTAL, CONSEQUENTIAL OR SPECIAL DAMAGES RESULTING FROM ANY PRODUCT DEFECT OR FROM THE USE OR INABILITY TO USE THE PRODUCT, WHETHER ARISING IN CONTRACT OR WARRANTY, STATUTE, TORT, STRICT LIABILITY, NEGLIGENCE, OR OTHERWISE.**

Banner Engineering Corp. reserves the right to change, modify or improve the design of the product without assuming any obligations or liabilities relating to any product previously manufactured by Banner Engineering Corp. Any misuse, abuse, or improper application or installation of this product or use of the product for personal protection applications when the product is identified as not intended for such purposes will void the product warranty. Any modifications to this product without prior express approval by Banner Engineering Corp will void the product warranties. All specifications published in this document are subject to change; Banner reserves the right to modify product specifications or update documentation at any time. Specifications and product information in English supersede that which is provided in any other language. For the most recent version of any documentation, refer to: [www.bannerengineering.com](http://www.bannerengineering.com).

For patent information, see [www.bannerengineering.com/patents](http://www.bannerengineering.com/patents).