

ON Semiconductor

Is Now

onsemi™

To learn more about onsemi™, please visit our website at
www.onsemi.com

onsemi and **onsemi** and other names, marks, and brands are registered and/or common law trademarks of Semiconductor Components Industries, LLC dba "**onsemi**" or its affiliates and/or subsidiaries in the United States and/or other countries. **onsemi** owns the rights to a number of patents, trademarks, copyrights, trade secrets, and other intellectual property. A listing of **onsemi** product/patent coverage may be accessed at www.onsemi.com/site/pdf/Patent-Marking.pdf. **onsemi** reserves the right to make changes at any time to any products or information herein, without notice. The information herein is provided "as-is" and **onsemi** makes no warranty, representation or guarantee regarding the accuracy of the information, product features, availability, functionality, or suitability of its products for any particular purpose, nor does **onsemi** assume any liability arising out of the application or use of any product or circuit, and specifically disclaims any and all liability, including without limitation special, consequential or incidental damages. Buyer is responsible for its products and applications using **onsemi** products, including compliance with all laws, regulations and safety requirements or standards, regardless of any support or applications information provided by **onsemi**. "Typical" parameters which may be provided in **onsemi** data sheets and/or specifications can and do vary in different applications and actual performance may vary over time. All operating parameters, including "Typicals" must be validated for each customer application by customer's technical experts. **onsemi** does not convey any license under any of its intellectual property rights nor the rights of others. **onsemi** products are not designed, intended, or authorized for use as a critical component in life support systems or any FDA Class 3 medical devices or medical devices with a same or similar classification in a foreign jurisdiction or any devices intended for implantation in the human body. Should Buyer purchase or use **onsemi** products for any such unintended or unauthorized application, Buyer shall indemnify and hold **onsemi** and its officers, employees, subsidiaries, affiliates, and distributors harmless against all claims, costs, damages, and expenses, and reasonable attorney fees arising out of, directly or indirectly, any claim of personal injury or death associated with such unintended or unauthorized use, even if such claim alleges that **onsemi** was negligent regarding the design or manufacture of the part. **onsemi** is an Equal Opportunity/Affirmative Action Employer. This literature is subject to all applicable copyright laws and is not for resale in any manner. Other names and brands may be claimed as the property of others.



ON Semiconductor®

**Strata Enabled
NCV8164A TSOP-5 Adjustable LDO EVB
User Guide**

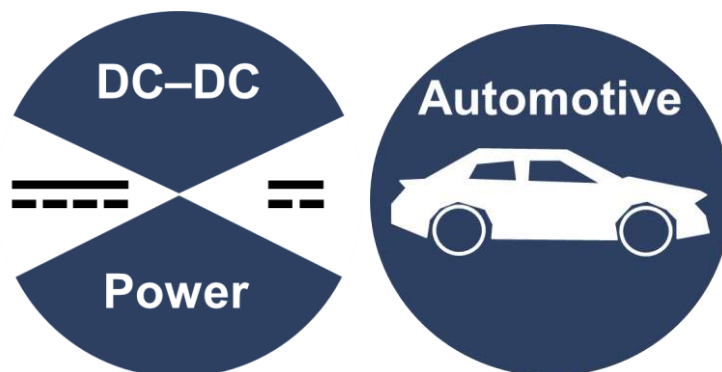

Table of Contents

| | |
|---|---|
| INTRODUCTION..... | 3 |
| Device Features | 3 |
| Applications..... | 3 |
| USER GUIDE | 4 |
| Hardware Setup | 4 |
| User Interface | 4 |
| Using Alternate LDO Package Options..... | 7 |
| Upstream Supply Voltage/LDO Input Voltage Options | 7 |
| Adjusting the LDO Input Voltage/Output Voltage/Load Current | 7 |

Introduction

The Strata Enabled NCV8164A TSOP-5 Adjustable LDO EVB provides an easy to use evaluation board within the Strata Developer Studio for the NCV8164A Adjustable LDO from ON Semiconductor. Through the Strata User Interface, the developer can access datasheets, BOMs, schematics, and other collateral they may need. This document will explain how to get the EVB up and running with Strata.

Device Features

- Operating Input Voltage Range:
 - 1.6 V to 5.5 V
- Adjustable Output Voltage Range:
 - 1.2V to 5V
- Reference Voltage: 1.2 V
 - $\pm 2\%$ Accuracy Over Load and Temperature
- Ultra Low Quiescent Current Typ. 30 μ A
- Standby Current: Typ. 0.1 μ A
- Very Low Dropout
- Ultra High PSRR: Typ. 85 dB at 10 mA, $f = 1$ kHz
- Ultra Low Noise
- Stable with a 1 μ F Small Case Size Ceramic Capacitors
- Package: TSOP-5 3 mm x 1.5 mm x 1 mm CASE 483
- Pb-Free, Halogen Free/BFR Free and RoHS Compliant

Applications

- Communication Systems
- In-Vehicle Networking
- Telematics, Infotainment and Clusters
- General Purpose Automotive

User Guide

This section will explain how to use the Strata Enabled NCV8164A TSOP-5 Adjustable LDO EVB in a step by step manner and will cover both the hardware required as well as how to use the User Interface (UI) in Strata. Please ensure that the latest version of Strata is installed before connecting to the board. The latest version can be downloaded from the ON Semiconductor [website](#).

Hardware Setup

The hardware required for using the Strata Enabled NCV8164A TSOP-5 Adjustable LDO EVB are a computer (with Windows), and power supply (5.5V voltage range recommended, 2A current limit or higher for short-circuit testing or 1A minimum for LDO output current up to 650mA). An external load can be connected to the output of the board but is not required. Follow the hardware setup steps below to get started:

1. Connect the computer to the EVB using the mini USB connector J26 on the bottom of the board.
2. Plug the power supply into the input of the board using the banana plugs J22 (positive terminal) and J24 (negative terminal). Do not hot plug the power cables or apply a voltage higher than the recommended input voltages in Table 1 to the input because this may damage circuitry on the board.
3. A picture of the setup can be found in Figure 1. The red power cables denote positive polarity with respect to the black power cables, which are connected to the board's common ground.

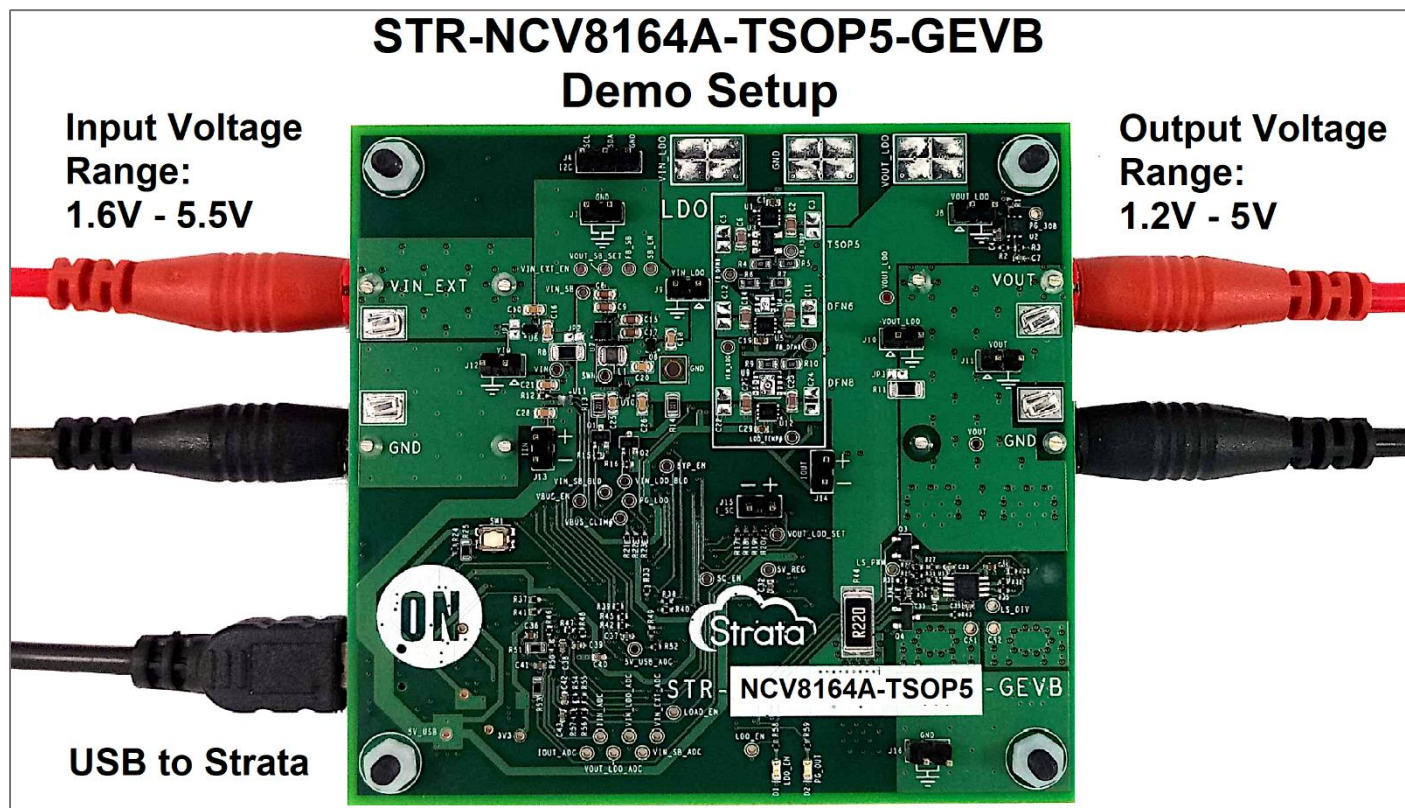

Figure 1: EVB demo setup

User Interface

The block diagram in Figure 2 provides an overview of the hardware included on this EVB. More information regarding the functionality of each block in the diagram can be found in the other documentation for the EVB included in the “Platform Content” page of the Strata UI.

Strata Enabled NCV8164A TSOP-5 Adjustable LDO EVB

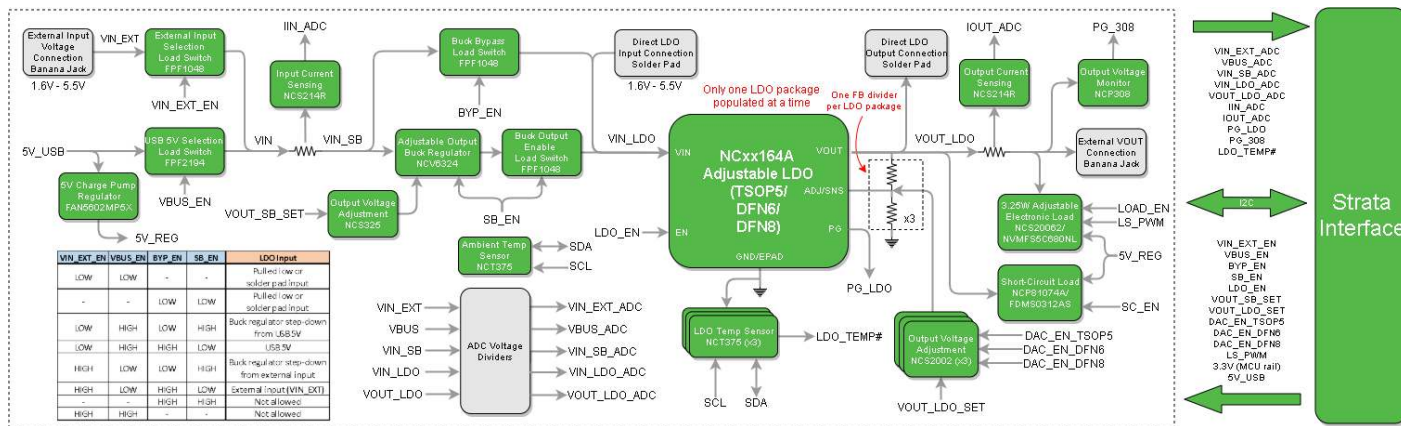

Figure 2: Block diagram of EVB

The “Platform Controls” page of the Strata UI allows you to control the LDO and monitor its telemetry. The steps below cover what is in the UI.

1. First, open the Strata Developer Studio application. The login page and home screen will appear.
2. Click the Register tab to create a new login if needed.
3. Once logged in, the app will automatically detect the device that is plugged in and will bring up the “Platform Controls” page of the Strata UI for the EVB.
4. The round button with a question mark in the top right corner is the Help button, and it will show the user what everything on the UI is doing.
5. Use the “Basic”, “Protection/Dropout”, and “System Efficiency” tabs at the top of the UI to switch between the different UI views, which provide different control and telemetry options. Note that all the controls available in the “Basic” view are also included in the “Protection/Dropout” and “System Efficiency” views.
6. The main “Basic” view that comes up (shown in Figure 3) offers basic telemetry, LDO upstream supply voltage selection, LDO package selection, LDO input voltage selection, LDO input/output voltage adjustment, LDO enable toggling, onboard load enable toggling, and onboard load current adjustment.

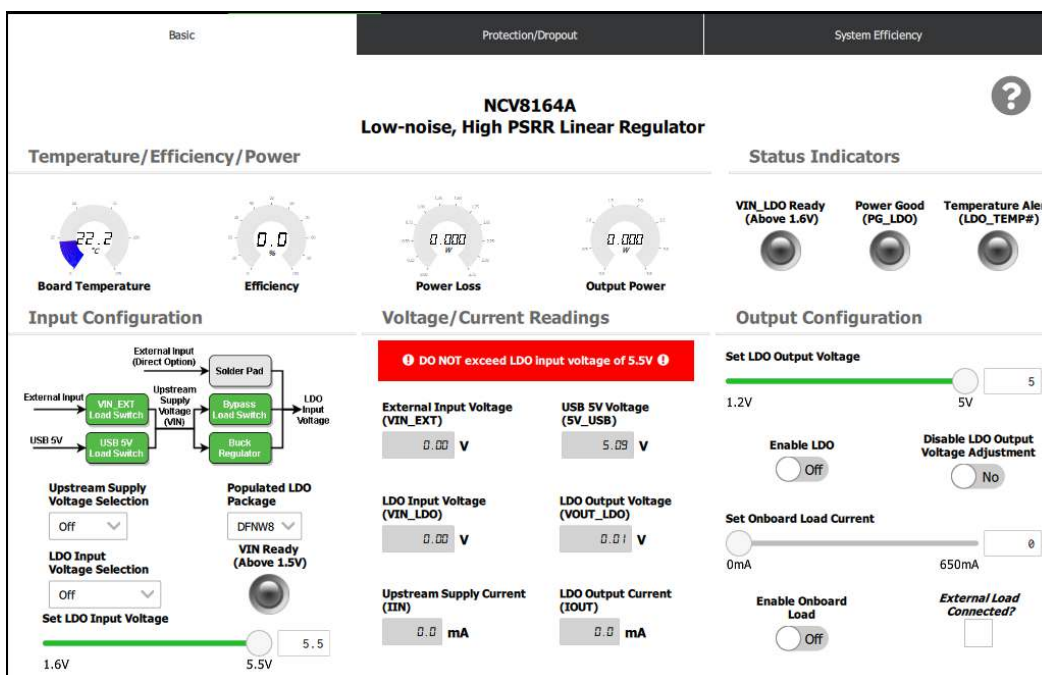

Figure 3: "Basic" UI view

- The “Protection/Dropout” view (shown in Figure 4) provides the ability to test the LDO’s current limit protection, TSD protection, and dropout voltage.

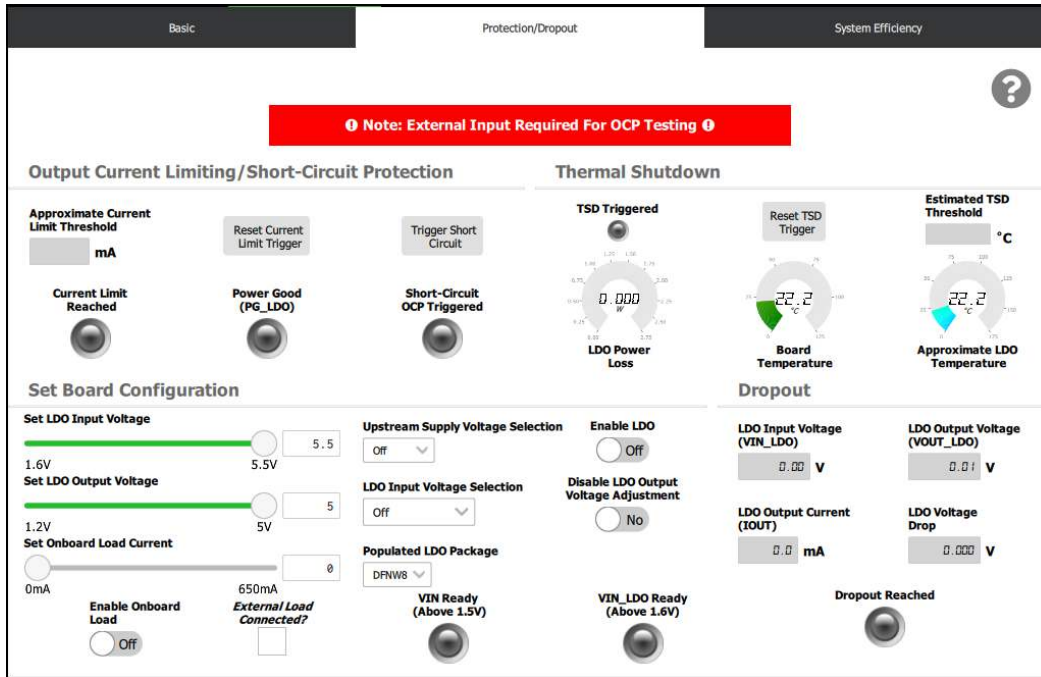

Figure 4: "Protection/Dropout" UI view

- The “System Efficiency” view (shown in Figure 5) can be used to evaluate the total efficiency of a buck regulator/LDO DC-DC step-down power distribution topology using the NCV6324 synchronous buck regulator included on the EVB.

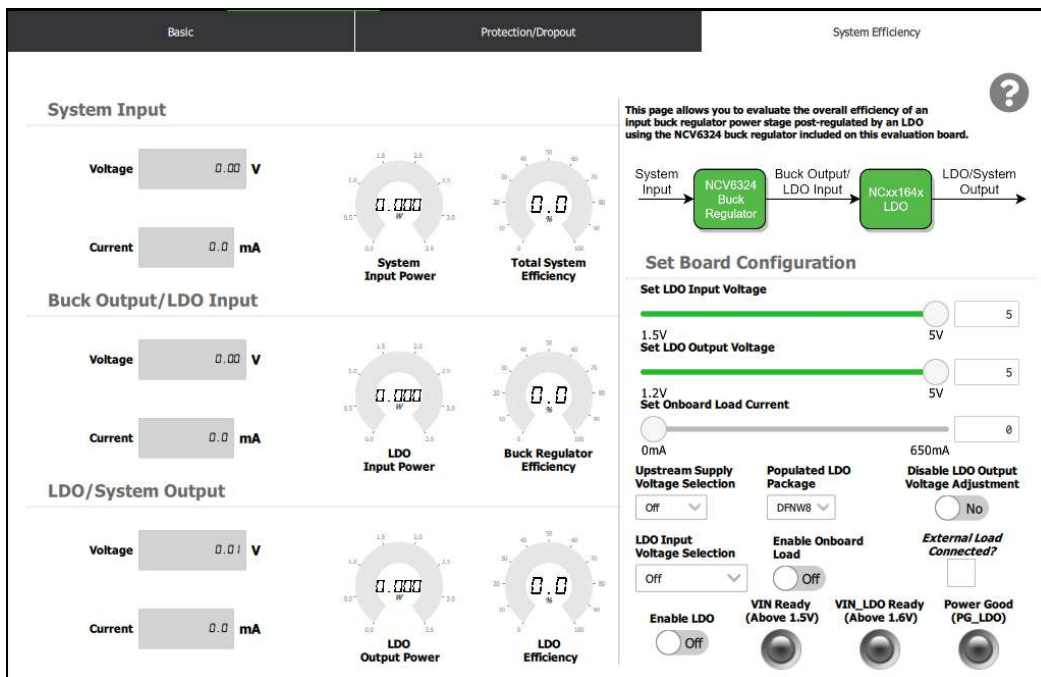

Figure 5: "System Efficiency" UI view

- To look at the collateral provided with the EVB, click on the “Platform Content” page at the top of the Strata UI.

Using Alternate LDO Package Options

The default LDO option included on this EVB is the NCV8164A in a TSOP-5 package; however, this EVB can support all available LDO package options for the NCV8164A (check the ON Semiconductor website, www.onsemi.com, for product availability). To use a different LDO package, the default package must be removed, and the new package must be installed manually. Do not install two or more LDO packages on the board at the same time. Auxiliary circuitry for all three packages is already included on the board so that the only component that needs to be replaced is the LDO. If using a different LDO package, ensure the correct package option is selected in the “Populated LDO Package” combo box in the UI. If the LDO package option selected in the UI does not match what is populated on the board, the LDO output voltage will not be adjustable and other telemetry/controls may not function properly.

Upstream Supply Voltage/LDO Input Voltage Options

Figure 6 shows a simplified power flow diagram demonstrating the various methods of powering the LDO on this EVB. Two upstream supply voltage options are provided: an external input voltage applied through the input banana plugs and 5V from the Strata USB connector. When using the external input as the upstream supply, the recommended input voltage range is 1.6V – 5.5V. The upstream supply voltage can then either be passed through to the LDO through a load switch or stepped down to an adjustable voltage with a buck regulator. Alternatively, a solder pad has been included on the board to bypass the input power stage of the EVB entirely and power the LDO directly from an external supply. This feature is intended to provide the direct evaluation of the LDO performance with minimal influence from the Strata telemetry and control circuitry. To use this feature, select the “Direct” option for the LDO input voltage in the UI. **CAUTION! Disconnect the external supply from the solder pad if changing the LDO input voltage option to the upstream supply voltage options (supplying from VIN).** The FPF1048 load switches used for bypassing or enabling the buck regulator input to the LDO do feature true reverse-current blocking and will shut off if VIN_LDO is greater than their input voltage while enabled, but they will not protect for cases where VIN_LDO is driven by an external source and VIN or VOUT_SB is greater than VIN_LDO (where large current draw from the upstream supply may occur). Damage to the components on the EVB and/or the external supply may result in either case. Regardless of the method used to supply power to the LDO, do not exceed the LDO’s absolute maximum input voltage rating of 6V.

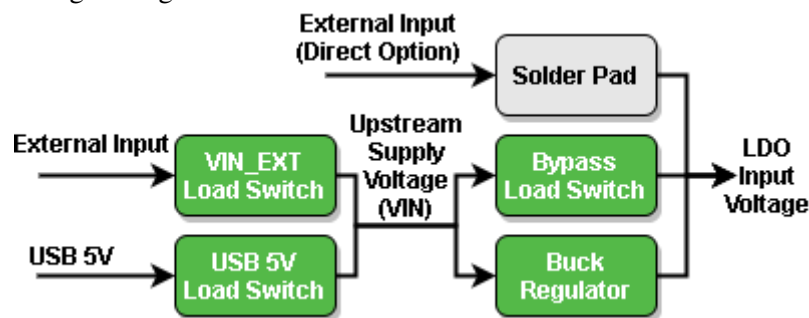

Figure 6: Simplified power flow diagram

Adjusting the LDO Input Voltage/Output Voltage/Load Current

When using the input buck regulator to supply power to the LDO, the LDO input voltage can be adjusted from 1.6V – 5.5V in 10mV steps using the “Set LDO Input Voltage” slider or input box in the UI with a typical accuracy $\leq 0.38\%$, assuming the input buck regulator’s input voltage (VIN_SB) is in the proper range (2.5V minimum). It is recommended to set the buck regulator output voltage under no load. The maximum output voltage of the buck regulator is automatically limited depending on the maximum input voltage of the LDO on the EVB. If the voltage setting in the UI is set higher than VIN_SB, the buck regulator output voltage setting will automatically be limited to

VIN_SB if the buck regulator is enabled. It is recommended not to adjust the buck regulator's input voltage lower than the output voltage setting in the UI while the buck regulator is enabled as this may result in temporary instability in the buck regulator output voltage. The Strata interface will attempt to remedy the instability by readjusting the output voltage setting of the buck regulator. If the instability is not resolved after a few seconds, try readjusting the buck regulator output voltage in the UI.

By default, the LDO output voltage can be adjusted from 1.2V – 5V in 10mV steps using the “Set LDO Output Voltage” slider or input box in the UI, with a typical accuracy $\leq 0.5\%$ across the entire range. The LDO output voltage adjustment circuit will adjust the output voltage to match the target voltage at the present output current load value (i.e. LDO load regulation is not accounted for), and as such, it is recommended to set the LDO output voltage under no load. Otherwise, the LDO output voltage may increase above the target value when the output load current decreases. In order to evaluate the LDO with fixed resistors to set the output voltage (as would be used in a typical application) and limit the output voltage noise contribution of the output voltage adjustment circuitry, the output voltage adjustment feature on the EVB can be disabled by turning on the “Disable LDO Output Voltage Adjustment” switch present in all the views. Note that the default resistors included with the EVB must be reinstalled in order to use the output voltage adjustment feature properly again. As with the buck regulator, the output voltage setting can be changed while the LDO is disabled and will be set to the desired value the next time the LDO is enabled. However, unlike the buck regulator, if the LDO output voltage is set greater than the LDO input voltage, the output voltage will not automatically be limited to VIN_LDO. This is done to enable the evaluation of the LDO's dropout voltage performance.

The onboard adjustable load on this EVB can pull a maximum load current of 650 mA down to a minimum VOUT of 1V, with a typical accuracy $\leq 3.5\%$ and $\sim 200\mu\text{A}$ resolution over the rated output current range of the LDO (0-300mA). The onboard load current can be adjusted using the “Set Onboard Load Current” slider or input box in the UI. An external load can be used in parallel with the onboard load, but make sure that if an external load is connected, the “External Load Connected?” checkbox in the UI is checked. The maximum onboard load current is limited to 300mA when powering the LDO via the 5V from the Strata USB connector. Do not pull more than 300mA with an external load if supplying the LDO through USB. Over-current protection for the USB 5V rail is implemented with the FPF2193 load switch with a threshold from 300mA to 500mA, 400mA nominal. If the onboard load is enabled but the sum of the external load current and target onboard load current is greater than 300mA, the onboard load will not be enabled. The output load current slider value can be adjusted while the onboard load and/or LDO is disabled, and the value will be set automatically when the load and LDO are both enabled again.

See the test report for this EVB for plots of LDO input voltage, LDO output voltage, and onboard load current accuracy over their full ranges.

ON Semiconductor and the ON Semiconductor logo are trademarks of Semiconductor Components Industries, LLC dba ON Semiconductor or its subsidiaries in the United States and/or other countries. ON Semiconductor owns the rights to a number of patents, trademarks, copyrights, trade secrets, and other intellectual property. A listing of ON Semiconductor's product/patent coverage may be accessed at www.onsemi.com/site/pdf/Patent-Marketing.pdf. ON Semiconductor is an Equal Opportunity/Affirmative Action Employer. This literature is subject to all applicable copyright laws and is not for resale in any manner.

The evaluation board/kit (research and development board/kit) (hereinafter the "board") is not a finished product and is as such not available for sale to consumers. The board is only intended for research, development, demonstration and evaluation purposes and should as such only be used in laboratory/development areas by persons with an engineering/technical training and familiar with the risks associated with handling electrical/mechanical components, systems and subsystems. This person assumes full responsibility/liability for proper and safe handling. Any other use, resale or redistribution for any other purpose is strictly prohibited.

The board is delivered "AS IS" and without warranty of any kind including, but not limited to, that the board is production-worthy, that the functions contained in the board will meet your requirements, or that the operation of the board will be uninterrupted or error free. ON Semiconductor expressly disclaims all warranties, express, implied or otherwise, including without limitation, warranties of fitness for a particular purpose and non-infringement of intellectual property rights.

ON Semiconductor reserves the right to make changes without further notice to any board.

You are responsible for determining whether the board will be suitable for your intended use or application or will achieve your intended results. Prior to using or distributing any systems that have been evaluated, designed or tested using the board, you agree to test and validate your design to confirm the functionality for your application. Any technical, applications or design information or advice, quality characterization, reliability data or other services provided by ON Semiconductor shall not constitute any representation or warranty by ON Semiconductor, and no additional obligations or liabilities shall arise from ON Semiconductor having provided such information or services.

The boards are not designed, intended, or authorized for use in life support systems, or any FDA Class 3 medical devices or medical devices with a similar or equivalent classification in a foreign jurisdiction, or any devices intended for implantation in the human body. Should you purchase or use the board for any such unintended or unauthorized application, you shall indemnify and hold ON Semiconductor and its officers, employees, subsidiaries, affiliates, and distributors harmless against all claims, costs, damages, and expenses, and reasonable attorney fees arising out of, directly or indirectly, any claim of personal injury or death associated with such unintended or unauthorized use, even if such claim alleges that ON Semiconductor was negligent regarding the design or manufacture of the board.

This evaluation board/kit does not fall within the scope of the European Union directives regarding electromagnetic compatibility, restricted substances (RoHS), recycling (WEEE), FCC, CE or UL, and may not meet the technical requirements of these or other related directives.

FCC WARNING – This evaluation board/kit is intended for use for engineering development, demonstration, or evaluation purposes only and is not considered by ON Semiconductor to be a finished end product fit for general consumer use. It may generate, use, or radiate radio frequency energy and has not been tested for compliance with the limits of computing devices pursuant to part 15 of FCC rules, which are designed to provide reasonable protection against radio frequency interference. Operation of this equipment may cause interference with radio communications, in which case the user shall be responsible, at its expense, to take whatever measures may be required to correct this interference.

ON Semiconductor does not convey any license under its patent rights nor the rights of others.

LIMITATIONS OF LIABILITY: ON Semiconductor shall not be liable for any special, consequential, incidental, indirect or punitive damages, including, but not limited to the costs of requalification, delay, loss of profits or goodwill, arising out of or in connection with the board, even if ON Semiconductor is advised of the possibility of such damages. In no event shall ON Semiconductor's aggregate liability from any obligation arising out of or in connection with the board, under any theory of liability, exceed the purchase price paid for the board, if any.

PUBLICATION ORDERING INFORMATION

LITERATURE FULLFILLMENT:

Literature Distribution Center for ON Semiconductor 19521 E.
32nd Pkwy, Aurora, Colorado 80011 USA

Phone: 303-675-2175 or 800-344-3860 Toll Free USA/Canada

Fax: 303-675-2176 or 800-344-3867 Toll Free USA/Canada

Email: orderlit@onsemi.com

N. American Technical Support:

800-282-9855 Toll Free USA/Canada

Europe, Middle East and Africa Technical Support:

Phone: 421 33 790 2910

ON Semiconductor Website:

<https://www.onsemi.com/>

Order Literature:

<https://www.onsemi.com/orderlit>

For additional information, please contact your local
Sales Representative