

Amphenol
FCI

© 2016 APCI

spec ref	*	dr	De-Ming Lu	2016/01/12	projection	MM	size	A2	scale	3:1	
tolerance std	ISO 406 ISO 1101	eng	De-Ming Lu	2016/07/07			ecn no	-	rel level		Released
TOLERANCES UNLESS OTHERWISE SPECIFIED		chr	Martin Li	2016/07/07			product family	PWRMAX			rev
surface	ISO 1302	linear	0.X	±0.5	Amphenol FCI		2HP WITH GUIDE PIN	cat. no.	-	Product - Customer Drw	sheet 1 of 4
		angular	0°	±2°	VERTICAL PRESS-FIT RECEPTACLE		cat. no.	-	Product - Customer Drw	sheet 1 of 4	

PDS: Rev :A

STATUS:Released

Printed: Jul 07, 2016

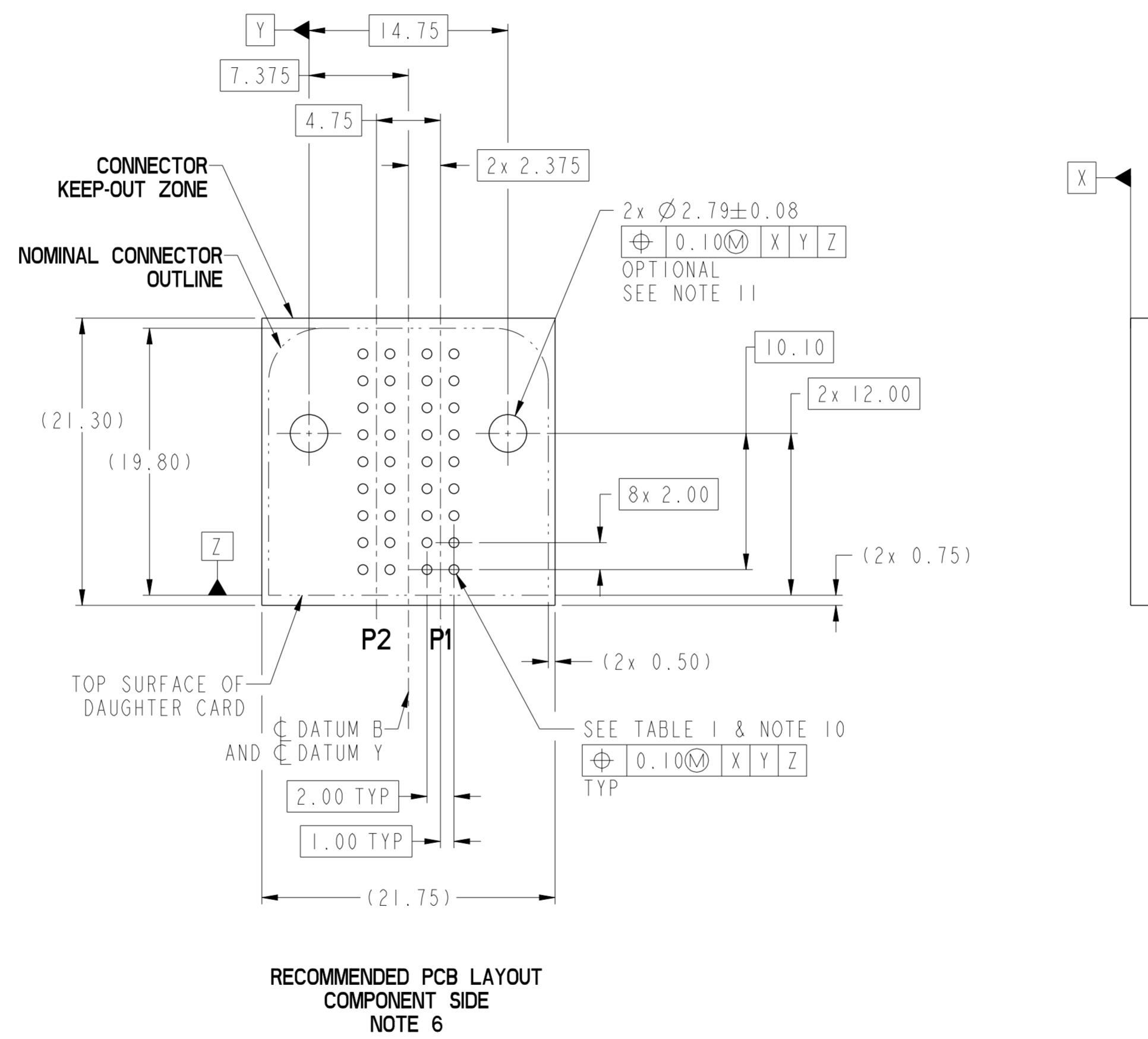

RECOMMENDED PCB LAYOUT
COMPONENT SIDE
NOTE 6

Amphenol
FCi

© 2016 AFci

spec ref	*	dr	De-Ming Lu	2016/01/12	projection	MM	size	A2	scale	3:1
tolerance std	ISO 406 ISO 1101	eng	De-Ming Lu	2016/07/07			ecn no	-	rel level	Released
TOLERANCES UNLESS OTHERWISE SPECIFIED		chr	Martin Li	2016/07/07						
surface	linear	0.X	±0.5	0.XX	±0.25	0.XXX	±0.100	Amphenol FCI		
ISO 1302	angular	0°	±2°	TITLE: 2HP WITH GUIDE PIN VERTICAL PRESS-FIT RECEPTACLE		cat. no.	-	Product - Customer Drw	sheet 2 of 4	

PDS: Rev :A

STATUS:Released

Printed: Jul 07, 2016

TOP LAYER DESCRIPTION	TABLE 1 (PWRMAX POWER) PLATED THROUGH-HOLE REQUIREMENTS							
	DRILLED HOLE DIAMETER	COPPER THICKNESS	TIN-LEAD THICKNESS	NICKEL THICKNESS	GOLD THICKNESS	TIN THICKNESS	SILVER THICKNESS	FINISHED HOLE DIAMETER
TIN-LEAD	0.81-0.86 (0.85 DRILL)	0.025 - 0.050	0.005 - 0.015	--	--	--	--	0.65 - 0.80
IMMERSION TIN	0.81-0.86 (0.85 DRILL)	0.025 - 0.050	--	--	--	0.9 - 1.5um	--	0.70 - 0.80
IMMERSION SILVER	0.81-0.86 (0.85 DRILL)	0.025 - 0.050	--	--	--	--	0.15 - 0.65um	0.70 - 0.80
COPPER (SEE NOTE 9)	0.81-0.86 (0.85 DRILL)	0.025 - 0.050	--	--	--	--	--	0.70 - 0.80
GOLD	0.81-0.86 (0.85 DRILL)	0.025 - 0.050	--	0.003 - 0.007	FLASH UP TO 0.0002	--	--	0.69 - 0.80

TOP LAYER DESCRIPTION	TABLE 2 (PWRMAX SIGNALS & LOW POWER) PLATED THROUGH-HOLE REQUIREMENTS							
	DRILLED HOLE DIAMETER	COPPER THICKNESS	TIN-LEAD THICKNESS	NICKEL THICKNESS	GOLD THICKNESS	TIN THICKNESS	SILVER THICKNESS	FINISHED HOLE DIAMETER
TIN-LEAD	1.125-1.175	0.025-0.050	0.005-0.015	--	--	--	--	0.94 - 1.10
IMMERSION TIN	1.125-1.175	0.025-0.050	--	--	--	0.9 - 1.5um	--	0.94 - 1.10
IMMERSION SILVER	1.125-1.175	0.025-0.050	--	--	--	--	0.15 - 0.65um	0.94 - 1.10
COPPER (SEE NOTE 9)	1.125-1.175	0.025-0.050	--	--	--	--	--	0.94 - 1.10
GOLD	1.125-1.175	0.025-0.050	--	0.003 - 0.007	FLASH UP TO 0.0002	--	--	0.93 - 1.10

Amphenol FCI

© 2016 APCI

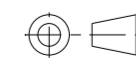
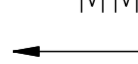
spec ref	*	dr	De-Ming Lu	2016/01/12	projection	MM	size	A2	scale	3:1		
tolerance std	ISO 406 ISO 1101	eng	De-Ming Lu	2016/07/07			ecn no	-	rel level		Released	
surface	TOLERANCES UNLESS OTHERWISE SPECIFIED linear 0.X ±0.5 0.XX ±0.25 0.XXX ±0.100 angular 0° ±2°	chr	Martin Li	2016/07/07			product family	PWRMAX	cat. no.	-	Product - Customer Drw	sheet 3 of 4
		appr	Pai-Ming Zheng	2016/07/07			Amphenol FCI	2HP WITH GUIDE PIN VERTICAL PRESS-FIT RECEPTACLE	div no	10138366	rev	A

PART NUMBER	M2.5 SCREW NOTE 11	TAIL TYPE
10138366-001LF	OPTIONAL	PRESS-FIT

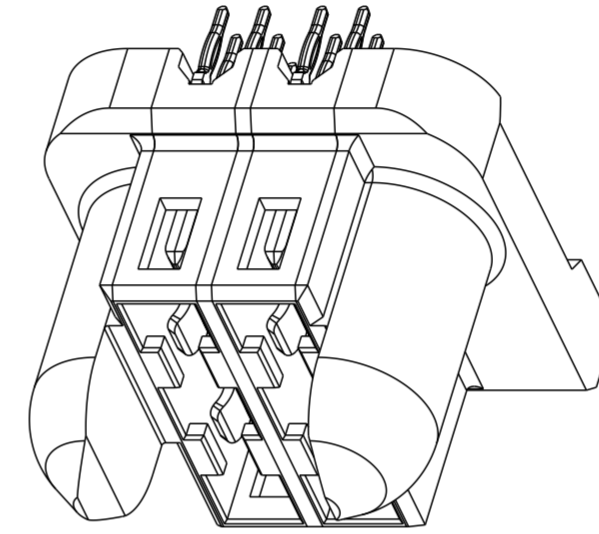

NOTES:

1. CONNECTOR MATERIALS:
HOUSING: HIGH TEMPERATURE THERMOPLASTIC, BLACK
UL 94V-0 COMPLIANT
CONTACTS: HIGH PERFORMANCE COPPER ALLOY
2. CONTACT FINISH (Ref to GS-12-1314 SECTION 5.2)
3. PRODUCT SPECIFICATION: GS-12-1314.
4. APPLICATION SPECIFICATION: GS-20-0447.
5. MANUFACTURER'S NAME, DATE CODE AND OPTIONAL P/N TO APPEAR ON THIS SURFACE. THE P/N CAN BE OMITTED IF THERE IS NOT ENOUGH SPACE ON THIS SURFACE.
6. MINIMUM NOMINAL PCB THICKNESS: 1.6mm
7. PACKAGED IN TUBES.
8. HOUSING COMPONENT WILL WITHSTAND EXPOSURE TO 260°C PEAK TEMPERATURE FOR 10 SECONDS IN A CONVECTION, INFRA-RED, OR VAPOR PHASE REFLOW OVEN.
9. COPPER PLATING THICKNESS IN CENTER OF VIA-HOLE CAN BE NO MORE THAN 0.003 LESS THAN OTHER AREAS.
10. ALL HOLE SIZES ARE FINISHED HOLE SIZES.
11. RECOMMENED RETENTION TO PCB:
Ø0.110[2.79] THRU HOLE (UNPLATED) FOR M2.5 SELF THREADING SCREW, MAX HEAD Ø0.177[4.50].
RECOMMENDED SCREW LENGTH 0.276[7.00] + PCB THICKNESS.
RECOMMENDED SCREW SEATING TO PCB TORQUE: 2-5 lbf-in (2300-5760 gf-cm).

spec ref	*	dr	De-Ming Lu	2016/01/12	projection	MM	size	A2	scale	3:1
tolerance std	ISO 406 ISO 1101	eng	De-Ming Lu	2016/07/07			ecn no	-		
TOLERANCES UNLESS OTHERWISE SPECIFIED		chr	Martin Li	2016/07/07			rel level	Released		
surface	linear	appr	Pei-Ming Zheng	2016/07/07	product family	PWRMAX	rel level	Released	cat. no.	-
	angular	Amphenol FCi		title	2HP WITH GUIDE PIN VERTICAL PRESS-FIT RECEPTACLE		divg no	10138366	rev	A
				cat. no.	-	Product - Customer Drw	sheet 4 of 4			

PDS: Rev :A

STATUS:Released

Printed: Jul 07, 2016

Amphenol
FCi

© 2016 AFCi