

ISL54228

High-Speed USB 2.0 (480Mbps)

**NOT RECOMMENDED FOR NEW DESIGNS  
NO RECOMMENDED REPLACEMENT**  
contact our Technical Support Center at  
1-888-INTERSIL or www.intersil.com/tsc

Operation (OVP)

FN7628  
Rev 0.00  
July 29, 2010

The ISL54228 is a single supply, dual SPST (Single Pole/Single Throw) switch that is configured as a DPST. It can operate from a single 2.7V to 5.25V supply. The part was designed for switching or isolating a USB high-speed source or a USB high-speed and full-speed source in portable battery powered products.

The 3.5Ω SPST switches were specifically designed to pass USB full speed and USB high speed data signals. They have high bandwidth and low capacitance to pass USB high speed data signals with minimal distortion. The device has two logic control pins (OE and LP) to control the SPST switches.

The ISL54228 has OVP detection circuitry on the COM pins to open the SPST switches when the voltage at these pins exceeds 3.8V or goes negative by -0.45V. It isolates fault voltages up to +5.25V or down to -5V from getting passed to the other-side of the switch, thereby protecting the USB down-stream transceiver.

The ISL54228 is available in 8 Ld 1.2mmx1.4mm μTQFN and 8 Ld 2mmx2mm TDFN packages. It operates over a temperature range of -40°C to +85°C.

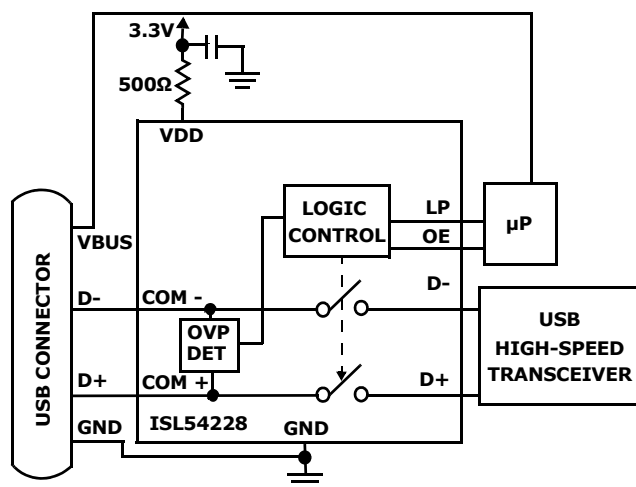
**Features**

- High-Speed (480Mbps) and Full-Speed (12Mbps) Signaling Capability per USB 2.0
- 1.8V Logic Compatible (2.7V to +3.6V Supply)
- Low Power State
- Power OFF Protection
- COM Pins Overvoltage Detection and Protection for +5.25V and -5V Fault Voltages
- -3dB Frequency . . . . . 790MHz
- Low ON Capacitance @ 240MHz . . . . . 2pF
- Low ON-Resistance . . . . . 3.5Ω
- Single Supply Operation (V<sub>DD</sub>) . . . . . 2.7V to 5.25V
- Available in μTQFN and TDFN Packages
- Pb-Free (RoHS Compliant)
- Compliant with USB 2.0 Short Circuit and Overvoltage Requirements Without Additional External Components

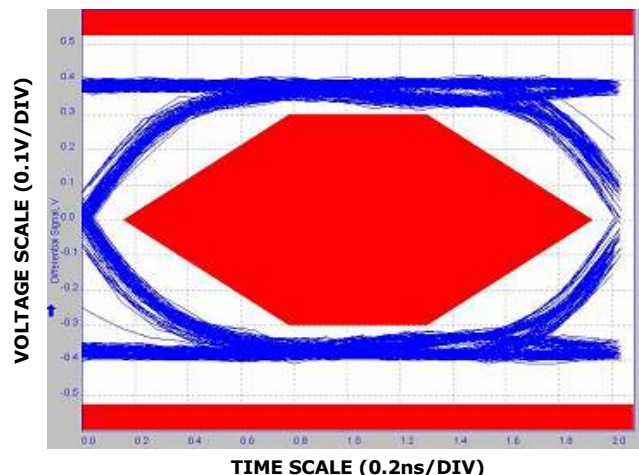
**Applications\*** (see page 15)

- MP3 and other Personal Media Players
- Cellular/Mobile Phones, PDAs
- Digital Cameras and Camcorders
- USB Switching

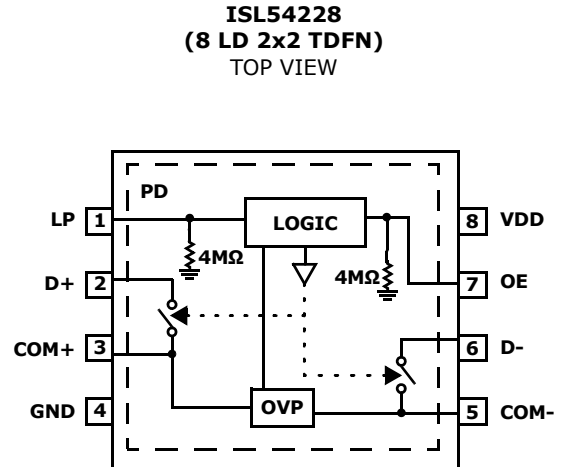
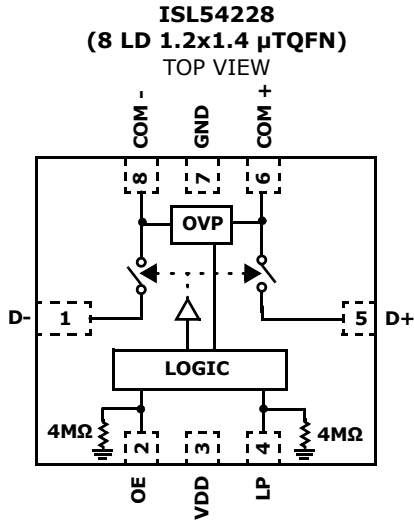
**Typical Application**



**USB 2.0 HS Eye Pattern with Switches in the Signal Path**



## Pin Configurations



NOTE: Switches Shown for OE = Logic "0".

## Pin Descriptions

$\mu$ TQFN	TDFN	PIN NAME	DESCRIPTION
4	1	LP	Low Power Input
5	2	D+	USB Data Port
6	3	COM+	USB Data Port
7	4	GND	Ground Connection
8	5	COM-	USB Data Port
1	6	D-	USB Data Port
2	7	OE	Switch Enable
3	8	VDD	Power Supply
-	PD	PD	Thermal Pad. Tie to Ground or Float

## Truth Table

INPUT			OUTPUT	
SIGNAL AT COM PINS	LP	OE	D-, D+	STATE
0V to 3.6V	0	0	OFF	Normal
0V to 3.6V	0	1	ON	Normal
0V to 3.6V	1	0	OFF	Low Power
0V to 3.6V	1	1	ON	Normal
Overvoltage Range	0	0	OFF	OVP
Overvoltage Range	0	1	OFF	OVP
Overvoltage Range	1	0	OFF	Neg OVP Limited Positive OVP No Persistence Checking Low Power
Overvoltage Range	1	1	OFF	OVP

NOTE: Logic "0" when  $\leq 0.5V$ , Logic "1" when  $\geq 1.4V$  with a 2.7V to 3.6V Supply.

**TABLE 1. USB - OVP POSSIBLE SITUATIONS AND TRIP POINT VOLTAGE**

CODEC SUPPLY	SWITCH SUPPLY (V <sub>DD</sub> )	COMS SHORTED TO	PROTECTED	TRIP POINT	
				MIN	MAX
2.7V to 3.3V	2.7V to 5.25V	VBUS	Yes	3.62V	3.95V
2.7V to 3.3V	2.7V to 5.25V	-5V	Yes	-0.6V	-0.29V

## Ordering Information

PART NUMBER	PART MARKING	TEMP. RANGE (°C)	PACKAGE (Pb-Free)	PKG. DWG. #
ISL54228IRUZ-T (Note 1, 3)	U6	-40 to +85	8 Ld 1.2mmx1.4mm $\mu$ TQFN (Tape and Reel)	L8.1.4x1.2
ISL54228IRUZ-T7A (Note 1, 3)	U6	-40 to +85	8 Ld 1.2mmx1.4mm $\mu$ TQFN (Tape and Reel)	L8.1.4x1.2
ISL54228IRTZ-T (Note 1, 2)	228	-40 to +85	8 Ld 2mmx2mm TDFN (Tape and Reel)	L8.2x2C
ISL54228IRTZ-T7A (Note 1, 2)	228	-40 to +85	8 Ld 2mmx2mm TDFN (Tape and Reel)	L8.2x2C
ISL54228IRUZEVAL1Z	Evaluation Board			

### NOTES:

1. Please refer to [TB347](#) for details on reel specifications.
2. These Pb-free plastic packaged products employ special Pb-free material sets, molding compounds/die attach materials, and 100% matte tin plate plus anneal (e3 termination finish, which is RoHS compliant and compatible with both SnPb and Pb-free soldering operations). Intersil Pb-free products are MSL classified at Pb-free peak reflow temperatures that meet or exceed the Pb-free requirements of IPC/JEDEC J STD-020.
3. These Pb-free plastic packaged products employ special Pb-free material sets; molding compounds/die attach materials and NiPdAu plate - e4 termination finish, which is RoHS compliant and compatible with both SnPb and Pb-free soldering operations. Pb-free products are MSL classified at Pb-free peak reflow temperatures that meet or exceed the Pb-free requirements of IPC/JEDEC J STD-020.
4. For Moisture Sensitivity Level (MSL), please see device information page for [ISL54228](#). For more information on MSL please see techbrief [TB363](#).

**Absolute Maximum Ratings**

VDD to GND	-0.3V to 6.5V
VDD to COMx	10.5V
COMx to Dx	8.6V
Input Voltages	
D+, D-	- 0.3V to 6.5V
COM+, COM-	- 5V to 6.5V
OE, LP	-0.3V to 6.5V
Continuous Current (COM-/D-, COM+/D+)	±40mA
Peak Current (COM-/D-, COM+/D+)	
(Pulsed 1ms, 10% Duty Cycle, Max)	±100mA
ESD Rating:	
Human Body Model (Tested per JESD22-A114-F)	>2kV
Machine Model (Tested per JESD22-A115-A)	>150V
Charged Device Model (Tested per JESD22-C101-D)	>2kV
Latch-up Tested per JEDEC; Class II Level A	at +85°C

**Thermal Information**

Thermal Resistance (Typical)	$\theta_{JA}$ (°C/W)	$\theta_{JC}$ (°C/W)
8 Ld $\mu$ TQFN Package (Note 6, 8)	210	165
8 Ld TDFN Package (Notes 5, 7)	96	19
Maximum Junction Temperature (Plastic Package)	+150°C	
Maximum Storage Temperature Range	-65°C to +150°C	
Pb-Free Reflow Profile	see link below	
	<a href="http://www.intersil.com/pbfree/Pb-FreeReflow.asp">http://www.intersil.com/pbfree/Pb-FreeReflow.asp</a>	

**Normal Operating Conditions**

Temperature Range	-40°C to +85°C
VDD Supply Voltage Range	2.7V to 5.25V
Logic Control Input Voltage	0V to 5.25V
Analog Signal Range	
VDD = 2.7V to 5.25V	0V to 3.6V

**CAUTION:** Do not operate at or near the maximum ratings listed for extended periods of time. Exposure to such conditions may adversely impact product reliability and result in failures not covered by warranty.

**NOTES:**

- $\theta_{JA}$  is measured in free air with the component mounted on a high effective thermal conductivity test board with "direct attach" features. See Tech Brief TB379.
- $\theta_{JA}$  is measured with the component mounted on a high effective thermal conductivity test board in free air. See Tech Brief TB379 for details.
- For  $\theta_{JC}$ , the "case temp" location is the center of the exposed metal pad on the package underside.
- For  $\theta_{JC}$ , the "case temp" location is taken at the package top center.

**Electrical Specifications - 2.7V to 5.25V Supply** Test Conditions: VDD = +3.3V, GND = 0V, VLP = GND, VOEH = 1.4V, VOEL = 0.5V, (Note 9), Unless Otherwise Specified. **Boldface limits apply over the operating temperature range, -40°C to +85°C.**

PARAMETER	TEST CONDITIONS	TEMP (°C)	MIN (Notes 10, 11)	TYP	MAX (Notes 10, 11)	UNITS
<b>ANALOG SWITCH CHARACTERISTICS</b>						
ON-Resistance, rON (High-Speed)	VDD = 2.7V, OE = 1.4V, IDX = 17mA, VCom+ or VCOM- = 0V to 400mV (see Figure 2, Note 14)	25	-	3.5	5	$\Omega$
		Full	-	-	<b>7</b>	$\Omega$
rON Matching Between Channels, $\Delta r_{ON}$ (High-Speed)	VDD = 2.7V, OE = 1.4V, IDX = 17mA, VCom+ or VCOM- = Voltage at max rON, (Notes 13, 14)	25	-	0.2	0.45	$\Omega$
		Full	-	-	<b>0.55</b>	$\Omega$
rON Flatness, RFLAT(ON) (High-Speed)	VDD = 2.7V, OE = 1.4V, IDX = 17mA, VCom+ or VCOM- = 0V to 400mV (Notes 12, 14)	25	-	0.26	1	$\Omega$
		Full	-	-	<b>1.2</b>	$\Omega$
ON-Resistance, rON	VDD = 3.3V, OE = 1.4V, ICOMX = 17mA, VCom+ or VCOM- = 3.3V (see Figure 2, Note 14)	+25	-	6.8	17	$\Omega$
		Full	-	-	<b>22</b>	$\Omega$
OFF Leakage Current, IDX(OFF)	VDD = 5.25V, OE = 0V, VDx = 0.3V, 3.3V, VCOMX = 3.3V, 0.3V	25	-20	1	20	nA
		Full	-	30	-	nA
ON Leakage Current, IDX(ON)	VDD = 5.25V, OE = 5.25V, VDx = 0.3V, 3.3V, VCOMX = 0.3V, 3.3V	25	-9	-	9	$\mu$ A
		Full	<b>-12</b>	-	<b>12</b>	$\mu$ A
Power OFF Leakage Current, ICOM+, ICOM-	VDD = 0V, VCOM+ = 5.25V, VCOM- = 5.25V, OE = 0V	25	-	-	11	$\mu$ A
Power OFF Logic Current, IOE	VDD = 0V, OE = 5.25V	25	-	-	22	$\mu$ A
Power OFF D+/D- Current, ID+, ID-	VDD = 0V, OE = VDD, VD+ = VD- = 5.25V	25	-	-	1	$\mu$ A

**Electrical Specifications - 2.7V to 5.25V Supply** Test Conditions:  $V_{DD} = +3.3V$ ,  $GND = 0V$ ,  $V_{LP} = GND$ ,  $V_{OE} = 1.4V$ ,  $V_{OEL} = 0.5V$ , (Note 9), Unless Otherwise Specified. **Boldface limits apply over the operating temperature range, -40°C to +85°C. (Continued)**

PARAMETER	TEST CONDITIONS	TEMP (°C)	MIN (Notes 10, 11)	TYP	MAX (Notes 10, 11)	UNITS
<b>OVERVOLTAGE PROTECTION DETECTION</b>						
Positive Fault-Protection Trip Threshold, $V_{PFP}$	$V_{DD} = 2.7V$ to $5.25V$ , $OE = V_{DD}$ (see Table 1 on page 3)	25	3.62	3.8	3.95	V
Negative Fault-Protection Trip Threshold, $V_{NFP}$	$V_{DD} = 2.7V$ to $5.25V$ , $OE = V_{DD}$ (see Table 1 on page 3)	25	-0.6	-0.45	-0.29	V
OFF Persistence Time Fault Protection Response Time	Negative OVP Response: $V_{DD} = 2.7V$ , $SEL = 0V$ or $V_{DD}$ , $OE = V_{DD}$ , $V_{Dx} = 0V$ to $-5V$ , $R_L = 15k\Omega$	25	-	102	-	ns
	Positive OVP Response: $V_{DD} = 2.7V$ , $SEL = 0V$ or $V_{DD}$ , $OE = V_{DD}$ , $V_{Dx} = 0V$ to $5.25V$ , $R_L = 15k\Omega$	25	-	2	-	$\mu s$
ON Persistence Time Fault Protection Recovery Time	$V_{DD} = 2.7V$ , $OE = V_{DD}$ , $V_{Dx} = 0V$ to $5.25V$ or $0V$ to $-5V$ , $R_L = 15k\Omega$	25	-	45	-	$\mu s$
<b>DYNAMIC CHARACTERISTICS</b>						
Turn-ON Time, $t_{ON}$	$V_{DD} = 3.3V$ , $V_{input} = 3V$ , $R_L = 50\Omega$ , $C_L = 50pF$ (see Figure 1)	25	-	160	-	ns
Turn-OFF Time, $t_{OFF}$	$V_{DD} = 3.3V$ , $V_{input} = 3V$ , $R_L = 50\Omega$ , $C_L = 50pF$ (see Figure 1)	25	-	60	-	ns
Skew, ( $t_{SKEWOUT} - t_{SKEWIN}$ )	$V_{DD} = 3.3V$ , $OE = 3.3V$ , $R_L = 45\Omega$ , $C_L = 10pF$ , $t_R = t_F = 500ps$ at 480Mbps, (Duty Cycle = 50%) (see Figure 5)	25	-	50	-	ps
Rise/Fall Degradation (Propagation Delay), $t_{pD}$	$V_{DD} = 3.3V$ , $OE = 3.3V$ , $R_L = 45\Omega$ , $C_L = 10pF$ , (see Figure 5)	25	-	250	-	ps
Crosstalk	$V_{DD} = 3.3V$ , $R_L = 50\Omega$ , $f = 240MHz$ (see Figure 4)	25	-	-39	-	dB
OFF-Isolation	$V_{DD} = 3.3V$ , $OE = 0V$ , $R_L = 50\Omega$ , $f = 240MHz$	25	-	-23	-	dB
-3dB Bandwidth	Signal = 0dBm, 0.2VDC offset, $R_L = 50\Omega$	25	-	790	-	MHz
OFF Capacitance, $C_{OFF}$	$f = 1MHz$ , $V_{DD} = 3.3V$ , $LP = 0V$ , $OE = 0V$ (Figure 3)	25	-	2.5	-	pF
COM ON Capacitance, $C_{(ON)}$	$f = 1MHz$ , $V_{DD} = 3.3V$ , $LP = 0V$ , $OE = 3.3V$ (Figure 3)	25	-	4	-	pF
COM ON Capacitance, $C_{(ON)}$	$f = 240MHz$ , $V_{DD} = 3.3V$ , $LP = 0V$ , $OE = 3.3V$	25	-	2	-	pF
<b>POWER SUPPLY CHARACTERISTICS</b>						
Power Supply Range, $V_{DD}$		Full	<b>2.7</b>		<b>5.25</b>	V
Positive Supply Current, $I_{DD}$	$V_{DD} = 5.25V$ , $OE = 5.25V$ , $LP = GND$	25	-	45	56	$\mu A$
		Full	-	-	<b>59</b>	$\mu A$
Positive Supply Current, $I_{DD}$	$V_{DD} = 3.6V$ , $OE = 3.6V$ , $LP = GND$	25	-	23	30	$\mu A$
		Full	-	-	<b>34</b>	$\mu A$
Positive Supply Current, $I_{DD}$ (Low Power State)	$V_{DD} = 3.6V$ , $OE = 0V$ , $LP = V_{DD}$	25	-	5	6	$\mu A$
		Full	-	-	<b>10</b>	$\mu A$
Positive Supply Current, $I_{DD}$	$V_{DD} = 4.3V$ , $OE = 2.6V$ , $LP = GND$	25	-	35	45	$\mu A$
		Full	-	-	<b>50</b>	$\mu A$

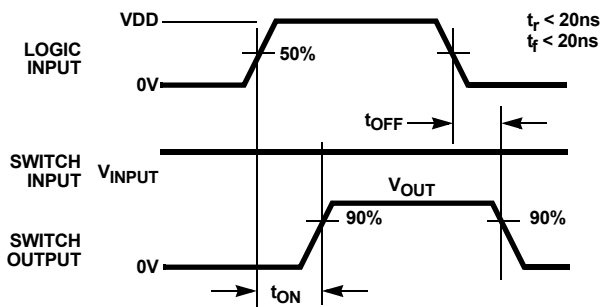
**Electrical Specifications - 2.7V to 5.25V Supply** Test Conditions:  $V_{DD} = +3.3V$ ,  $GND = 0V$ ,  $V_{LP} = GND$ ,  $V_{OEHigh} = 1.4V$ ,  $V_{OELow} = 0.5V$ , (Note 9), Unless Otherwise Specified. **Boldface limits apply over the operating temperature range, -40°C to +85°C. (Continued)**

PARAMETER	TEST CONDITIONS	TEMP (°C)	MIN (Notes 10, 11)	TYP	MAX (Notes 10, 11)	UNITS
Positive Supply Current, $I_{DD}$	$V_{DD} = 3.6V$ , $OE = 1.4V$ , $LP = GND$	25	-	25	32	$\mu A$
		Full	-	-	<b>38</b>	$\mu A$
<b>DIGITAL INPUT CHARACTERISTICS</b>						
Input Voltage Low, $V_{OEL}$ , $V_{LPL}$	$V_{DD} = 2.7V$ to $3.6V$	Full	-	-	<b>0.5</b>	V
Input Voltage High, $V_{OEHigh}$ , $V_{LPH}$	$V_{DD} = 2.7V$ to $3.6V$	Full	<b>1.4</b>	-	-	V
Input Voltage Low, $V_{OEL}$ , $V_{LPL}$	$V_{DD} = 3.7V$ to $4.2V$	Full	-	-	<b>0.7</b>	V
Input Voltage High, $V_{OEHigh}$ , $V_{LPH}$	$V_{DD} = 3.7V$ to $4.2V$	Full	<b>1.7</b>	-	-	V
Input Voltage Low, $V_{OEL}$ , $V_{LPL}$	$V_{DD} = 4.3V$ to $5.25V$	Full	-	-	<b>0.8</b>	V
Input Voltage High, $V_{OEHigh}$ , $V_{LPH}$	$V_{DD} = 4.3V$ to $5.25V$	Full	<b>2.0</b>	-	-	V
Input Current, $I_{OEL}$ , $I_{LPL}$	$V_{DD} = 5.25V$ , $OE = 0V$ , $LP = 0V$	Full	-	-8.2	-	nA
Input Current, $I_{OEHigh}$ , $I_{LPH}$	$V_{DD} = 5.25V$ , $OE = 5.25V$ , $LP = 5.25V$ , $4M\Omega$ Pull-down	Full	-	1.4	-	$\mu A$

NOTES:

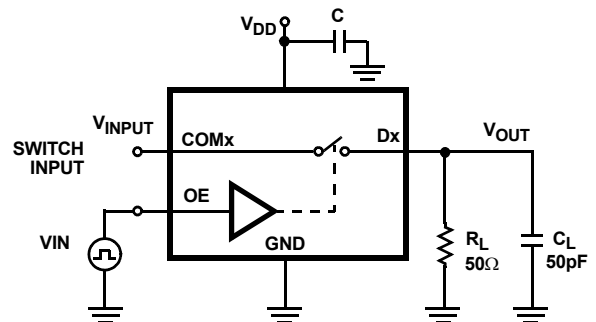
9.  $V_{LOGIC}$  = Input voltage to perform proper function.
10. The algebraic convention, whereby the most negative value is a minimum and the most positive a maximum, is used in this data sheet.
11. Parameters with MIN and/or MAX limits are 100% tested at +25°C, unless otherwise specified. Temperature limits established by characterization and are not production tested.
12. Flatness is defined as the difference between maximum and minimum value of ON-resistance over the specified analog signal range.
13.  $r_{ON}$  matching between channels is calculated by subtracting the channel with the highest max  $r_{ON}$  value from the channel with lowest max  $r_{ON}$  value.
14. Limits established by characterization and are not production tested.

**Test Circuits and Waveforms**



Logic input waveform is inverted for switches that have the opposite logic sense.

FIGURE 1A. MEASUREMENT POINTS



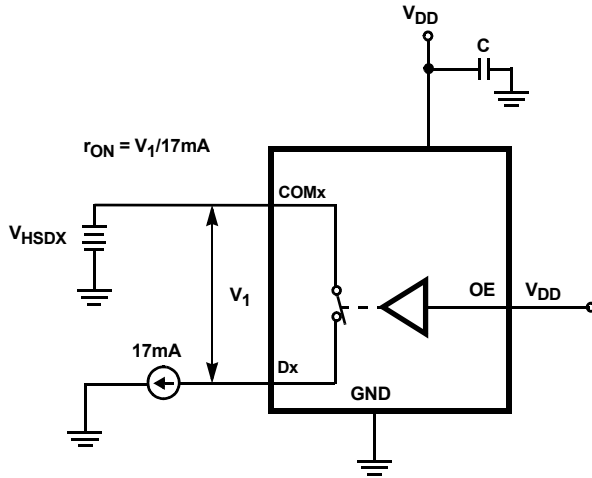
Repeat test for all switches.  $C_L$  includes fixture and stray capacitance.

$$V_{OUT} = V_{(INPUT)} \frac{R_L}{R_L + r_{ON}}$$

FIGURE 1B. TEST CIRCUIT

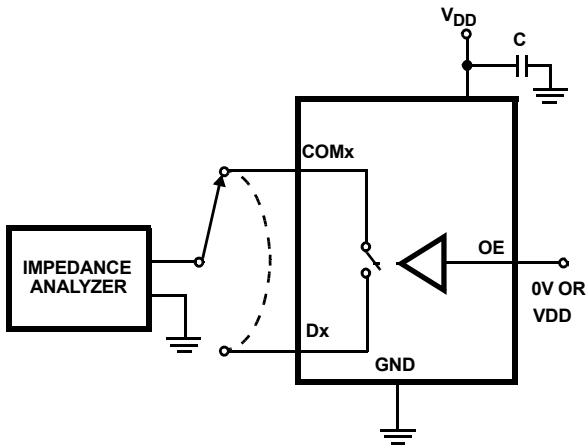
FIGURE 1. SWITCHING TIMES

**Test Circuits and Waveforms (Continued)**



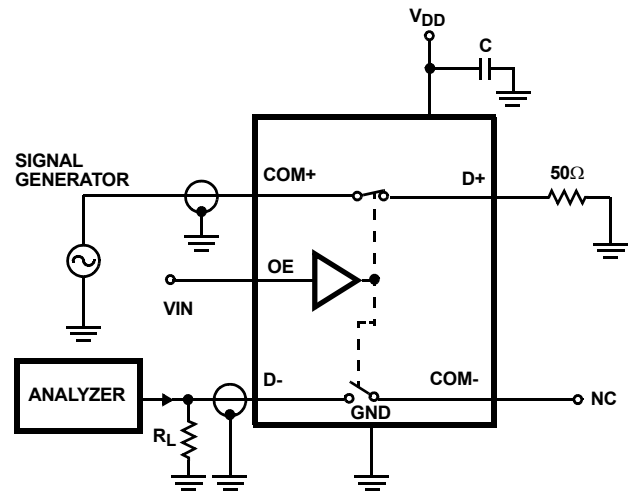
Repeat test for all switches.

**FIGURE 2. rON TEST CIRCUIT**



Repeat test for all switches.

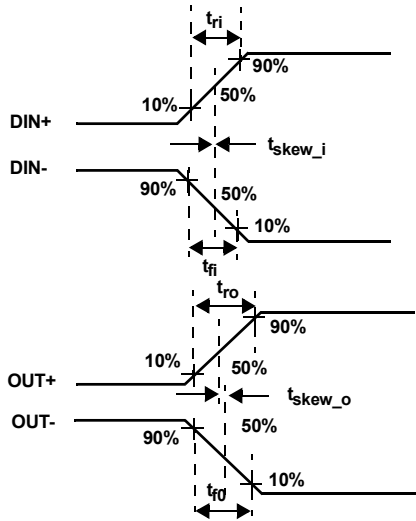
**FIGURE 3. CAPACITANCE TEST CIRCUIT**



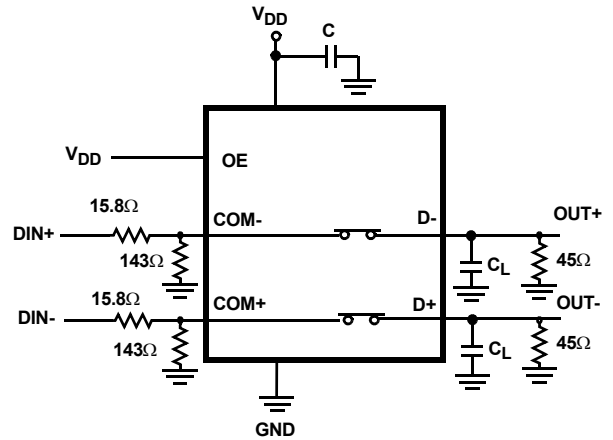
Signal direction through switch is reversed, worst case values are recorded. Repeat test for all switches.

**FIGURE 4. CROSSTALK TEST CIRCUIT**

**Test Circuits and Waveforms (Continued)**



**FIGURE 5A. MEASUREMENT POINTS**



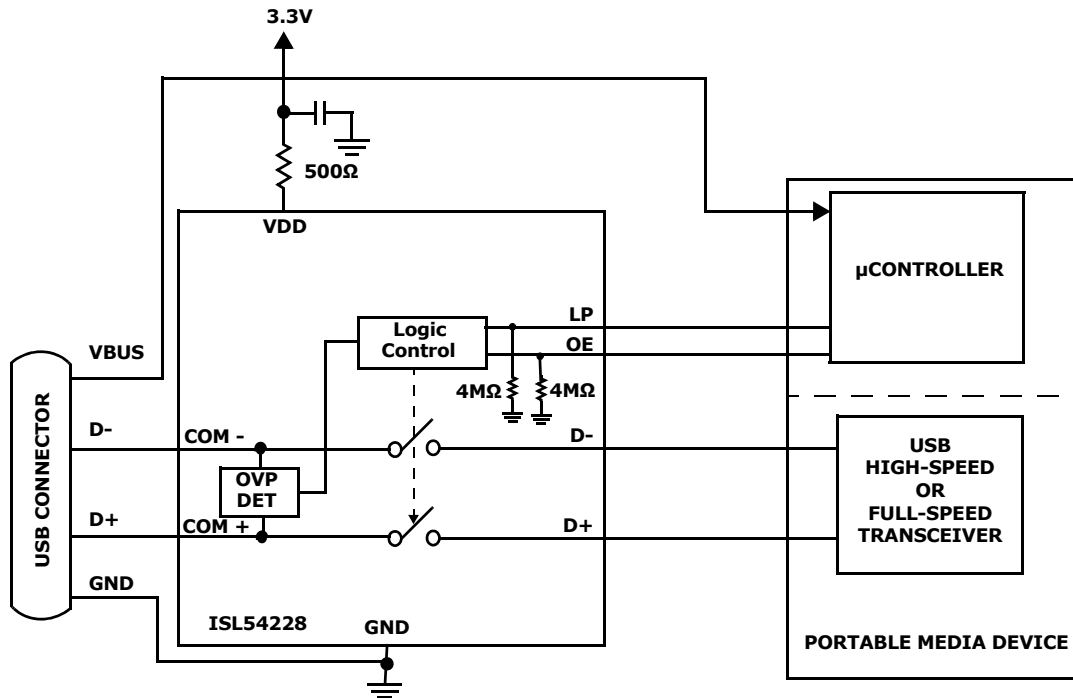
$|t_{ro} - t_{ri}|$  Delay Due to Switch for Rising Input and Rising Output Signals.  
 $|t_{fo} - t_{fi}|$  Delay Due to Switch for Falling Input and Falling Output Signals.  
 $|t_{skew_o}|$  Change in Skew through the Switch for Output Signals.  
 $|t_{skew_i}|$  Change in Skew through the Switch for Input Signals.

**FIGURE 5B. TEST CIRCUIT**

**FIGURE 5. SKEW TEST**



## Application Block Diagram



## Detailed Description

The ISL54228 device is a dual single pole/single throw (SPST) analog switch configured as a DPST that operates from a single DC power supply in the range of 2.7V to 5.25V.

It was designed for switching a USB high-speed source or full-speed source in portable battery powered products. It is offered in small  $\mu$ TQFN and TDFN packages for use in MP3 players, cameras, PDAs, cellphones, and other personal media players.

The part consists of two  $3.5\Omega$  high speed SPST switches. These switches have high bandwidth and low capacitance to pass USB high-speed (480Mbps) differential data signals with minimal edge and phase distortion. They can also swing from 0V to 3.6V to pass USB full speed (12Mbps) differential data signals with minimal distortion.

The device has a single logic control pin (OE) to open and close the two SPST switches. The part has an LP control pin to put the part in a low power state.

The part contains special overvoltage protection (OVP) circuitry on the COM+ and COM- pins. This circuitry acts to open the SPST switches when the part senses a voltage on the COM pins that is  $>3.8V$  (typ) or  $<-0.45V$  (typ). It isolates voltages up to 5.25V and down to -5V from getting through to the other side of the switches (D-, D+) to protect the USB down-stream transceiver connected at the D+ and D- pins.

The ISL54228 was designed for MP3 players, cameras, cellphones, and other personal media player

applications that need to switch a high-speed or full-speed transceiver source. A typical application block diagram of this functionality is previously shown.

A detailed description of the SPST switches is provided in the following section.

### High-Speed (Dx) SPST Switches

The Dx switches are bi-directional switches that can pass USB high-speed and USB full-speed signals when VDD is in the range of 2.7V to 5.25V.

When powered with a 2.7V supply, these switches have a nominal  $r_{ON}$  of  $3.5\Omega$  over the signal range of 0V to 400mV with a  $r_{ON}$  flatness of 0.26 $\Omega$ . The  $r_{ON}$  matching between the switches over this signal range is only 0.2 $\Omega$ , ensuring minimal impact by the switches to USB high speed signal transitions. As the signal level increases, the  $r_{ON}$  switch resistance increases. At a signal level of 3.3V, the switch resistance is nominally 9.8 $\Omega$ . See Figures 8, 9, 10, 11, 12, 13 in the "Typical Performance Curves" beginning on page 12.

The Dx switches were specifically designed to pass USB 2.0 high-speed (480Mbps) differential signals in the range of 0V to 400mV. They have low capacitance and high bandwidth to pass the USB high-speed signals with minimum edge and phase distortion to meet USB 2.0 high speed signal quality specifications. See Figure 14 in the "Typical Performance Curves" on page 13 for USB High-speed Eye Pattern taken with switch in the signal path.

The Dx switches can also pass USB full-speed signals (12Mbps) in the range of 0V to 3.6V with minimal

distortion and meet all the USB requirements for USB 2.0 full-speed signaling. See Figure 15 in the “Typical Performance Curves” on page 14 for USB Full-speed Eye Pattern taken with switch in the signal path.

The switches are active (turned ON) whenever the OE voltage is logic “1” (High) and the LP voltage is logic “X” (Don’t Care) and OFF when the OE voltage is logic “0” (Low) and the LP voltage is logic “X” (Don’t Care). When the OE voltage is logic “0” (Low) and the LP voltage is logic “1” (High) the part goes into low power mode.

**OVERVOLTAGE PROTECTION (OVP)**

The maximum normal operating signal range for the Dx switches is from 0V to 3.6V. For normal operation, the signal voltage should not be allowed to exceed these voltage levels or go below ground by more than -0.3V.

However, in the event that a positive voltage > 3.8V (typ) to 5.25V, such as the USB 5V  $V_{BUS}$  voltage, gets shorted to one or both of the COM+ and COM- pins or a negative voltage < -0.45V (typ) to -5V gets shorted to one or both of the COM pins, the ISL54228 has OVP circuitry to detect the overvoltage condition and open the SPST switches to prevent damage to the USB down-stream transceiver connected at the signal pins (D-, D+).

The OVP and power-off protection circuitry allows the COM pins (COM-, COM+) to be driven up to 5.25V while the  $V_{DD}$  supply voltage is in the range of 0V to 5.25V. In this condition, the part draws < 100 $\mu$ A of  $I_{COMx}$  and  $I_{DD}$  current and causes no stress to the IC. In addition, the SPST switches are OFF and the fault voltage is isolated from the other side of the switch.

**External  $V_{DD}$  Series Resistor to Limit  $I_{DD}$  Current During Negative OVP Condition**

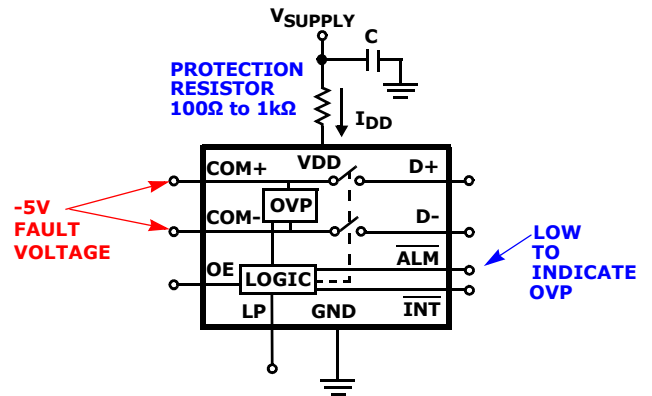
A 100 $\Omega$  to 1k $\Omega$  resistor in series with the VDD pin (see Figure 6) is required to limit the  $I_{DD}$  current draw from the system power supply rail during a negative OVP fault event.

With a negative -5V fault voltage at both COM pins, the graph in Figure 7 shows the  $I_{DD}$  current draw for different external resistor values for supply voltages of 5.25V, 3.6V, and 2.7V. Note: With a 500 $\Omega$  resistor, the current draw is limited to around 5mA. When the negative fault voltage is removed, the  $I_{DD}$  current will return to it’s normal operation current of 25 $\mu$ A to 45 $\mu$ A.

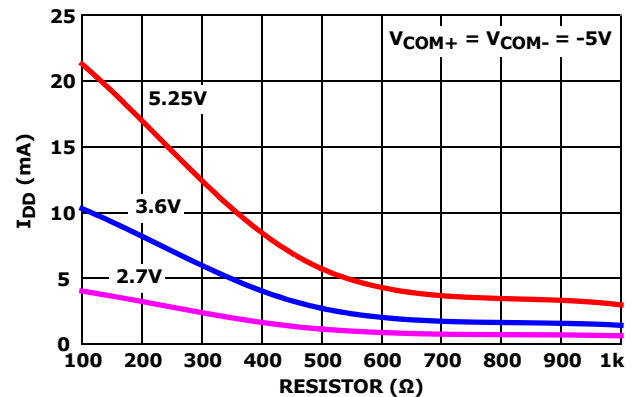
The series resistor also provides improved ESD and latch-up immunity. During an overvoltage transient event (such as occurs during system level IEC 61000 ESD testing), substrate currents can be generated in the IC that can trigger parasitic SCR structures to turn ON, creating a low impedance path from the VDD power supply to ground. This will result in a significant amount of current flow in the IC, which can potentially create a latch-up state or permanently damage the IC. The external VDD resistor limits the current during this over-stress

situation and has been found to prevent latch-up or destructive damage for many overvoltage transient events.

Under normal operation, the low microamp  $I_{DD}$  current of the IC produces an insignificant voltage drop across the series resistor resulting in no impact to switch operation or performance.



**FIGURE 6. VDD SERIES RESISTOR TO LIMIT  $I_{DD}$  CURRENT DURING NEGATIVE OVP AND FOR ENHANCED ESD AND LATCH-UP IMMUNITY**



**FIGURE 7. NEGATIVE OVP  $I_{DD}$  CURRENT vs RESISTOR VALUE vs  $V_{SUPPLY}$**

**ISL54228 Operation**

The following will discuss using the ISL54228 shown in the “Application Block Diagram” on page 9.

**POWER**

The power supply connected at the VDD pin provides the DC bias voltage required by the ISL54228 part for proper operation. The ISL54228 can be operated with a  $V_{DD}$  voltage in the range of 2.7V to 5.25V.

For lowest power consumption you should use the lowest  $V_{DD}$  supply.

A 0.01 $\mu$ F or 0.1 $\mu$ F decoupling capacitor should be connected from the VDD pin to ground to filter out any power supply noise from entering the part. The capacitor should be located as close to the VDD pin as possible.

In a typical application,  $V_{DD}$  will be in the range of 2.8V to 4.3V and will be connected to the battery or LDO of the portable media device.

### LOGIC CONTROL

The state of the ISL54228 device is determined by the voltage at the OE pin, LP pin, and the signal voltage at the COM pins. Refer to "Truth Table" on page 2.

The OE and LP pins are internally pulled low through a  $4M\Omega$  resistor to ground and can be tri-stated or left floating.

The ISL54228 is designed to minimize  $I_{DD}$  current consumption when the logic control voltage is lower than the  $V_{DD}$  supply voltage. With  $V_{DD} = 3.6V$  and the OE logic pin is at 1.4V, the part typically draws only  $25\mu A$ . With  $V_{DD} = 4.3V$  and the OE logic pin is at 2.6V, the part typically draws only  $35\mu A$ . Driving the logic pin to the  $V_{DD}$  supply rail minimizes power consumption.

The OE and LP pin can be driven with a voltage higher than the  $V_{DD}$  supply voltage. It can be driven up to 5.25V with a  $V_{DD}$  supply in the range of 2.7V to 5.25V.

**TABLE 2. LOGIC CONTROL VOLTAGE LEVELS**

$V_{DD}$ SUPPLY RANGE	LOGIC = "0" (LOW)		LOGIC = "1" (HIGH)	
	OE	LP	OE	LP
2.7V to 3.6V	$\leq 0.5V$ or floating	$\leq 0.5V$ or floating	$\geq 1.4V$	$\geq 1.4V$
3.7V to 4.2V	$\leq 0.7V$ or floating	$\leq 0.7V$ or floating	$\geq 1.7V$	$\geq 1.7V$
4.3V to 5.25V	$\leq 0.8V$ or floating	$\leq 0.8V$ or floating	$\geq 2.0V$	$\geq 2.0V$

### Low Power Mode

If the OE pin = Logic "0", and the LP pin = Logic "1" the switches will turn OFF (high impedance) and the part will be put in a low power mode. In this mode, the part draws only  $10\mu A$  (max) of current across the operating temperature range.

### Normal Operation Mode

With a signal level in the range of 0V to 3.6V and with the LP pin = Logic "0" the switches will be ON when the OE pin = Logic "1" and will be OFF (high impedance) when the OE pin = Logic "0".

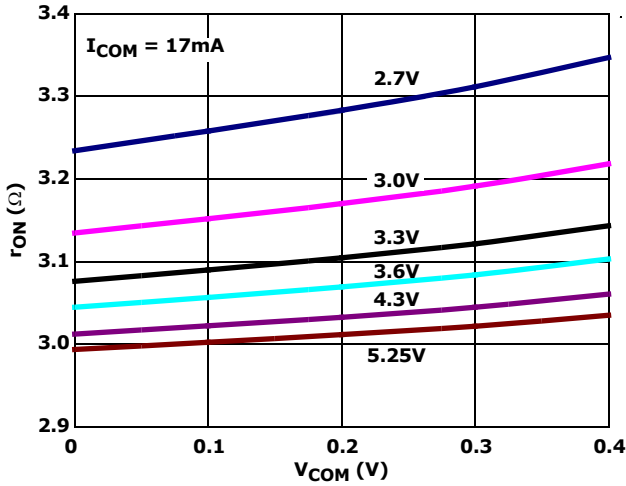
### USB 2.0 $V_{BUS}$ Short Requirements

The USB specification in section 7.1.1 states a USB device must be able to withstand a  $V_{BUS}$  short (4.4V to 5.25V) or a -1V short to the D+ or D- signal lines when the device is either powered off or powered on for at least 24 hours.

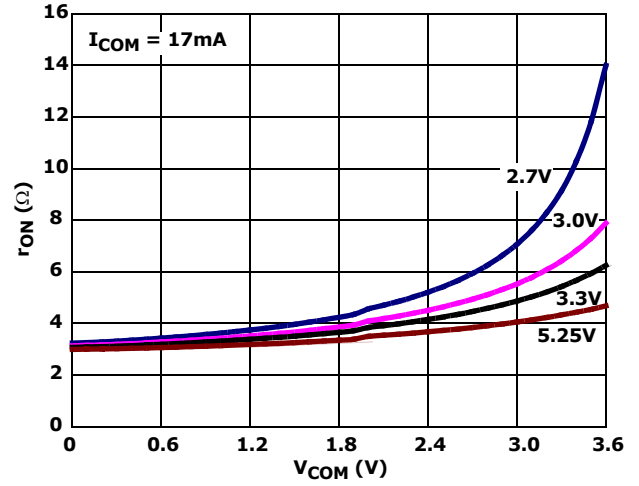
The ISL54228 part has special power-off protection and OVP detection circuitry to meet these short circuit requirements. This circuitry allows the ISL54228 to provide protection to the USB down-stream transceiver connected at its signal pins (D-, D+) to meet the USB specification short circuit requirements.

The power-off protection and OVP circuitry allows the COM pins (COM-, COM+) to be driven up to 5.25V or down to -5V while the  $V_{DD}$  supply voltage is in the range of 0V to 5.25V. In these overvoltage conditions, the part draws  $< 55\mu A$  of current into the COM pins and causes no stress/damage to the IC. In addition, all switches are OFF and the shorted  $V_{BUS}$  voltage will be isolated from getting through to the other side of the switch channels, thereby protecting the USB transceiver.

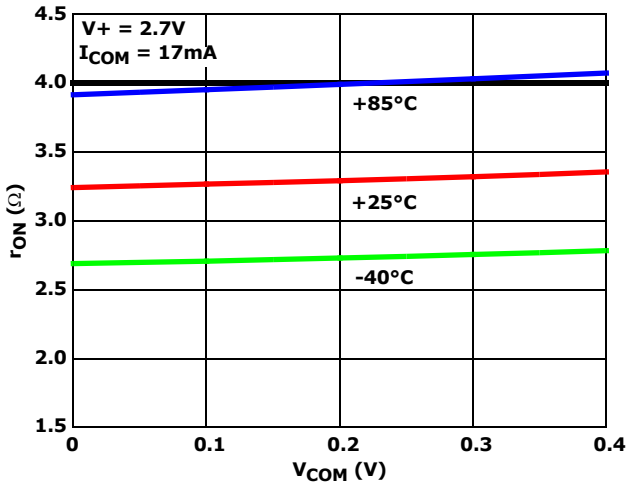
**Typical Performance Curves**  $T_A = +25^\circ\text{C}$ , Unless Otherwise Specified



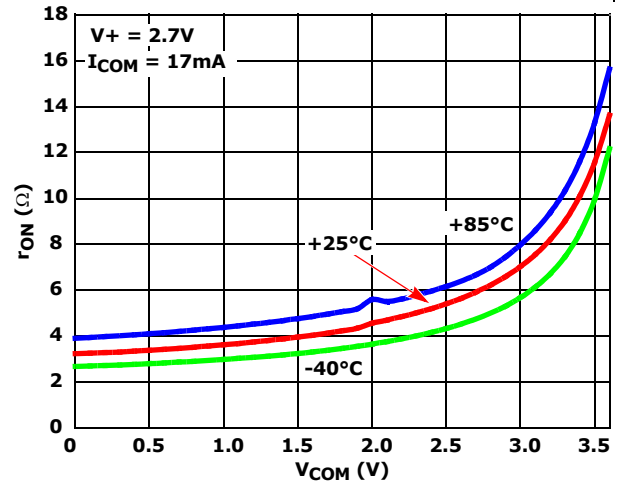
**FIGURE 8. ON-RESISTANCE vs SUPPLY VOLTAGE vs SWITCH VOLTAGE**



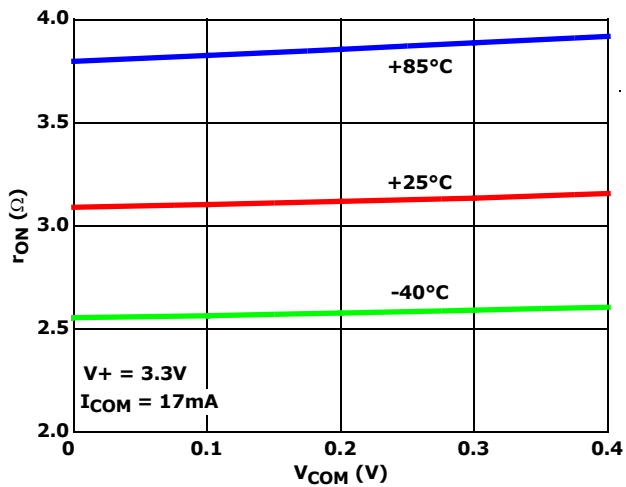
**FIGURE 9. ON-RESISTANCE vs SUPPLY VOLTAGE vs SWITCH VOLTAGE**



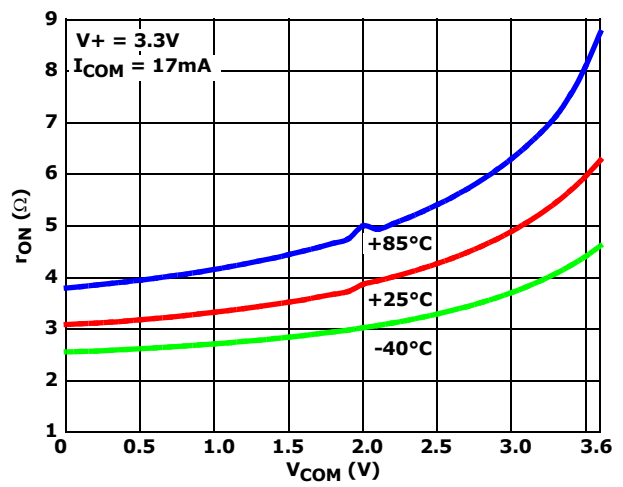
**FIGURE 10. ON-RESISTANCE vs SWITCH VOLTAGE**



**FIGURE 11. ON-RESISTANCE vs SWITCH VOLTAGE**

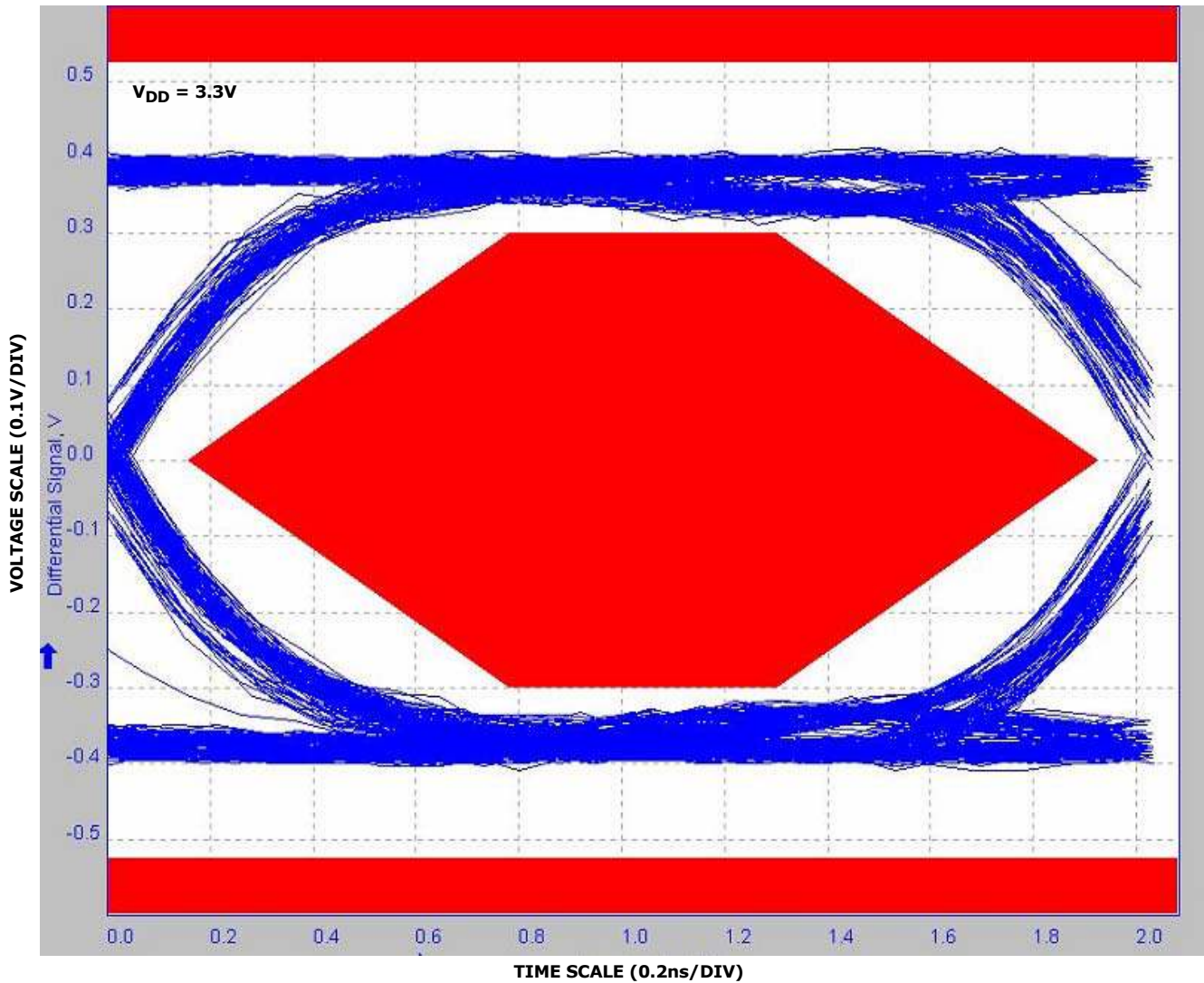


**FIGURE 12. ON-RESISTANCE vs SWITCH VOLTAGE**



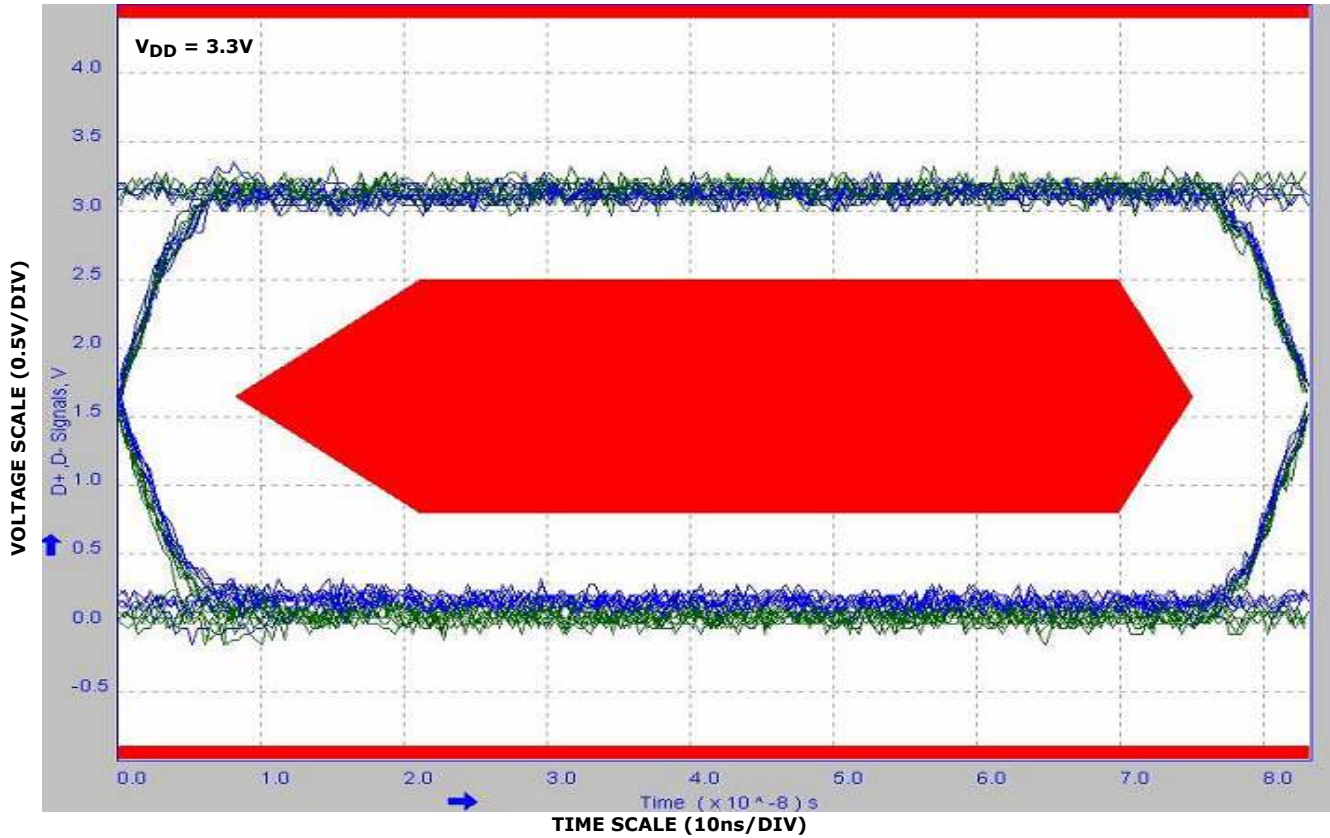
**FIGURE 13. ON-RESISTANCE vs SWITCH VOLTAGE**

**Typical Performance Curves**  $T_A = +25^\circ\text{C}$ , Unless Otherwise Specified (Continued)

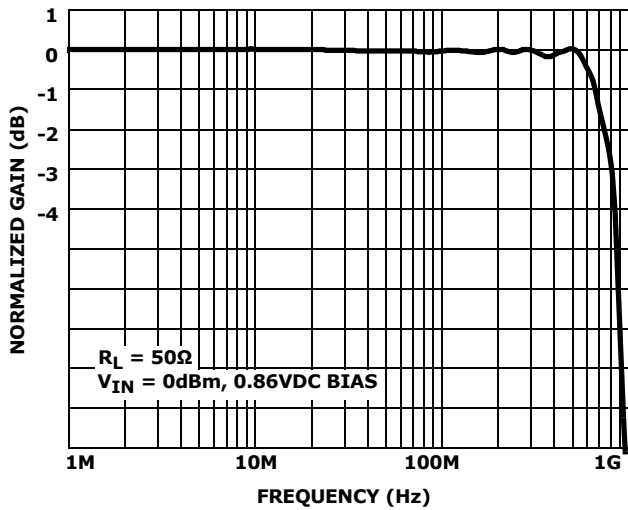


**FIGURE 14. EYE PATTERN: 480Mbps WITH USB SWITCHES IN THE SIGNAL PATH**

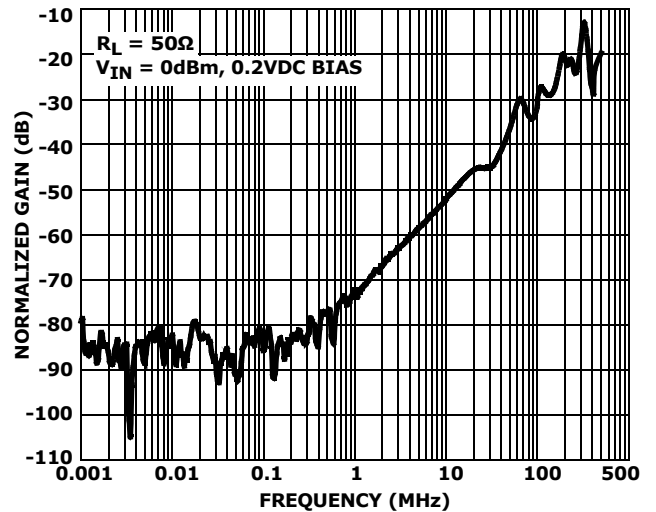
**Typical Performance Curves**  $T_A = +25^\circ\text{C}$ , Unless Otherwise Specified (Continued)



**FIGURE 15. EYE PATTERN: 12Mbps WITH USB SWITCHES IN THE SIGNAL PATH**



**FIGURE 16. FREQUENCY RESPONSE**



**FIGURE 17. OFF-ISOLATION**

## Typical Performance Curves $T_A = +25^\circ\text{C}$ , Unless Otherwise Specified (Continued)

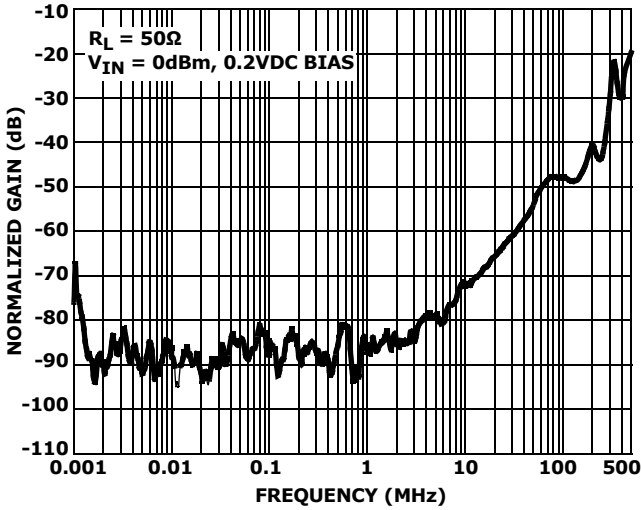


FIGURE 18. CROSSTALK

## Die Characteristics

### SUBSTRATE AND TDFN THERMAL PAD POTENTIAL (POWERED UP):

GND

### TRANSISTOR COUNT:

1297

### PROCESS:

Submicron CMOS

## Revision History

The revision history provided is for informational purposes only and is believed to be accurate, but not warranted. Please go to web to make sure you have the latest Rev.

DATE	REVISION	CHANGE
7/29/10	FN7628.0	Initial Release.

## Products

Intersil Corporation is a leader in the design and manufacture of high-performance analog semiconductors. The Company's products address some of the industry's fastest growing markets, such as, flat panel displays, cell phones, handheld products, and notebooks. Intersil's product families address power management and analog signal processing functions. Go to [www.intersil.com/products](http://www.intersil.com/products) for a complete list of Intersil product families.

\*For a complete listing of Applications, Related Documentation and Related Parts, please see the respective device information page on intersil.com: [ISL54228](http://www.intersil.com/ISL54228)

To report errors or suggestions for this datasheet, please go to [www.intersil.com/askourstaff](http://www.intersil.com/askourstaff)

FITs are available from our website at <http://rel.intersil.com/reports/search.php>

© Copyright Intersil Americas LLC 2010. All Rights Reserved.

All trademarks and registered trademarks are the property of their respective owners.

For additional products, see [www.intersil.com/en/products.html](http://www.intersil.com/en/products.html)

Intersil products are manufactured, assembled and tested utilizing ISO9001 quality systems as noted in the quality certifications found at [www.intersil.com/en/support/qualandreliability.html](http://www.intersil.com/en/support/qualandreliability.html)

*Intersil products are sold by description only. Intersil may modify the circuit design and/or specifications of products at any time without notice, provided that such modification does not, in Intersil's sole judgment, affect the form, fit or function of the product. Accordingly, the reader is cautioned to verify that datasheets are current before placing orders. Information furnished by Intersil is believed to be accurate and reliable. However, no responsibility is assumed by Intersil or its subsidiaries for its use; nor for any infringements of patents or other rights of third parties which may result from its use. No license is granted by implication or otherwise under any patent or patent rights of Intersil or its subsidiaries.*

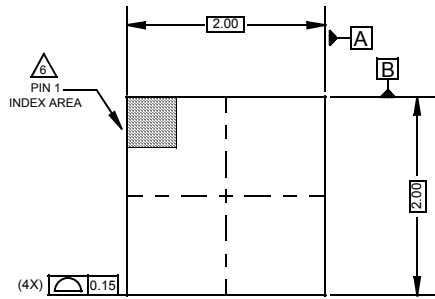
For information regarding Intersil Corporation and its products, see [www.intersil.com](http://www.intersil.com)

# Package Outline Drawing

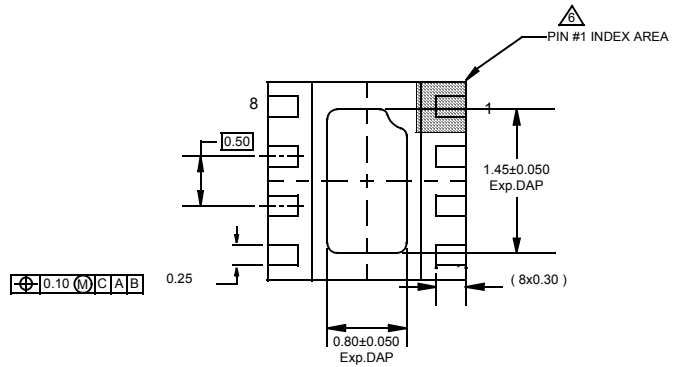
## L8.2x2C

8 LEAD THIN DUAL FLAT NO-LEAD PLASTIC PACKAGE (TDFN) WITH E-PAD

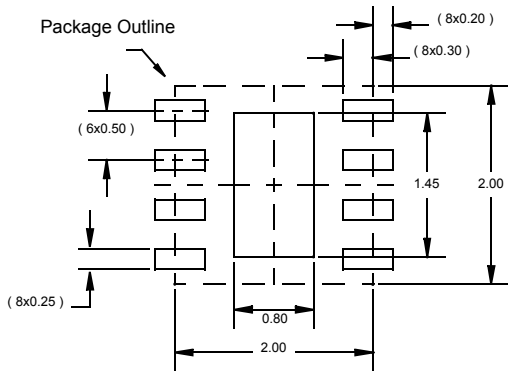
Rev 0, 07/08



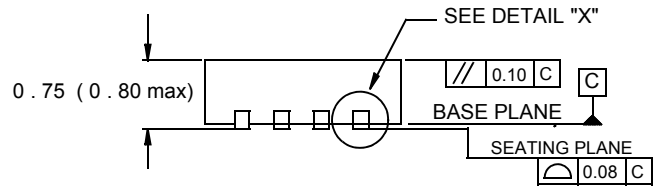
TOP VIEW



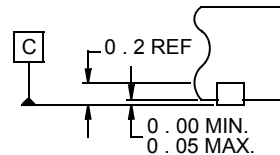
BOTTOM VIEW



TYPICAL RECOMMENDED LAND PATTERN



SIDE VIEW



DETAIL "X"

NOTES:

1. Dimensions are in millimeters.  
Dimensions in ( ) for Reference Only.
2. Dimensioning and tolerancing conform to AMSE Y14.5m-1994.
3. Unless otherwise specified, tolerance : Decimal ± 0.05
4. Dimension b applies to the metallized terminal and is measured between 0.15mm and 0.30mm from the terminal tip.
5. Tiebar shown (if present) is a non-functional feature.
6. The configuration of the pin #1 identifier is optional, but must be located within the zone indicated. The pin #1 identifier may be either a mold or mark feature.

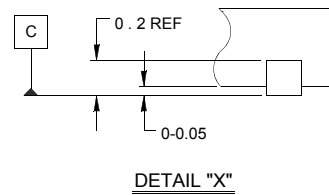
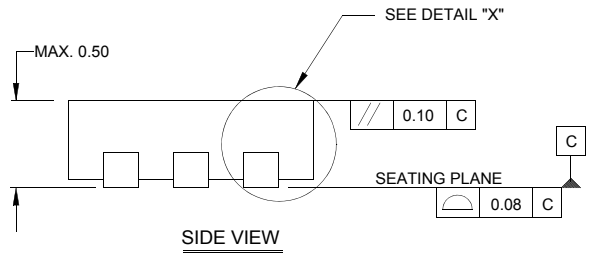
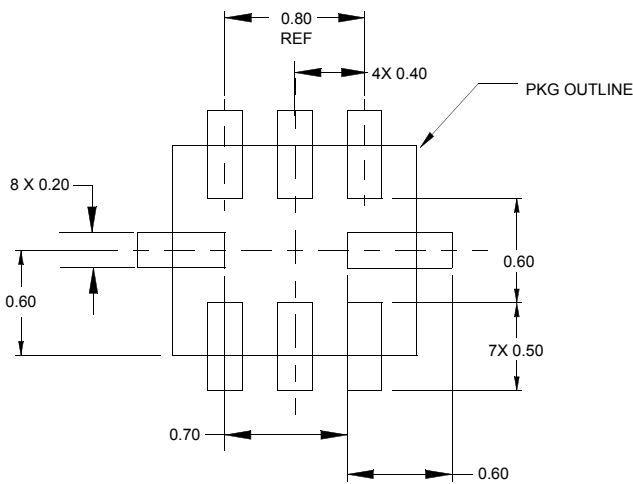
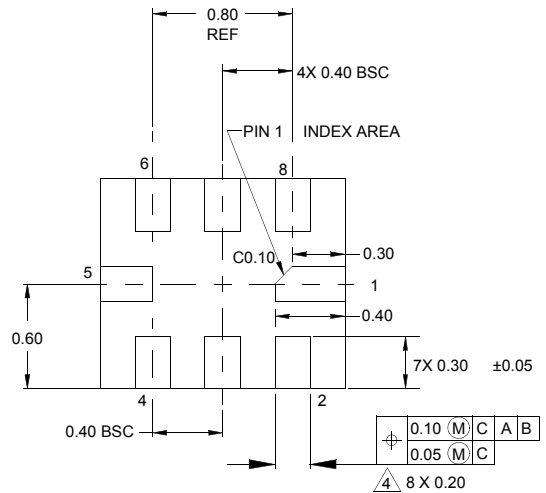
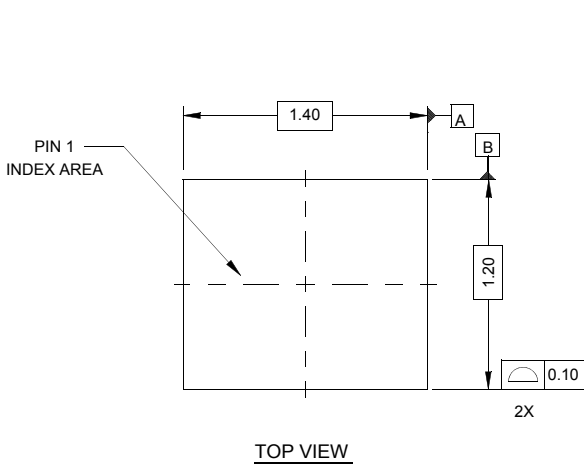


# Package Outline Drawing

## L8.1.4x1.2

### 8 LEAD QUAD FLAT NO-LEAD PLASTIC PACKAGE

Rev 0, 4/09



**NOTES:**

1. Dimensions are in millimeters.  
Dimensions in ( ) for Reference Only.
2. Dimensioning and tolerancing conform to AMSE Y14.5m-1994.
3. Unless otherwise specified, tolerance : Decimal  $\pm 0.05$
4. Dimension b applies to the metallized terminal and is measured between 0.15mm and 0.30mm from the terminal tip.
5. Tiebar shown (if present) is a non-functional feature.
6. The configuration of the pin #1 identifier is optional, but must be located within the zone indicated. The pin #1 identifier may be either a mold or mark feature.