

APPROVAL SHEET

Model No. : UB6018D-442S-YATRAC-00-0

Only No. : _____

Date : _____

APPROVER	CHECKER	DESIGN

Please kindly make approval of our samples, And return this form by fax or airmail, Thanks for your kind attention and co-operation.

Customer Name: _____

Customer Model No: _____

CUSTOMER APPROVAL

NAC HOLDINGS LIMITED.

Tel: 86-755-23341456 Fax: 86-755-23323921

Http://www.nacoustics.com sales@nacoustics.com

Type: Unidirectional Back Electret Condenser Microphone

Model Number: UB6018D-442S -YATRAC-00-0

1. Electrical Characteristics (Temperature =20±2°C Humidity=65±5%)

No	Parameter	Symbol	Condition	Limits			Unit
				Min.	Center	Max	
1.1	Sensitivity	S	0dB=1V/Pa, at 1kHz	-46	-44	-42	dB
1.2	Output impedance	Z out	f=1kHz		1.0	2.2	KΩ
1.3	Current Consumption	I _{DSS}				500	μA
1.4	Signal to Noise Ratio	S/N	at 1kHz S.P.L=1Pa (A-Weighted Curve)	60			dB
1.5	Decreasing Voltage	ΔS	V _{CC} =3.0V to2.0V			-3	dB
1.6	Operating Voltage			1.0		10	V
1.7	Maximum input S.P.L					110	dB
1.8	Directional Sensitivity		1kHz @ 180 degree	10			dB

2. Typical Frequency Response Curve

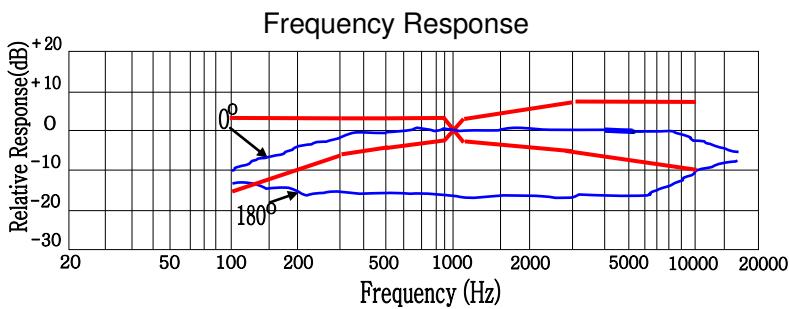

Microphone Response Tolerance Window

Frequency(Hz)	Lower Limit(dB)	Upper Limit(dB)
100	-15	+3
800	-4	+3
1000	0	0
1200	-4	+4
3000	-5	+8
5000	-6	+8
10000	-10	+8

3. Polar

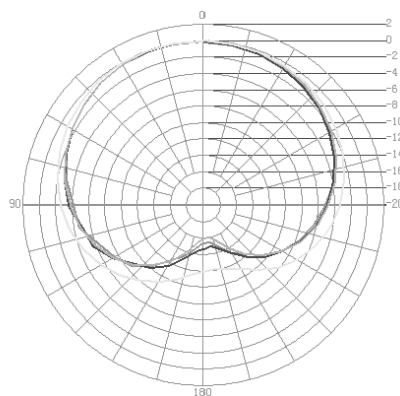

4. Measurement Circuit

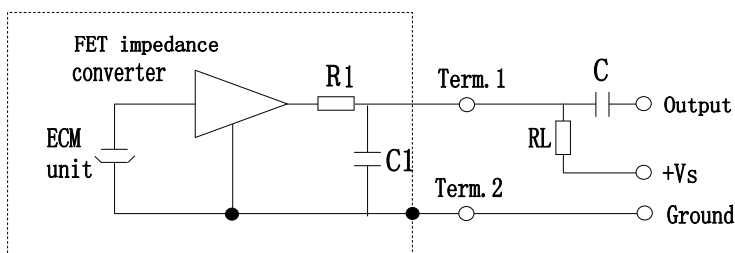

R _L =2.2KΩ
V _S =3.0V

5. Measurement Setup Drawing

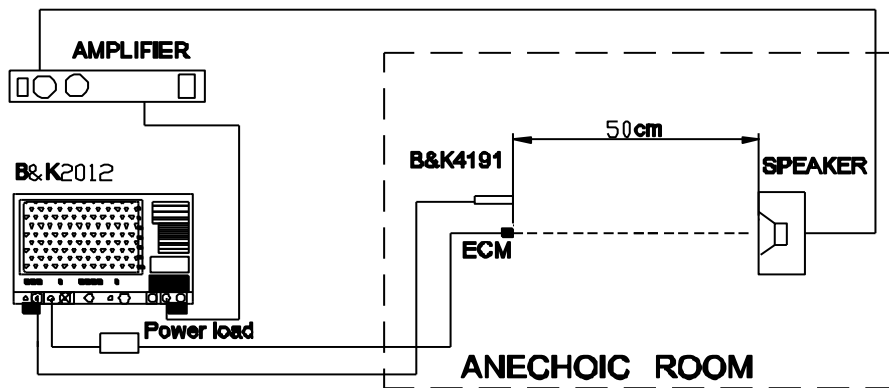

6. Appearance And Dimension

Unit: mm

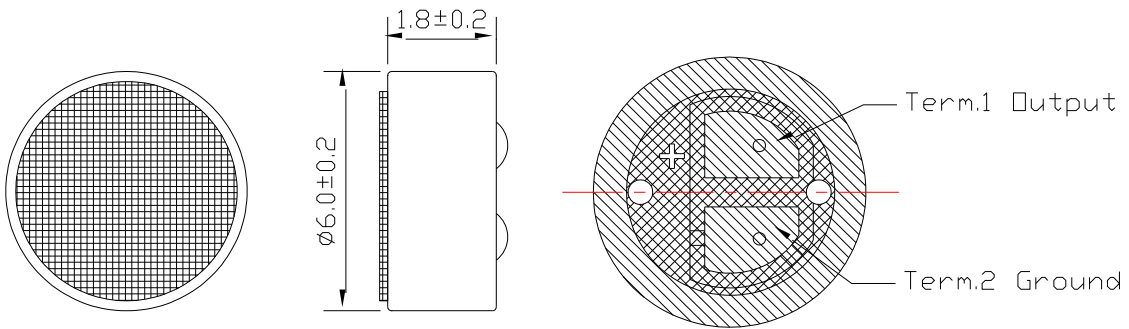

7. Material And Structure

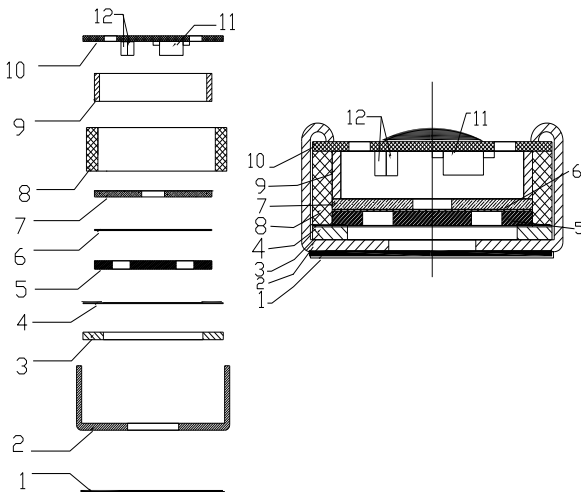

12	CAP/ RESISTANCE		3	
11	FET		1	
10	P.C.B		1	FR-4
9	Copper ring		1	
8	HOUSING CHAMBER		1	
7	one borepole blank			
6	Damping cotton		1	
5	ELECTRET			
4	SPACER		1	
3	POLARIZED DIAPHRAGM		1	
2	CASE		1	
1	FELT	Fabric cloth	1	
No.	Name	material	QTY	Remark

8. Accessory Drawing (Unit: mm)

TOP VIEW

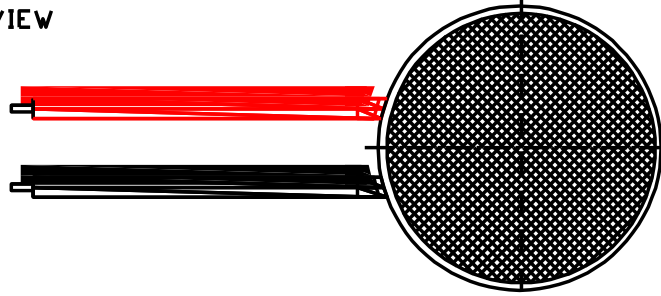

SIDE VIEW

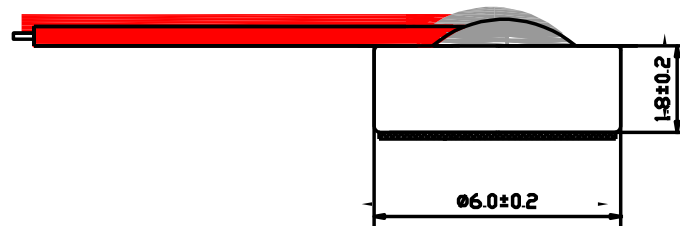

BOTTOM VIEW

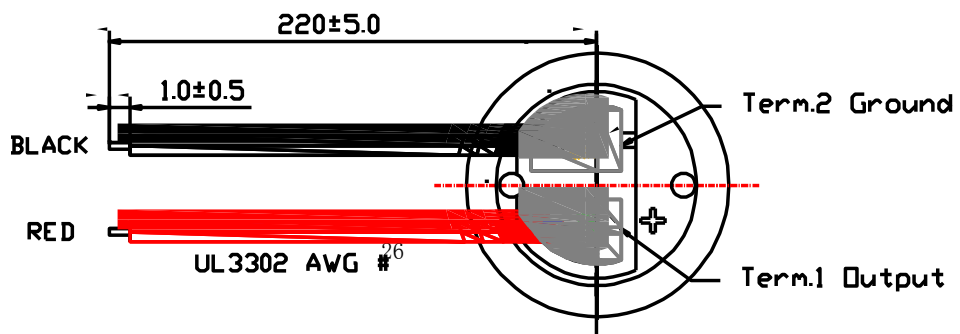

9. Temperature Conditions

Storage Temperature Range	Operation Temperature Range
-40°C ~ +85°C	-40°C ~ +85°C

Note: Store in electronic warehouse.

10. Terminal Mechanical Strength

Terminal should be no interference in operation after pulled the terminal with 1kg for 1 minute.

11. Reliability Test

After each of following test, the sensitivity of the microphone should be within $\pm 3\text{dB}$ of initial sensitivity after 3hours of conditioning at 20°C.

1. Vibration Test

Frequency : 10Hz~55Hz
 Amplitude : 1.52mm
 Change of Frequency : 1 octave/min
 2 hours in each of axes

2. High Temperature Test

+85°C for 240 hours.

3. Low Temperature Test

-40°C for 240 hours.

4. Humidity Test

90%~95%RH,+60°C for 240 hours.

5. Thermal shocking test

-40°C, 30 minutes \leftrightarrow +80°C, 30 minutes, repeated 32 cycles \rightarrow room temperature, 3 hours.

6. Temperature Cycles

-40°C \longleftrightarrow +20°C \longleftrightarrow +85°C \longleftrightarrow +20°C \longleftrightarrow -40°C
 (2h) (0.5h) (2h) (0.1h) (2h) (0.5h) (2h) (0.5h) (2h) for 5 cycles.

7. Packing Drop Test

Height: 1.5m
 Procedure: 5 times from each of axes

8. Electrostatic discharge

Tested to IEC61000-4-2 level 3:

a) Contact discharge

The microphone shall operate normally after 10 discharges to is 6KV DC and the discharge network is 150pF and 330Ω.

b) Air discharge

The microphone shall operate normally after 10 discharges to is 8KV DC and the discharge network is 150pF and 330Ω

12. Soldering Condition

1. We suggest using anti-static welding machine which can control soldering temperature automatically.
2. Soldering temperature should be controlled under 320°C and soldering time for each terminal should be 1~2 sec..
3. Microphone should be fixed on the metal block (heat sink), which has high radiation effects, and heat sink shall contact with MIC tightly.
4. Microphone may easily be destroyed by the static electricity and the countermeasure for eliminating the static electricity shall be executed (worktable and human body shall be ground connection).

5. Heat Sink

Shape of heat sink

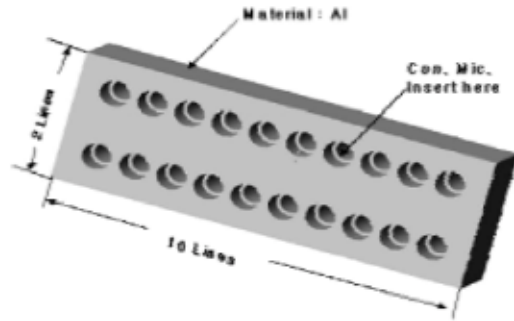

Shape of hole at fixed part

