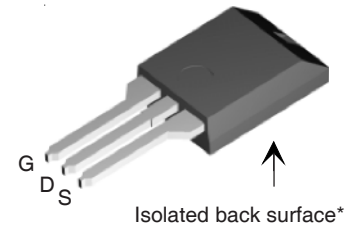

Trench Power MOSFET **IXUC160N075** ISOPLUS220™

Electrically Isolated Back Surface
 $V_{DSS} = 75 \text{ V}$
 $I_{D25} = 160 \text{ A}$
 $R_{DS(on)} = 6.5 \text{ m}\Omega$

ISOPLUS 220™

G = Gate, D = Drain,
S = Source

Symbol	Test Conditions	Maximum Ratings	
V_{DSS}	$T_J = 25^\circ\text{C to } 150^\circ\text{C}$	75	V
V_{GS}	Continuous	± 20	V
I_{D25}	$T_C = 25^\circ\text{C}$; Note 1	160	A
I_{D90}	$T_C = 90^\circ\text{C}$; Note 1	130	A
I_{S25}	$T_C = 25^\circ\text{C}$; Note 1, 2	160	A
I_{S90}	$T_C = 90^\circ\text{C}$; Note 1, 2	120	A
$I_{D(RMS)}$	Package lead current limit	50	A
E_{AS}	$T_C = 25^\circ\text{C}$	tbd	mJ
P_D	$T_C = 25^\circ\text{C}$	300	W
T_J		-55 ... +175	$^\circ\text{C}$
T_{JM}		175	$^\circ\text{C}$
T_{stg}		-55 ... +150	$^\circ\text{C}$
T_L	1.6 mm (0.062 in.) from case for 10 s	300	$^\circ\text{C}$
V_{ISOL}	RMS leads-to-tab, 50/60 Hz, $t = 1$ minute	2500	V~
F_c	Mounting force	11 ... 65 / 2.4 ... 11	N/lb
Weight		2	g

Features

- Silicon chip on Direct-Copper-Bond substrate
 - High power dissipation
 - Isolated mounting surface
 - 2500V electrical isolation
- Trench MOSFET
 - very low $R_{DS(on)}$
 - fast switching
 - usable intrinsic reverse diode
- Low drain to tab capacitance (<15pF)
- Unclamped Inductive Switching (UIS) rated

Applications

- Automotive 42V and 12V systems
 - electronic switches to replace relays and fuses
 - choppers to replace series dropping resistors used for motors, heaters, etc.
 - inverters for AC drives, e.g. starter generator
 - DC-DC converters, e.g. 12V to 42V, etc.
- Power supplies
 - DC - DC converters
 - Solar inverters
- Battery powered systems
 - choppers or inverters for motor control in hand tools
 - battery chargers

Advantages

- Easy assembly: no screws or isolation foils required
- Space savings
- High power density

Symbol	Test Conditions	Characteristic Values ($T_J = 25^\circ\text{C}$, unless otherwise specified)		
		min.	typ.	max.
$R_{DS(on)}$	$V_{GS} = 10 \text{ V}$, $I_D = 100 \text{ A}$, Note 3 $V_{GS} = 10 \text{ V}$, $I_D = I_{D90}$, Note 3		10.2	6.5 m Ω m Ω
$V_{GS(th)}$	$V_{DS} = V_{GS}$, $I_D = 2 \text{ mA}$	2		4 V
I_{DSS}	$V_{DS} = V_{DSS}$ $V_{GS} = 0 \text{ V}$		1	20 μA mA
I_{GSS}	$V_{GS} = \pm 20 \text{ V}_{DC}$, $V_{DS} = 0$			± 200 nA

Symbol	Test Conditions	Characteristic Values ($T_J = 25^\circ\text{C}$, unless otherwise specified)		
		min.	typ.	max.
$Q_{g(on)}$	$V_{GS} = 10\text{ V}, V_{DS} = 0.5 V_{DSS}, I_D = 100\text{ A}$		250	nC
Q_{gs}			tbd	nC
Q_{gd}			tbd	nC
$t_{d(on)}$	$V_{GS} = 10\text{ V}, V_{DS} = 40\text{ V},$ $I_D = 90\text{ A}, R_G = 4.7\ \Omega$		50	ns
t_r			40	ns
$t_{d(off)}$			190	ns
t_f			55	ns
R_{thJC}			0.5	K/W
R_{thCH}		0.30		K/W

Source-Drain Diode

Symbol	Test Conditions	Characteristic Values ($T_J = 25^\circ\text{C}$, unless otherwise specified)		
		min.	typ.	max.
V_{SD}	$I_F = 80\text{ A}, V_{GS} = 0\text{ V}$ Note 3		1.1	1.5 V
t_{rr}	$I_F = 90\text{ A}, di/dt = -250\text{ A}/\mu\text{s}, V_{DS} = 0.5 V_{DSS}$		120	ns

- Note: 1. MOSFET chip capability
 2. Intrinsic diode capability
 3. Pulse test, $t \leq 300\ \mu\text{s}$, duty cycle $d \leq 2\%$

ISOPLUS220 Outline

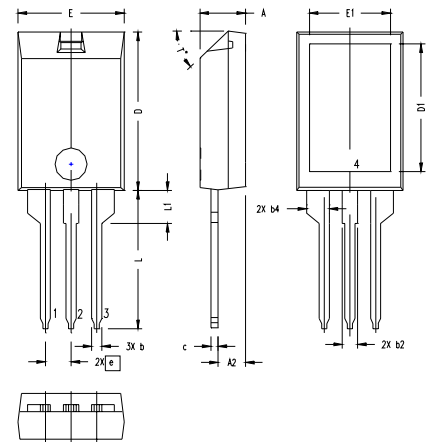

SYM	INCHES		MILLIMETERS	
	MIN	MAX	MIN	MAX
A	.157	.197	4.00	5.00
A2	.098	.118	2.50	3.00
b	.035	.051	0.90	1.30
b2	.049	.065	1.25	1.65
b4	.093	.100	2.35	2.55
c	.028	.039	0.70	1.00
D	.591	.630	15.00	16.00
D1	.472	.512	12.00	13.00
E	.394	.433	10.00	11.00
E1	.295	.335	7.50	8.50
e	.100 BASIC		2.55 BASIC	
L	.512	.571	13.00	14.50
L1	.118	.138	3.00	3.50
T*			42.5*	47.5*

- NOTE:
 1. Bottom heatsink (Pin 4) is electrically isolated from Pin 1, 2, or 3.
 2. This drawing will meet dimensional requirement of JEDEC SS Product Outline TO-273 except D and D1 dimension.

IXYS reserves the right to change limits, test conditions, and dimensions.

IXYS MOSFETs and IGBTs are covered by one or more of the following U.S. patents:	4,835,592	4,881,106	5,017,508	5,049,961	5,187,117	5,486,715	6,306,728B1	6,259,123B1	6,306,728B1
	4,850,072	4,931,844	5,034,796	5,063,307	5,237,481	5,381,025	6,404,065B1	6,162,665	6,534,343