

**SPECIFICATION
FOR
LCD Module**

Customer P/N:

Santek P/N: ST0700IF-RSLW-F

DOC. Revision: RS02

Customer Approval:

--

	SIGNATURE	DATE
PREPARED BY	Vivian Huang	2016-07-13
CHECKED BY	YF Zhou	2015-07-13
APPROVED BY	Natty Lee	2016-Jul-13

Document Revision History

Version	Revise Date	Description	Changed by
RS01	2016.07.05	Initial release	Vivian Huang
RS02	2016.07.13	Modify drawings	YF Zhou

Table of Contents

1. APPLICATION.....	4
2. GENERAL SPECIFICATIONS	4
3. ABSOLUTE MAXIMUM RATINGS	4
4. ELECTRICAL CHARACTERISTICS	4
5. INPUT SIGNAL CHARACTERISTICS.....	5
6. OPTICAL CHARACTERISTIC	9
7. PIN CONNECTIONS	12
8. BLOCK DIAGRAM	14
9. QUALITY ASSURANCE	15
10. OUTLINE DRAWING	16
11. PACKAGE INFORMATION.....	17

Santek - CONFIDENTIAL

1. APPLICATION

DVD player, Car TV, UMPC, POS

2. GENERAL SPECIFICATIONS

Parameter	Specifications	Unit
Screen Size	7 (diagonal)	inch
Display Format	800(H) x (R,G,B) x 480(V)	dot
Active Area	152.4(H) x 91.44(V)	mm
Dot Pitch	0.0635 (H) x 0.1905 (V)	mm
Pixel Configuration	Stripe	
Outline Dimension	165(W) x 104.44(H) x 9.7 (D) Max	mm
Surface treatment	Anti-glare	
Back-light	LED	
Display mode	Normally white	
Weight	132	g
View Angle direction	6 o'clock	

3. ABSOLUTE MAXIMUM RATINGS

Parameter	Symbol	MIN.	MAX.	Unit	Remark
Power supply voltage	V _{CC}	-0.3	6.0	V	Ta=25°C
Logic input voltage	V _I	-0.3	V _{CC} +0.3	V	
Operating temperature	T _{OP}	-20	+70	°C	Module surface*
Storage temperature	T _{ST}	-30	+80	°C	-
Humidity	Operation	20%~90% relative humidity			Ta<=38°C
	Non Operation	5%~90% relative humidity			Ta<=38°C

4. ELECTRICAL CHARACTERISTICS

f_H=30KHz, f_V=60Hz, f_{CLK}=33.3MHz, Ta=25°C

Parameter	Symbol	MIN.	Typ.	MAX.	Unit	Remark
Power Supply voltage for LCD	V _{CC}	+3.0	+3.3	+3.6	V	
Power Supply Current for LCD	I _{CC}		150	200	mA	V _{CC} =3.3V
Power Supply voltage for LED	V _{DD}	3	3.3	5.5	V	
Power Supply Current for LED	I _{DD}		700	850	mA	V _{DD} =3.3V
Power Supply Current for LED	I _{DD}		500	650	mA	V _{DD} =5.0V
Ripple voltage	V _{RF}	-	-	100	mV _{P-P}	
ADJ frequency		19K	20K	21K	Hz	
ADJ input voltage	V _{IH}	3.0	-	3.3	V	
	V _{IL}	0	-	0.3	V	
Differential Input High Threshold	V _{TH}	-	-	100	[mV]	V _{CM} =1.2V Note 1
Differential input Low Threshold	V _{TL}	-100	-	-	[mV]	
LED dice life time			50000		Hr	Note 2

Note 1: LVDS Signal Waveform.

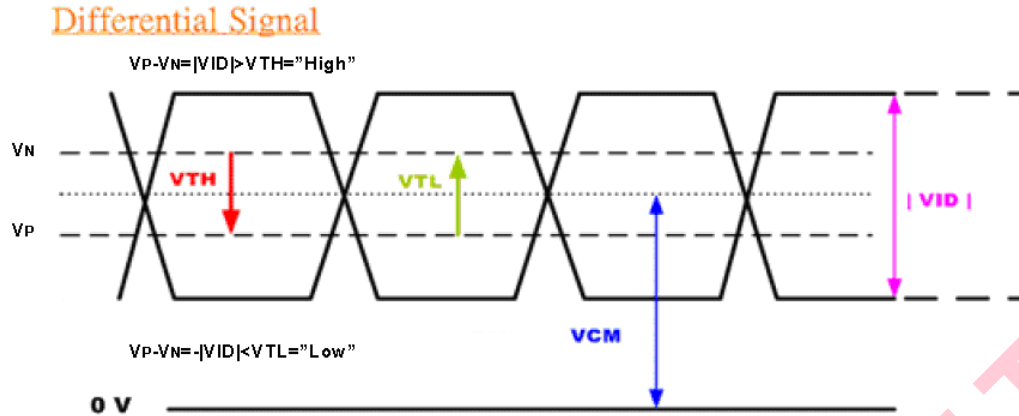

Note 2: The "LED dice life time" is defined as the brightness decrease to 50% original brightness that the ambient temperature is 18°C~28°C and LED dice current=20mA.

5. INPUT SIGNAL CHARACTERISTICS

5.1 AC Characteristics

5.1.1 AC Electrical Characteristics

Parameter	Symbol	MIN.	TYP.	MAX.	Unit
Data setup time	T_{dsu}	6	-	-	ns
Data hold time	T_{dhd}	6	-	-	ns
DE setup time	T_{esu}	6	-	-	ns

5.1.2 Resolution: 800x480

Parameter	Symbol	MIN.	TYP.	MAX.	Unit
DCLK frequency	F_{CPH}	25	33.26	40	MHz
DCLK period	T_{CPH}	-	30.06	-	ns
DCLK pulse duty	T_{CWH}	40	50	60	%
DE period	$T_{DEH} + T_{DEL}$	1000	1056	1200	T_{CPH}
DE pulse width	T_{DEH}	-	800	-	T_{CPH}
DE frame blanking	T_{DEB}	10	45	110	$T_{DEH} + T_{DEL}$
DE frame width	T_{DE}	-	480	-	$T_{DEH} + T_{DEL}$

5.2 Timing Controller Timing Chart

5.2.1 Clock and Data input waveforms

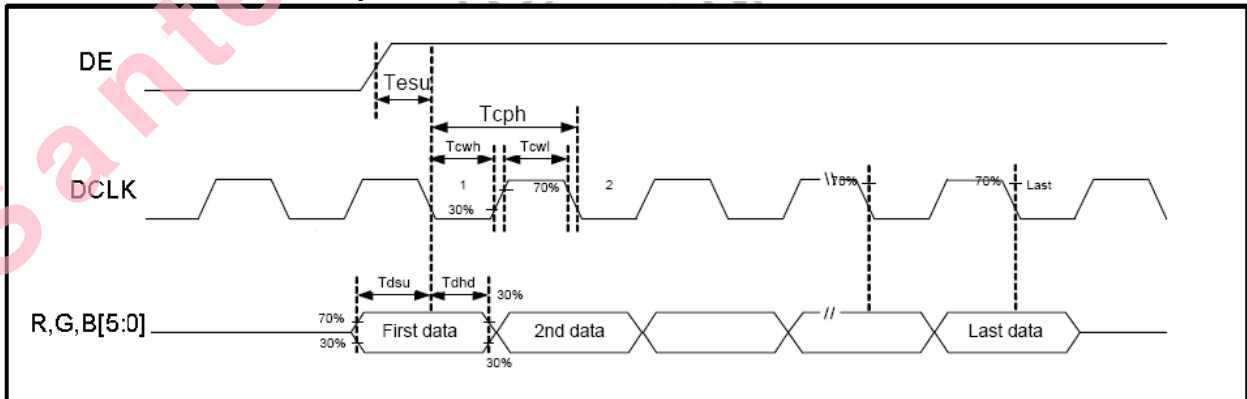
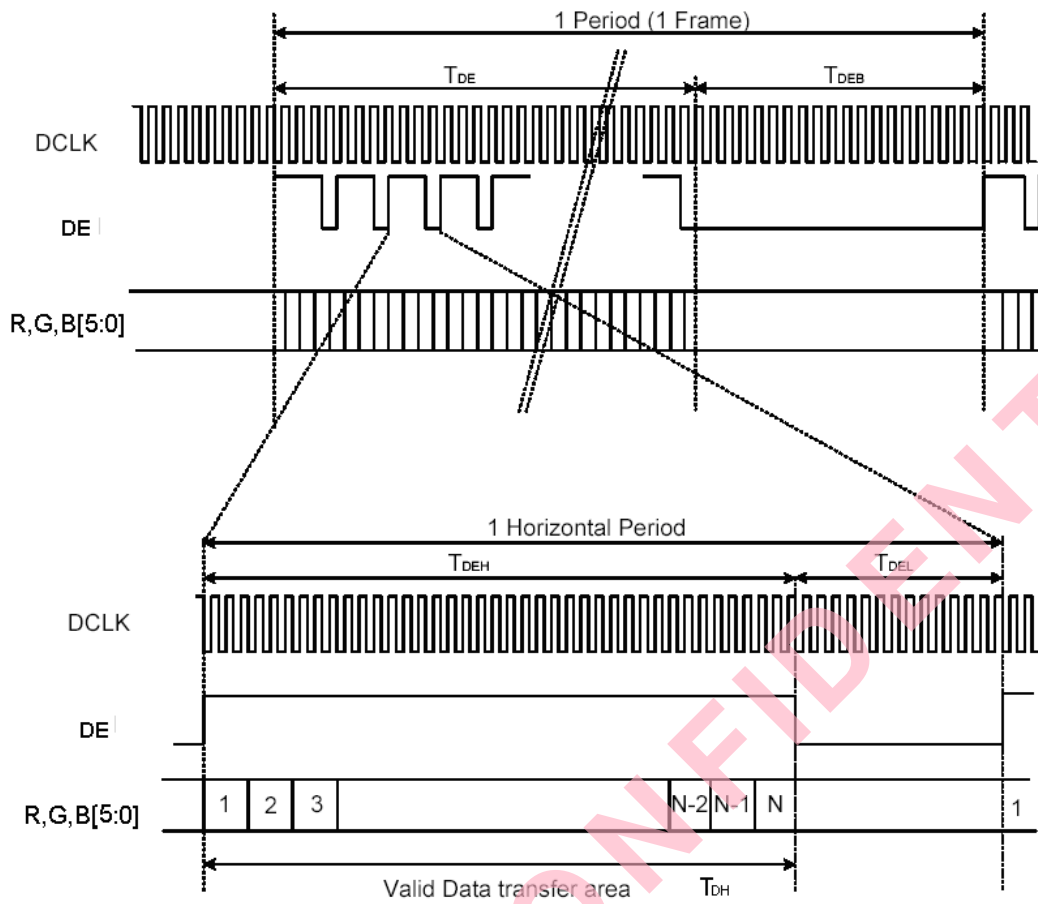
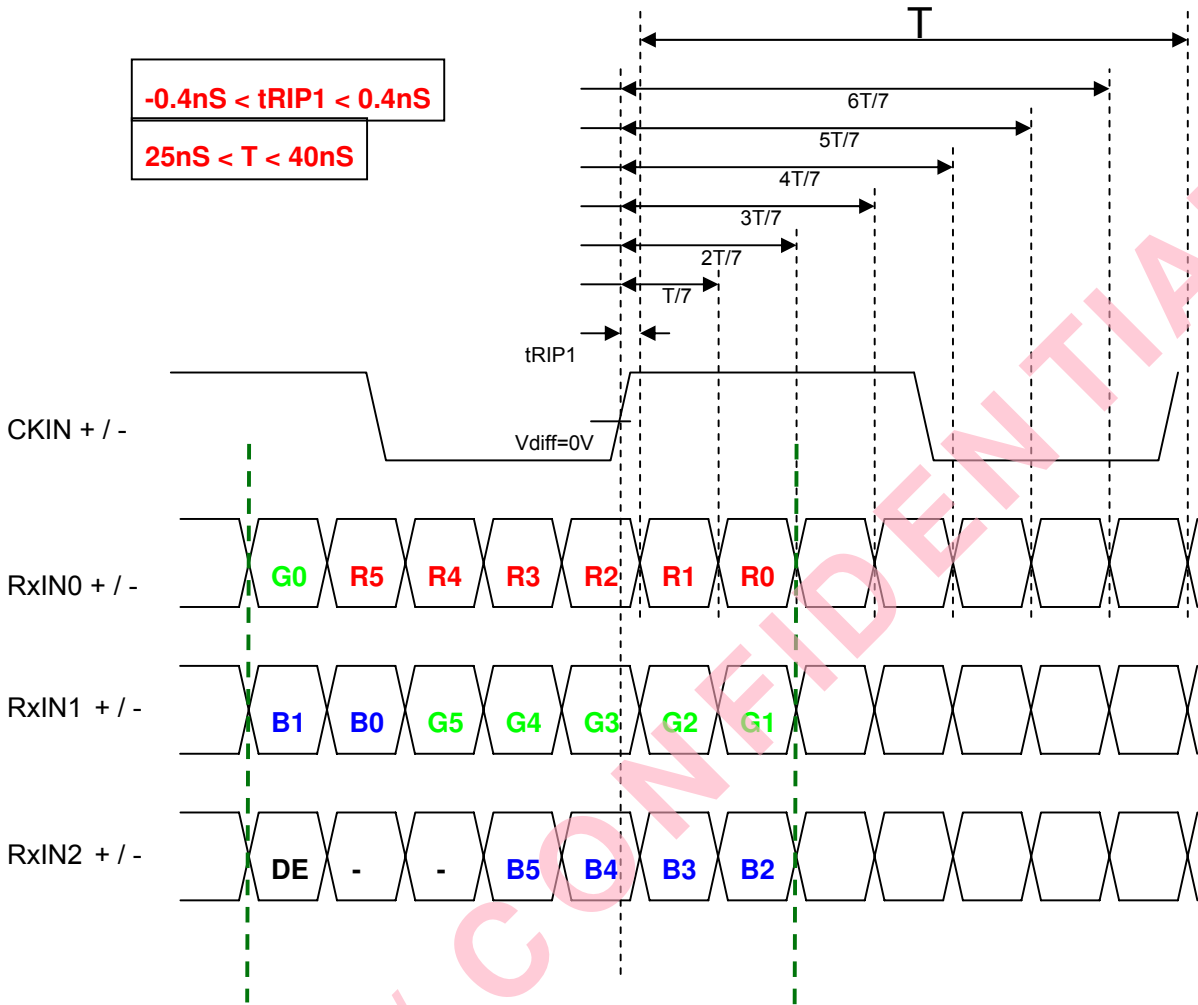

Figure 1 Clock and Data input waveforms.



5.2.2 LVDS Timing Chart



5.3 Color Data Input Assignment

		Data Signal																	
		Red						Green						Blue					
Color		R5	R4	R3	R2	R1	R0	G5	G4	G3	G2	G1	G0	B5	B4	B3	B2	B1	B0
Basic Colors	Black	0	0	0	0	0	0	0	0	0	0	0	0	0	0	0	0	0	0
	Red	1	1	1	1	1	1	0	0	0	0	0	0	0	0	0	0	0	0
	Green	0	0	0	0	0	0	1	1	1	1	1	1	0	0	0	0	0	0
	Blue	0	0	0	0	0	0	0	0	0	0	0	0	1	1	1	1	1	1
	Cyan	0	0	0	0	0	0	1	1	1	1	1	1	1	1	1	1	1	1
	Magenta	1	1	1	1	1	1	0	0	0	0	0	0	1	1	1	1	1	1
	Yellow	1	1	1	1	1	1	1	1	1	1	1	1	0	0	0	0	0	0
	White	1	1	1	1	1	1	1	1	1	1	1	1	1	1	1	1	1	1
Gray Scale of Red	Red(0) / Dark	0	0	0	0	0	0	0	0	0	0	0	0	0	0	0	0	0	0
	Red(1)	0	0	0	0	0	1	0	0	0	0	0	0	0	0	0	0	0	0
	Red(2)	0	0	0	0	1	0	0	0	0	0	0	0	0	0	0	0	0	0
	:	:	:	:	:	:	:	:	:	:	:	:	:	:	:	:	:	:	:
	:	:	:	:	:	:	:	:	:	:	:	:	:	:	:	:	:	:	:
	Red(61)	1	1	1	1	0	1	0	0	0	0	0	0	0	0	0	0	0	0
	Red(62)	1	1	1	1	1	0	0	0	0	0	0	0	0	0	0	0	0	0
	Red(63)	1	1	1	1	1	1	0	0	0	0	0	0	0	0	0	0	0	0
Gray Scale of Green	Green(0)/ Dark	0	0	0	0	0	0	0	0	0	0	0	0	0	0	0	0	0	0
	Green(1)	0	0	0	0	0	0	0	0	0	0	0	1	0	0	0	0	0	0
	Green(2)	0	0	0	0	0	0	0	0	0	0	1	0	0	0	0	0	0	0
	:	:	:	:	:	:	:	:	:	:	:	:	:	:	:	:	:	:	:
	:	:	:	:	:	:	:	:	:	:	:	:	:	:	:	:	:	:	:
	Green(61)	0	0	0	0	0	0	1	1	1	1	0	1	0	0	0	0	0	0
	Green(62)	0	0	0	0	0	0	1	1	1	1	1	0	0	0	0	0	0	0
	Green(63)	0	0	0	0	0	0	1	1	1	1	1	1	0	0	0	0	0	0
Gray Scale of Blue	Blue(0)/ Dark	0	0	0	0	0	0	0	0	0	0	0	0	0	0	0	0	0	0
	Blue (1)	0	0	0	0	0	0	0	0	0	0	0	0	0	0	0	0	0	1
	Blue (2)	0	0	0	0	0	0	0	0	0	0	0	0	0	0	0	0	0	1
	:	:	:	:	:	:	:	:	:	:	:	:	:	:	:	:	:	:	:
	:	:	:	:	:	:	:	:	:	:	:	:	:	:	:	:	:	:	:
	Blue (61)	0	0	0	0	0	0	0	0	0	0	0	0	1	1	1	1	1	0
	Blue (62)	0	0	0	0	0	0	0	0	0	0	0	0	1	1	1	1	1	0
	Blue (63)	0	0	0	0	0	0	0	0	0	0	0	0	1	1	1	1	1	1

Correspondence between Data and Display Position

	S0001	S0002	S0003	S0004	S0005	S0006	S0007	S0008	-----	S2399	S2400
C001	R001	G001	B001	R002	G002	B002	R003	G003		G800	B800
C480	R001	G001	B001	R002	G002	B002	R003	G003		G800	B800

6. OPTICAL CHARACTERISTIC

Parameter		Symbol	Condition	MIN.	TYP.	MAX.	Unit	Remarks
Viewing Angle	Horizontal	θ_{x+}	Center CR \geq 10	65	70	--	deg	Note 1,4
		θ_{x-}		65	70	--		
	Vertical	θ_{y+}		55	60	--		
		θ_{y-}		55	60	--		
Contrast Ratio		CR	at optimized viewing angle	250	400	--		Note 1,3
Response time	Rise	Tr	Center $\theta_x=\theta_y=0^\circ$	-	5	10	ms	Note 1,6
	Fall	Tf		-	11	16	ms	
Uniformity		B-uni	$\theta_x=\theta_y=0^\circ$	70	80	--	%	Note 1,5
Brightness		L	$\theta_x=\theta_y=0^\circ$	300	400	--	cd/m ²	Note 1,2
Chromaticity	x_W	Center $\theta_x=\theta_y=0^\circ$	0.26	0.31	0.36			Note 1,7
	y_W		0.28	0.33	0.38			
	x_R		0.52	0.57	0.62			
	y_R		0.31	0.36	0.41			
	x_G		0.30	0.35	0.40			
	y_G		0.53	0.58	0.63			
	x_B		0.10	0.15	0.20			
	y_B		0.09	0.14	0.19			
Image sticking		tis	2 hours			2	Sec	Note 8

The following optical specifications shall be measured in a darkroom or equivalent state (ambient luminance \leq 1 lux, and at room temperature). The operation temperature is 25°C \pm 2°C. The measurement method is shown in Note1.

Note1: The method of optical measurement:

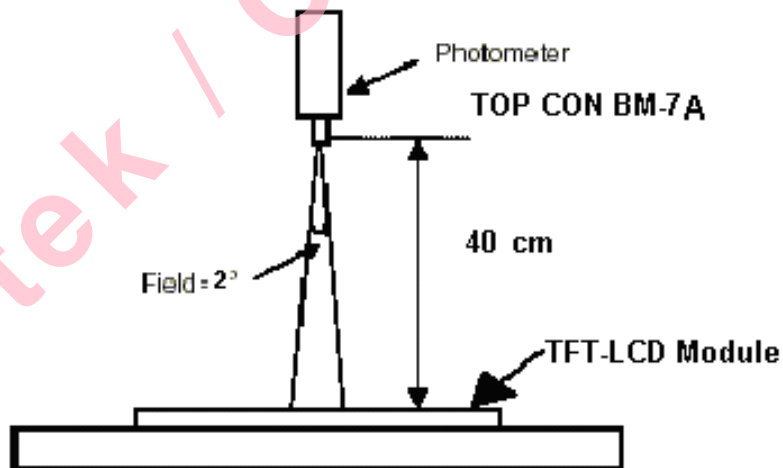

Note2: Measured at the center area of the panel and at the viewing angle of the $\theta_x = \theta_y = 0^\circ$

Note3: Definition of Contrast Ratio (CR):

$$CR = \frac{\text{Luminance with all pixels in white state}}{\text{Luminance with all pixels in Black state}}$$

Note4: Definition of Viewing Angle

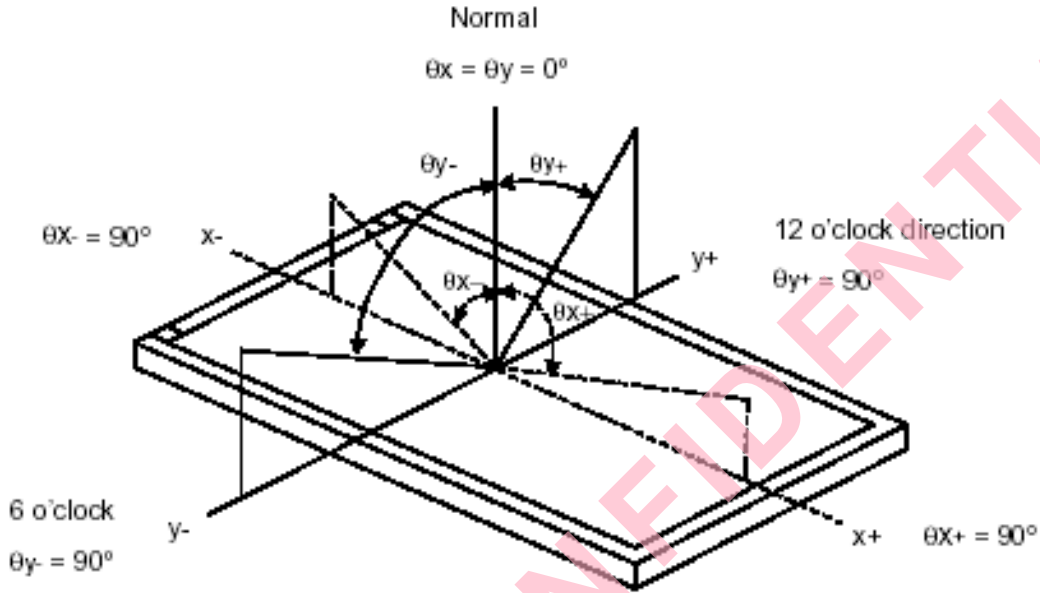

Note 5: Definition of Brightness Uniformity (B-uni):

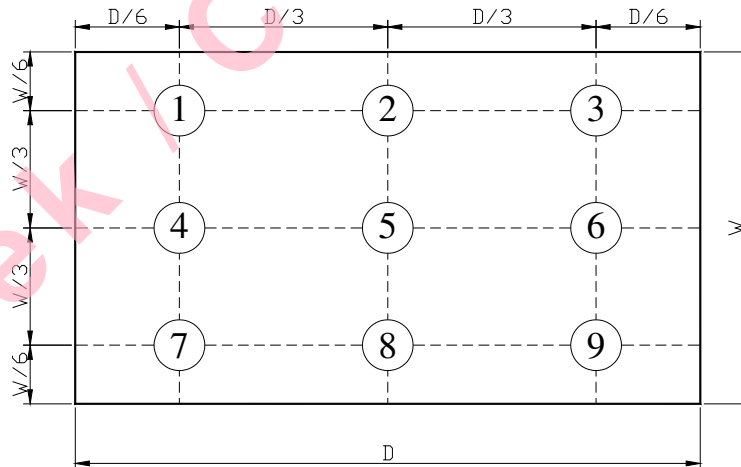

$$B\text{-uni} = \frac{\text{Minimum luminance of 9 points}}{\text{Maximum luminance of 9 points}} \quad (\text{Note 5}).$$

Note6: Definition of Response Time:

The Response Time is set initially by defining the "Rising Time (T_r)" and the "Falling Time (T_f)" respectively. T_r and T_f are defined as following figure.

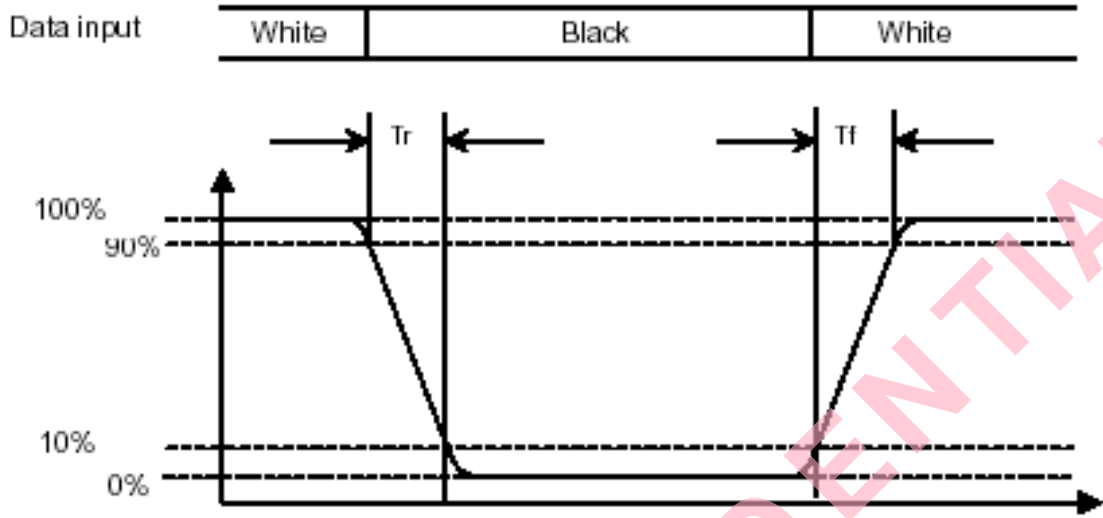

Note 7: Definition of Chromaticity:

The color coordinates (x_w, y_w), (x_r, y_r), (x_g, y_g), and (x_b, y_b) are obtained with all pixels in the viewing field at white, red, green, and blue states, respectively.

Note 8: Definition of Image sticking (tis):

Continuously display the test pattern shown in the figure below for 2 hours. Then display a completely white screen. The previous image shall not persist more than 2 sec at 25 °C

Image sticking pattern

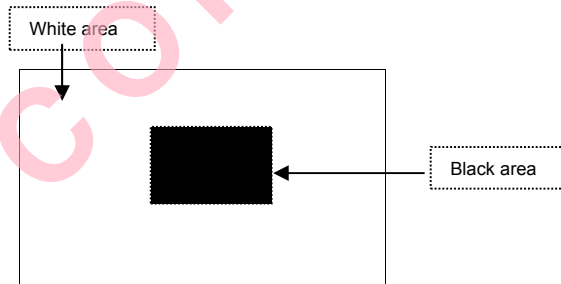

7. PIN CONNECTIONS

7.1TFT PIN Connections

Pin No	Symbol	Function	Remark
1	VCC	power supply for Digital Circuit	
2	VCC	power supply for Digital Circuit	
3	GND	Ground	
4	GND	Ground	
5	RxIN0-	Differential Data Input ,CH0(Negative)	
6	RxIN0+	Differential Data Input ,CH0(Positive)	
7	GND	Ground	
8	RxIN1-	Differential Data Input ,CH1(Negative)	
9	RxIN1+	Differential Data Input ,CH1(Positive)	
10	GND	Ground	
11	RxIN2-	Differential Data Input ,CH2(Negative)	
12	RxIN2+	Differential Data Input ,CH2(Positive)	
13	GND	Ground	
14	CKIN-	Differential Clock Input (Negative)	
15	CKIN+	Differential Clock Input (Positive)	
16	GND	Ground	
17	VDD	Power Supply for LED Driver Circuit	
18	VDD	Power Supply for LED Driver Circuit	
19	GND	Ground	
20	ADJ	Brightness control for LED B/L	

Remarks:

- 1) ADJ is brightness control Pin. The larger of the pulse duty is, the higher of the brightness.
- 2) ADJ signal is 0~3.3V.Operation frequency is 20KHz
- 3) GND PIN must be grounding, can not be floating.

Remarks:

Power Signal sequence:

$t1 \leq 10\text{ms}$; $1 \text{ sec} \leq t5$

$50\text{ms} \leq t2$; $200\text{ms} \leq t6$

$0 < t3 \leq 50\text{ms}$; $200\text{ms} \leq t7$

$0 < t4 \leq 10\text{ms}$

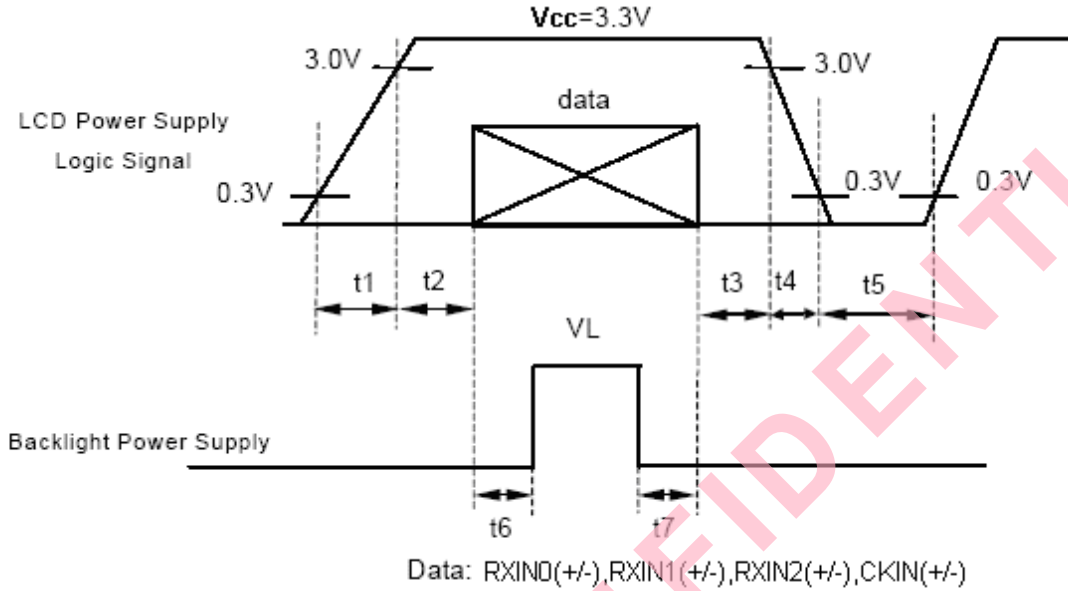

VCC-dip condition:

(1) $2.7 \text{ V} \leq VCC < 3.0\text{V}$ $t_d \leq 10 \text{ ms}$

(2) $VCC > 3.0\text{V}$. VCC-dip condition should be the same with VCC-turn-on condition °

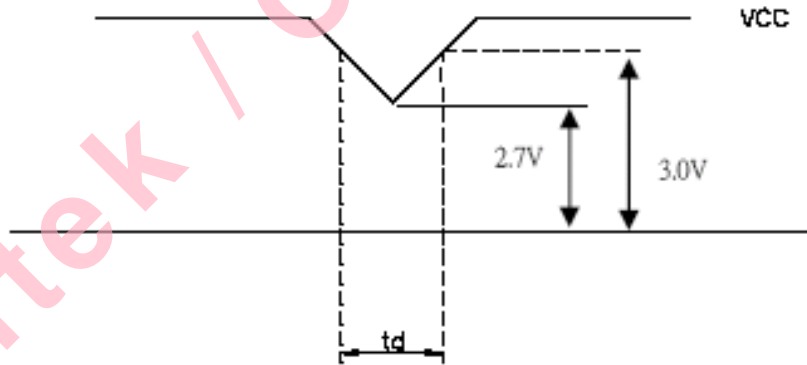

8. BLOCK DIAGRAM

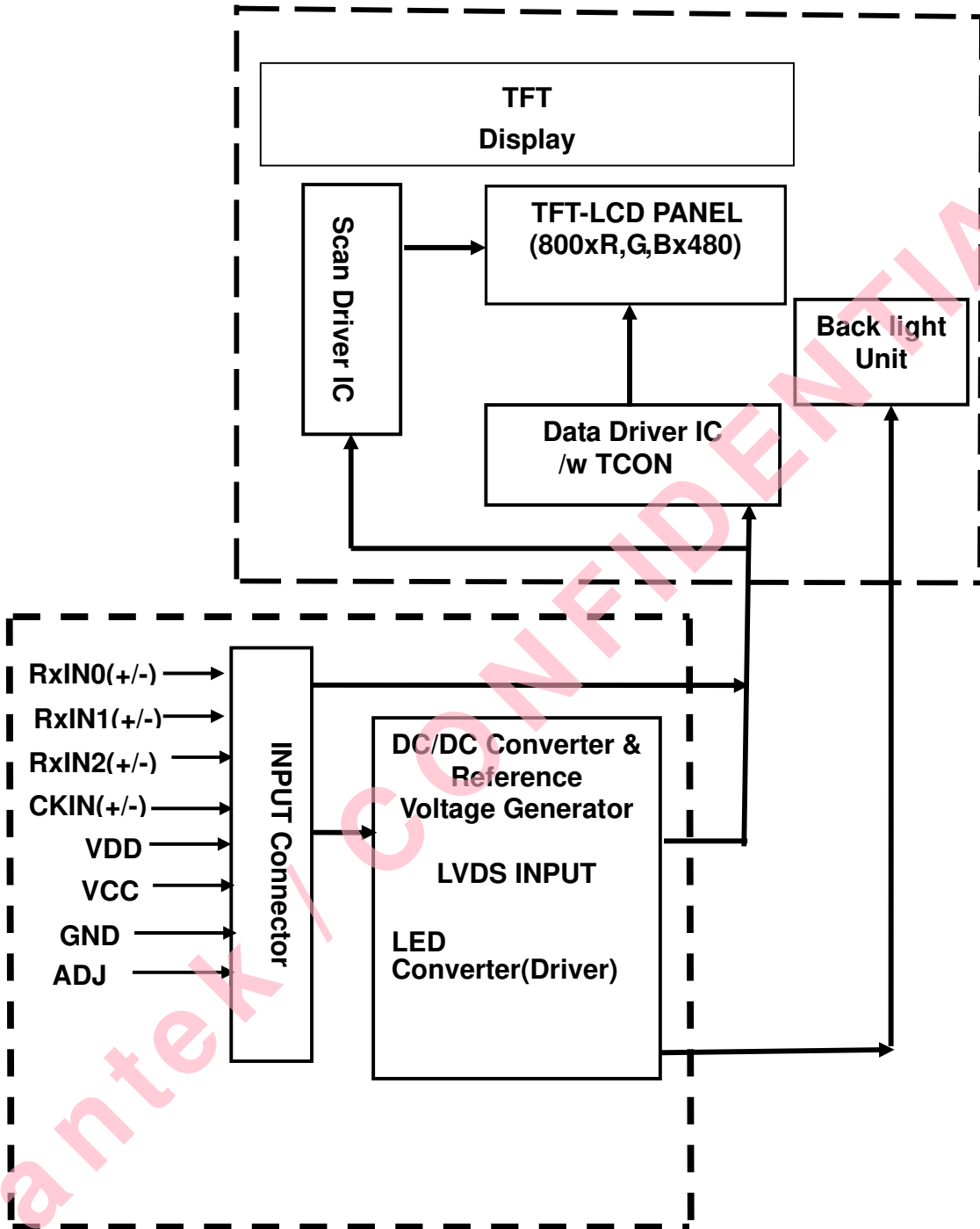

9. QUALITY ASSURANCE

9.1 Test Condition

9.1.1 Temperature and Humidity(Ambient Temperature)

Temperature : 25 ± 5°C

Humidity : 65 ± 5%

9.1.2 Operation

Unless specified otherwise, test will be conducted under function state.

9.1.3 Container

Unless specified otherwise, vibration test will be conducted to the product itself without putting it in a container.

9.1.4 Test Frequency

In case of related to deterioration such as shock test. It will be conducted only once.

9.1.5 Test Method

Reliability Test Item & Level		Test Level
No.	Test Item	
1	High Temperature Storage Test	T=80°C,240hrs
2	Low Temperature Storage Test	T=-30°C,240hrs
3	High Temperature Operation Test	T=70°C,240hrs
4	Low Temperature Operation Test	T=-20°C,240hrs
5	High Temperature and High Humidity Operation Test	T=40°C,90%RH,240hrs
6	Thermal Cycling Test (No operation)	-30°C → +25°C → +80°C, 100 Cycles 30 min 5 min 30 min
7	Vibration Test (No operation)	Frequency :10 ~ 55 Hz Amplitude :1.5 mm Sweep time : 11 mins Test Period: 6 Cycles for each direction of X, Y, Z

10. OUTLINE DRAWING

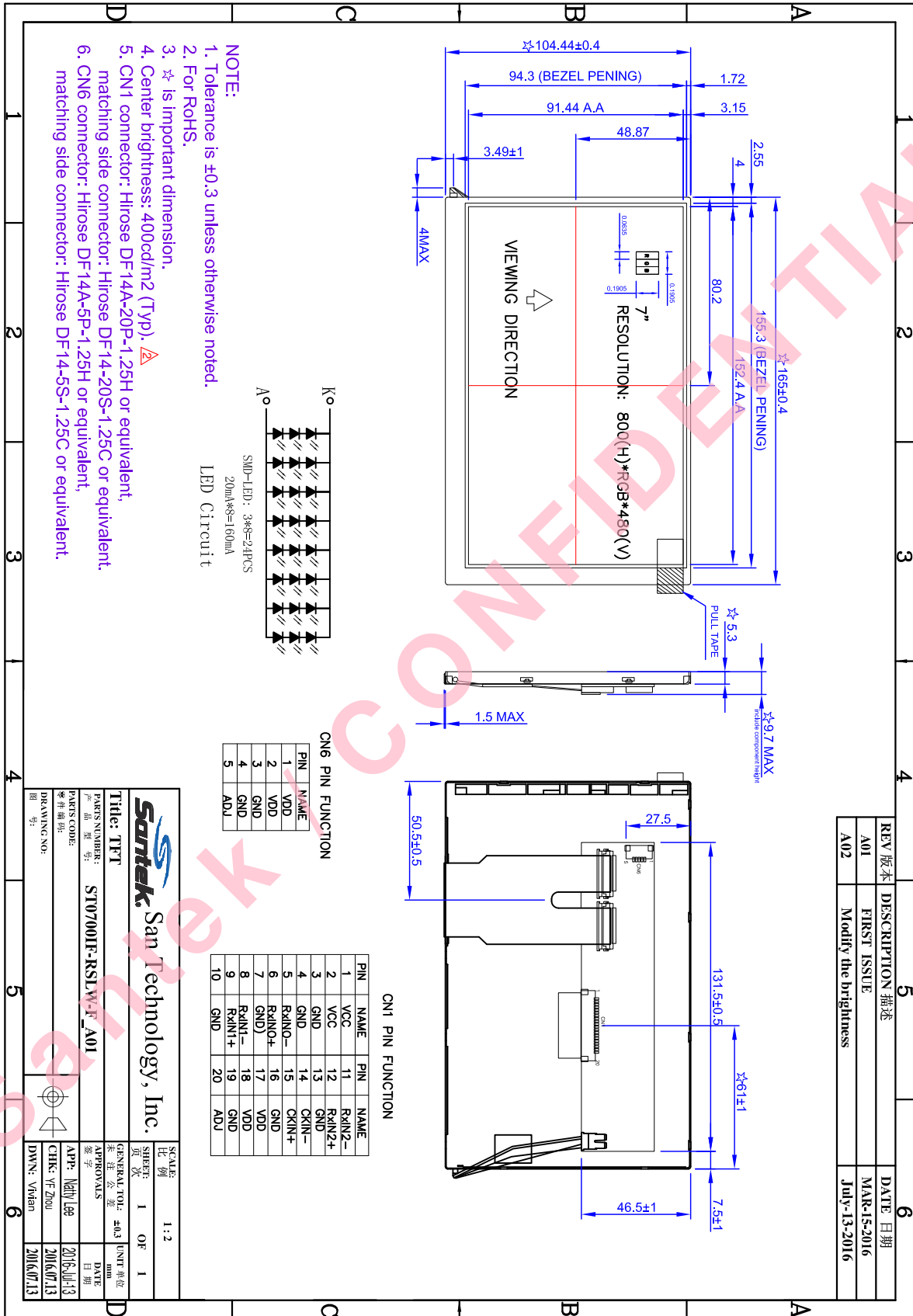

11. PACKAGE INFORMATION

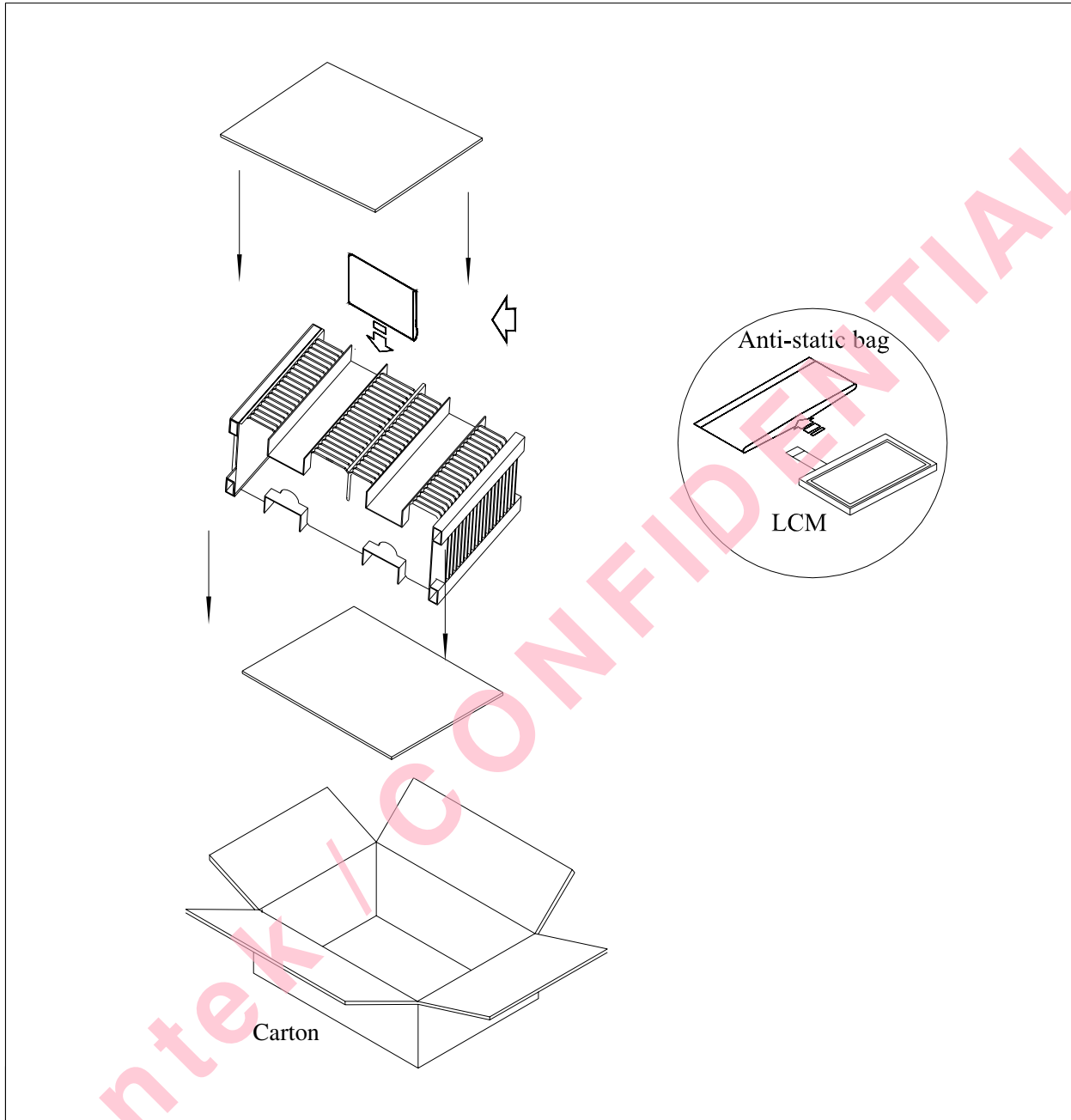

Item	Size(L*W*H)	Quantity	Note
Master Carton	482*282*279	1	
Quantity Per Master Carton		30	
N . W	4.0 (kg)	G . W	5.6 (kg)