

MATERIAL NUMBER	ALTERNATE NUMBER	STUD SIZE	"S"	"W"	PACKAGING
191390009	AA-834-04	4	.119/(3.02)	.291 (7.39)	LOOSE PIECE
191390011	AA-834-06	6	.146/(3.71)	.291 (7.39)	
191390013	AA-834-08	8	.173/(4.39)	.291 (7.39)	
191390015	AA-834-10	10	.198/(5.03)	.291 (7.39)	
191390016	AA-838-04	4	.119/(3.02)	.245 (6.23)	
191390018	AA-838-06	6	.146/(3.71)	.245 (6.23)	TAPE MOUNTED
191390010	AA-834-04T	4	.173/(4.39)	.291 (7.39)	
191390012	AA-834-06T	6	.146/(3.71)	.291 (7.39)	
191390014	AA-834-08T	8	.173/(4.39)	.291 (7.39)	
191390017	AA-838-04T	4	.119/(3.02)	.245 (6.23)	
191390019	AA-838-06T	6	.146/(3.71)	.245 (6.23)	

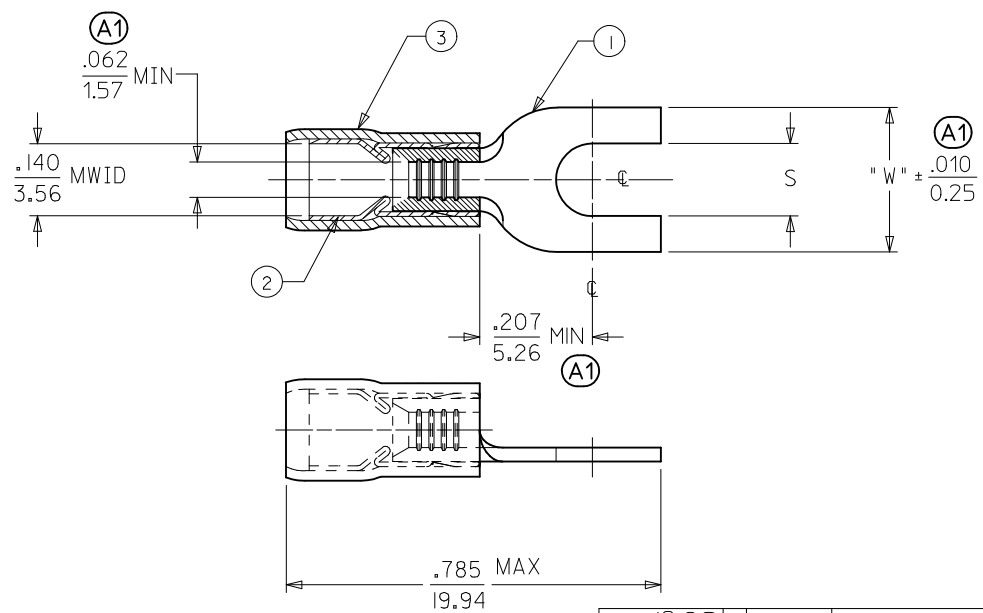
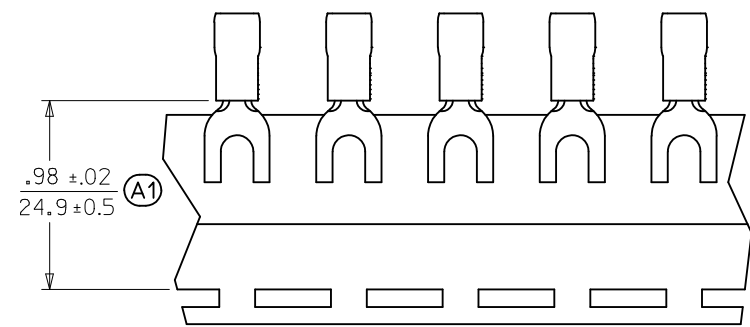

- NOTES:
 1. MATERIAL: COPPER .028 THICK
 PLATING: MATTE TIN
 2. FERRULE: TIN-PLATED BRASS
 3. INSULATION: RED NYLON
 4. MWID=MAXIMUM WIRE INSULATION DIA.
 5. PARTS ARE ROHS COMPLIANT.

CUSTOMER DRAWING

CORRECT TOLERANCES EC NO: IPG2012-0575 DRW: NETHRODAHL 2012/04/16 CHKD: JMACNEIL 2012/04/16 APPR: JMACNEIL 2012/04/19 REV: A1	QUALITY SYMBOLS ▽=0 ▽7=0	GENERAL TOLERANCES (UNLESS SPECIFIED) mm INCH 4 PLACES ± --- ± --- 3 PLACES ± --- ± .005 2 PLACES ± 0.13 ± .01 1 PLACE ± 0.25 ± --- 0 PLACE ± ±	DIMENSION STYLE IN/MM DRAWN BY DATE EDB 2000/11/17 CHECKED BY DATE HEB 2000/11/17 APPROVED BY DATE	SCALE 4:1 DESIGN UNITS INCH THIRD ANGLE PROJECTION	TITLE SPADE TONGUE TERMINAL AVIKRIMP -800 SERIES 22-18 AWG molex	MATERIAL NO. SEE CHART SIZE B	DOCUMENT NO. SD-19139-001	SHEET NO. 1 OF 1	
	ANGULAR ± --- ° DRAFT WHERE APPLICABLE MUST REMAIN WITHIN DIMENSIONS		THIS DRAWING CONTAINS INFORMATION THAT IS PROPRIETARY TO MOLEX INCORPORATED AND SHOULD NOT BE USED WITHOUT WRITTEN PERMISSION						