



# customer manual

<b>SAFETY PRECAUTIONS</b>	<b>READ THIS FIRST !</b>	2
1. INTRODUCTION		5
2. DESCRIPTION		5
2.1. Tool Specifications		6
2.2. Precautionary Information		6
3. TERMI-POINT TOOL AND CLIP SELECTION DATA		6
4. TERMI-POINT COMPONENT COLOR CODE DATA		10
5. REFERENCES		11
6. OPERATING INSTRUCTIONS		11
6.1. Installation of Mandrel		11
6.2. Removal of Mandrel		12
6.3. Tool Preparation		12
6.4. Tool Loading		13
6.5. Clip Positioning Adjustment		14
6.6. General Operating Procedure		15
6.7. Tool Unloading		17
7. PREVENTATIVE MAINTENANCE		17
8. MAINTENANCE AND ADJUSTMENTS		18
8.1. Troubleshooting		18
8.2. General Disassembly Procedure		20
8.3. General Reassembly Procedure		20
8.4. Pneumatic Assembly - Disassembly and Reassembly		20
8.5. Push Rod Replacement		21
8.6. Clearing Jammed Tool		21
8.7. Hold-Down Adjustment		22
8.8. Clip Guide Anvil Replacement		22
8.9. Post Pickups Replacement		23
8.10. Catch Spring Replacement		23
8.11. Front and Rear Catch Replacement		23
8.12. Clip Positioner Replacement		23
8.13. Wire Funnel Replacement		24
8.14. Air Line Filters and Lubricators		24
9. STORAGE		24
10. DECOMMISSIONING		24
11. REPLACEMENT AND REPAIR		24
12. REVISION SUMMARY		24
13. PARTS LISTS		25

ORIGINAL INSTRUCTIONS



## ***SAFETY PRECAUTIONS AVOID INJURY***

Safeguards are designed into this application equipment to protect operators and maintenance personnel from most hazards during equipment operation. However, certain safety precautions must be taken by the operator and repair personnel to avoid personal injury, as well as damage to the equipment. For best results, application equipment must be operated in a dry, dust-free environment. Do not operate equipment in a gaseous or hazardous environment.

- Carefully observe the following safety precautions before and during operation of the equipment:
- ALWAYS wear appropriate ear protection.
- ALWAYS wear approved eye protection when operating powered equipment.
- ALWAYS keep guard(s) in place during normal operation.
- ALWAYS insert power plug into a properly grounded receptacle to avoid electrical shock.
- ALWAYS turn off the main power switch and disconnect electrical cord from the power source when performing maintenance on the equipment.
- NEVER wear loose clothing or jewelry that may catch in moving parts of the application equipment.
- NEVER insert hands into installed application equipment.
- NEVER alter, modify, or misuse the application equipment.

## ***TOOLING ASSISTANCE CENTER***

*CALL TOLL FREE 1-800-722-1111 (CONTINENTAL UNITED STATES AND PUERTO RICO ONLY)*

The **Tooling Assistance Center** offers a means of providing technical assistance when required.

In addition, Field Service Specialists are available to provide assistance in the adjustment or repair of the application equipment when problems arise which your maintenance personnel are unable to correct.

### **INFORMATION REQUIRED WHEN CONTACTING THE TOOLING ASSISTANCE CENTER**

When calling the Tooling Assistance Center regarding service to equipment, it is suggested that a person familiar with the device be present with a copy of the manual (and drawings) to receive instructions. Many difficulties can be avoided in this manner.

When calling the Tooling Assistance Center, be ready with the following information:

1. Customer name
2. Customer address
3. Person to contact (name, title, telephone number, and extension)
4. Person calling
5. Equipment number (and serial number if applicable)
6. Product part number (and serial number if applicable)
7. Urgency of request
8. Nature of problem
9. Description of inoperative component(s)
10. Additional information/comments that may be helpful

Read this manual thoroughly before operating the machine. The performance of this machine will depend largely upon the intelligent use of the information contained in this manual.

When reading this manual, pay particular attention to **DANGER**, **CAUTION** and **NOTE** statements.



*Denotes an imminent hazard which may result in moderate or severe injury.*



*Denotes a condition which may result in product or equipment damage.*



*Highlights special or important information.*



*Do NOT use the power unit as a crushing device or for anything other than a crimping machine for the specified product. Inappropriate use of the unit could result in personal injury OR damage to the power unit.*



*Always wear approved eye protection while operating the equipment.*



*Always wear approved hearing protection while operating the equipment.*



*Read and understand the entire manual.*



*Moving parts can crush and cut.*



*Do not operate the machine if the guards are removed.*



*Always disconnect the air and lockout the tool when not in use, when performing maintenance on the tool, or when clearing a jammed tool.*



*There is a risk of whipping if a hose is not properly installed or becomes detached.*



Measurements are in metric units [followed by U.S. customary units in brackets]. Illustrations are for identification only and are not drawn to scale.



The unit should **ONLY** be operated by trained personnel.



If not using quick-disconnect fittings to connect the tool to the air supply, provide operators other means to easily disconnect the tool from the air supply.



Stored gas or fluid **MAY** be a hazard.

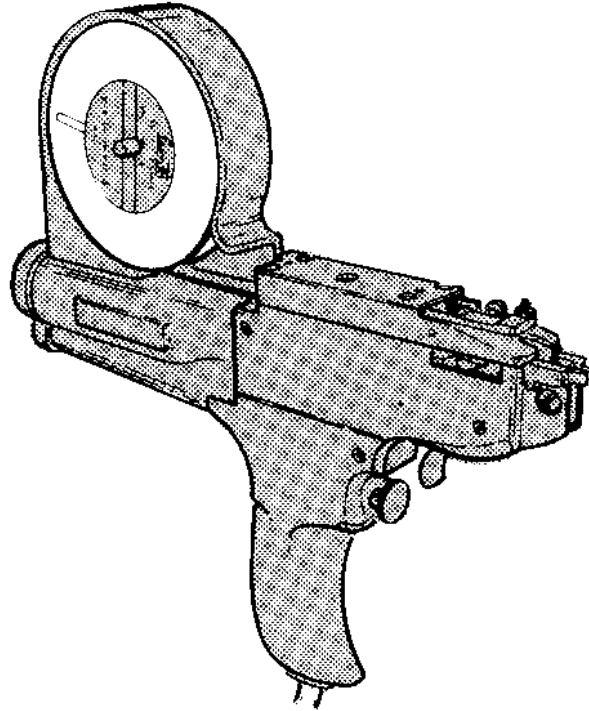

HAND OPERATED TOOLS			SEMIAUTOMATIC TOOLS		
TOOL NO.	POST SIZE	CLIPS/POST (Max)	TOOL NO.	POST SIZE	CLIPS/POST (Max)
59865-1	.022 x .036	3	59928-1	.022 x .036	3
59865-2	.031 x .062	3	59928-2	.031 x .062	3
59865-3	.031 x .093	3	59928-3	.031 x .093	3
59865-7	.031 x .062	3	59928-7	.031 x .062	3

Figure 1

## 1. INTRODUCTION

This customer manual provides general information, operation, and maintenance information for TERMI-POINT Air Tools 59865-1, -2, -3, -7 and 59928-1, -2, -3, and -7. It includes instructional, adjustment, and repair information relating to the tools.

The following instructions should be read carefully before attempting to use the tools. The performance of the tools will depend largely upon the use of the information contained in this manual. All tools and accessories are carefully tested and adjusted before shipment and, with proper maintenance and use, will give years of satisfactory service.

All illustrations and specifications contained in this manual are based on the latest product information available at the time of publication. If the information does not agree with the tool or product being used, contact your local TE Connectivity Representative or contact the Tooling Assistance Center number.

## 2. DESCRIPTION

Termini-Point air tools, with interchangeable mandrels as listed in the tool and clip selection figures, (see Figures 2 through 16), are used to terminate TE rectangular posts with Termini-Point clips. See the table in Figure 1.

The clips are automatically fed from a reel into the tool in continuous strip form. Unstripped wire, either stranded or solid, is inserted into the tool mandrel and terminated to the post with a clip.

The hand-operated tool is shown in Figure 1. The semiautomatic tools are very similar to the hand-operated tools; however a small air cylinder assembled to a bracket on the right side of the tool is used to actuate the wire funnel lever. See Figure 33.

## 2.1. Tool Specifications

The following specifications are applicable for all tools:

Air Supply Pressure - 551.6 kPa [80 psi] (min) to 655 kPa [95 psi] (max)

Tool Weight - Approximately .9 kg [2 lb.], including mandrel, fully loaded reel, and air line

Air Volume Required - 82 cu cm [5 cu in.] per cycle

Noise Level - <86dBa

Vibration - <2.5m<sup>2</sup>



*For specific dimensions on these tools, refer to the specific Customer Drawing from the TE service network. Contact the Tooling Assistance Center number.*

## 2.2. Precautionary Information

The following precautions must be observed when using these tools:



*Do not exceed maximum air line pressure of 655 kPa [95 psi], or tool damage may occur. If shop air pressure exceeds 655 kPa [95 psi], use an air regulator. Refer to Paragraph 8.14. Also, for proper functioning of the tool, air line pressure should never fall below 551.6 kPa [80 psi] during terminating cycles.*



*Disconnect or turn off air pressure, as instructed in the procedures, when changing tooling or performing any maintenance on the tool.*



*Never hold the nose of the tool against the hand or body when squeezing the trigger. The tool nose must be clear of all objects, or properly positioned on the terminal post, when the tool is actuated.*



*Never cycle the tool without having the side cover and top cover securely installed on the tool.*



*Before operating the tool, be sure that the compatible post, clip, wire, and wire insulation are being used.*

It is also recommended that quick-disconnect fittings are used to connect the tool to the air supply. If not using quick-disconnect fittings, provide a pneumatic lock-out on the air line that bleeds air after it is turned off.

## 3. TERMI-POINT TOOL AND CLIP SELECTION DATA

The following information is used to determine the proper tool, mandrel and clip for this TE post and the wire being used. After post size, wire size, and insulation diameter range have been established, select the desired tool and mandrel. Then, select the proper clip for the post, wire, and tool mandrel combination. The clips and mandrels are color-coded to visually check component compatibility (i.e., red clip - red mandrel, orange clip - orange mandrel, etc.).

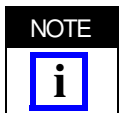

*For wire, clip, and tooling combinations other than those listed, contact your TE Representative or the Tooling Assistance Center.*

## PNEUMATIC TOOLS 59865-2 and 59865-7 FOR POST SIZE .031 X .062 SYSTEM

WIRE SIZE (7-Stranded or Solid)	INSULATION DIAMETER RANGE	MANDREL NUMBER	CLIP NUMBER (2800 PER REEL)			MANDREL AND CLIP COLOR CODE
			TIN PLATED	GOLD PLATED	TIN-NICKEL PLATED	
22	0.99-1.24 [.039-.049]	69659-7	4-330495-2	4-330495-9	6-330495-8	Orange
	1.14-1.50 [.045-.059]	69659-1				
	1.40-1.65 [.055-.065]	1-69659-0				
24	0.84-1.24 [.033-.049]	69659-8	2-330495-1	2-330495-2	6-330495-4	Red
	1.14-1.50 [.045-.059]	69659				
	1.40-1.65 [.055-.065]	1-69659-1				
26	0.71-0.99 [.028-.039]	1-69659-5	1-330495-3	1-330495-8	8-330495-4	Brown
	0.84-1.24 [.033-.049]	69659-9				
	1.14-1.50 [.045-.059]	69659-3				
28	0.61-1.24 [.024-.039]	1-69659-8	3-330495-5	9-330495-6	8-330495-8	Black
	0.84-1.24 [.033-.049]	69659-2				

Figure 2

## PNEUMATIC TOOLS 599285-2 and 59928-7 FOR POST SIZE .031 X .062 SYSTEM

WIRE SIZE (7-Stranded or Solid)	INSULATION DIAMETER RANGE	MANDREL NUMBER	CLIP NUMBER (2800 PER REEL)			MANDREL AND CLIP COLOR CODE
			TIN PLATED	GOLD PLATED	TIN-NICKEL PLATED	
22	0.99-1.24 [.039-.049]	265070-1	4-330495-2	4-330495-9	6-330495-8	Orange
	1.14-1.50 [.045-.059]	265070-2				
	1.40-1.65 [.055-.065]	265070-3				
24	0.84-1.24 [.033-.049]	265070-4	2-330495-1	2-330495-2	6-330495-4	Red
	1.14-1.50 [.045-.059]	265070-5				
	1.40-1.65 [.055-.065]	265070-6				
26	0.71-1.24 [.028-.049]	265070-7	1-330495-3	1-330495-8	8-330495-4	Brown
	1.14-1.50 [.045-.059]	265070-8				
28	0.61-1.24 [.024-.039]	265070-9	3-330495-5	9-330495-6	8-330495-8	Black
	0.84-1.24 [.033-.049]	1-265070-0				

Figure 3

## PNEUMATIC TOOLS 59865-2, 59865-7, 59928-2, 59928-7, 58117-1 FOR POST SIZE .031 X .062 SYSTEM

WIRE SIZE (7-Stranded or Solid)	INSULATION DIAMETER RANGE	MANDREL NUMBER	CLIP NUMBER (2800 PER REEL)			MANDREL AND CLIP COLOR CODE
			TIN PLATED	GOLD PLATED	TIN-NICKEL PLATED	
22	0.91-1.65 [.036-.065]	311078-1	4-330495-2	4-330495-9	6-330495-8	Orange
24	0.86-1.65 [.034-.065]	311078-2	2-330495-1	2-330495-2	6-330495-4	Red
26	0.76-1.40 [.030-.055]	311078-3	1-330495-3	1-330495-8	8-330495-4	Brown
28	0.56-0.91 [.022-.036]	311078-4	3-330495-5	9-330495-6	8-330495-8	Black

Figure 4

Tool No. 59865-2 and 59928-2 may be used only with wire sizes 24-28.

MANUAL SERVICE TOOL 69526-2 FOR POST SIZE .031 X .062 SYSTEM

WIRE SIZE (7-Stranded or Solid)	INSULATION DIAMETER RANGE	MANDREL NUMBER	CLIP NUMBER (1000 PER REEL)			MANDREL AND CLIP COLOR CODE
			TIN PLATED	GOLD PLATED	TIN-NICKEL PLATED	
22	0.99-1.14 [.039-.045]	69551-8	6-330495-1	6-330495-2	6-330495-7	Orange
	1.14-1.65 [.045-.065]	1-69411-4				
24	0.84-1.14 [.033-.045]	69551-9	5-330495-3	1-330495-9	6-330495-3	Red
	1.14-1.65 [.045-.065]	1-69411-3				
26	0.71-1.14 [.028-.045]	69551-6	5-330495-5	9-330495-8	8-330495-6	Brown
	1.14-1.40 [.045-.055]	1-69411-9				
28	0.61-1.14 [.024-.045]	69551-5	5-330495-9	330495-3	9-330495-0	Black

Figure 5

MANUAL SERVICE TOOL 69525-1 FOR POST SIZE .031 X .062 SYSTEM

WIRE SIZE (7-Stranded or Solid)	INSULATION DIAMETER RANGE	MANDREL NUMBER	CLIP NUMBER (40 STRIPS, 25 EACH)			MANDREL AND CLIP COLOR CODE
			TIN PLATED	GOLD PLATED	TIN-NICKEL PLATED	
22	0.99-1.14 [.039-.045]	69551-8	4-330495-4	5-330495-1	6-330495-9	Orange
	1.14-1.65 [.045-.065]	1-69411-4				
24	0.84-1.14 [.033-.045]	69551-9	2-330495-4	4-330495-8	330495-4	Red
	1.14-1.65 [.045-.065]	1-69411-3				
26	0.71-1.14 [.028-.045]	69551-6	1-330495-5	9-330495-9	8-330495-5	Brown
	1.14-1.40 [.045-.055]	1-69411-9				
28	0.61-1.14 [.024-.045]	69551-5	3-330495-7	330495-1	8-330495-9	Black

Figure 6

AUTOMATIC WIRING FOR POST SIZE .031 X .062 SYSTEM

WIRE SIZE (7-Stranded or Solid)	MANDREL NUMBER FOR TERMINATING UNIT 266266-[ ]	CLIP NUMBER (100,000 PER REEL)			MANDREL AND CLIP COLOR CODE
		TIN PLATED	GOLD PLATED	TIN-NICKEL PLATED	
24	265840-6	2-330495-6	4-330495-7	6-330495-6	Red
26	265840-7	1-330495-7	330495-2	8-330495-7	Brown
28	265840-8	3-330495-9	9-330495-7	9-330495-1	Black

Figure 7

MANUAL SERVICE TOOL 69535 AND PNEUMATIC TOOL 59865-1 FOR POST SIZE .022 X .036 SYSTEM

WIRE SIZE (7-Stranded or Solid)	INSULATION DIAMETER RANGE	MANDREL INSERT NUMBER	CLIP NUMBER (2500 PER REEL)			MANDREL COLOR CODE
			TIN PLATED	GOLD PLATED	TIN-NICKEL PLATED	
28	0.46-0.74 [.018-.029]	69545-1	3-67042-4	67042-2	67042-1	Black
30		69545-3				White
32		69545-2				Gray

Figure 8



PNEUMATIC TOOS 59865-1, 59928-1, 58118-1, AND 58119-1 FOR POST SIZE .022 X .036 SYSTEM

WIRE SIZE (7-Stranded or Solid)	INSULATION DIAMETER RANGE	MANDREL INSERT NUMBER	CLIP NUMBER (2500 PER REEL)			MANDREL COLOR CODE
			TIN PLATED	GOLD PLATED	TIN-NICKEL PLATED	
28	0.46-0.74 [.018-.029]	59998-1	3-67042-4	67042-2	67042-1	Black
30		59998-2				White
32		59998-3				Gray

Figure 9

PNEUMATIC TOOS 59928-1 AND 59865-1 FOR POST SIZE .022 X .036 SYSTEM

WIRE SIZE (7-Stranded or Solid)	INSULATION DIAMETER RANGE	MANDREL INSERT NUMBER	CLIP NUMBER (2500 PER REEL)			MANDREL COLOR CODE
			TIN PLATED	GOLD PLATED	TIN-NICKEL PLATED	
28	0.46-0.74 [.018-.029]	69545-8	3-67042-4	67042-2	67042-1	Black
30		69545-9				White
32		1-69545-2				Gray

Figure 10

MANUAL SERVICE TOOL 69535-1 FOR POST SIZE .022 X .036 SYSTEM

WIRE SIZE (7-Stranded or Solid)	INSULATION DIAMETER RANGE	MANDREL INSERT NUMBER	CLIP NUMBER (100 PER REEL)			MANDREL COLOR CODE
			TIN PLATED	GOLD PLATED	TIN-NICKEL PLATED	
28	0.46-0.74 [.018-.029]	69545-1	3-67042-6	1-67042-6	1-67042-7	Black
30		69545-3				White
32		69545-2				Gray

Figure 11

AUTOMATIC WIRING FOR POST SIZE .022 X .036 SYSTEM

WIRE SIZE (7-Stranded or Solid)	MANDREL NUMBER FOR TERMINATING UNIT 265945-6	CLIP NUMBER (100,000 PER REEL)			MANDREL AND CLIP COLOR CODE
		TIN PLATED	GOLD PLATED	TIN-NICKEL PLATED	
28	265841-1	3-67042-5	67042-7	67042-6	Black
30	265841-2				White

Figure 12

PNEUMATIC TOOL 69585-1 FOR POST SIZE .031 X .093 SYSTEM

WIRE SIZE (7-Stranded or Solid)	INSULATION DIAMETER RANGE	MANDREL NUMBER	CLIP NUMBER (1000 PER REEL)		MANDREL AND CLIP COLOR CODE
			UNPLATED	ELECTRO-TIN PLATED	
20	1.42-1.65 [.056-.065]	69542-6	2-330854-3	2-330854-6	Yellow
	1.68-1.90 [.066-.075]	69542			
	1.93-2.16 [.076-.085]	69542-1			
24	1.42-1.65 [.056-.065]	69542-8	3-330854-2	2-330854-9	Red
	1.68-1.90 [.066-.075]	69542-5			
	1.93-2.16 [.076-.085]	69542-3			

Figure 13

PNEUMATIC TOOLS 59865-3 AND 59928-3 FOR POST SIZE .031 X .093 SYSTEM					
WIRE SIZE (7-Stranded or Solid)	INSULATION DIAMETER RANGE	MANDREL NUMBER	CLIP NUMBER (1000 PER REEL)		MANDREL AND CLIP COLOR CODE
			UNPLATED	ELECTRO-TIN PLATED	
20	0.91-1.65 [.036-.065]	311079-1	2-330854-3	2-330854-6	Yellow
24	0.86-1.65 [.034-.065]	311079-2	3-330854-2	2-330854-9	Red

Figure 14

STRIP FED MANUAL SERVICE TOOL 69702 FOR POST SIZE .031 X .062 SYSTEM				
WIRE SIZE (7-Stranded or Solid)	INSULATION DIAMETER RANGE	MANDREL NUMBER	CLIP NUMBER (40 STRIPS, 25 EACH)	MANDREL AND CLIP COLOR CODE
			TIN-NICKEL PLATED	
20	1.17-1.65 [.046-.065]	69561	2-330854-4	Yellow
	1.68-2.16 [.066-.085]	69561-1		
24	1.40-1.65 [.055-.065]	69561-4	4-330854-1	Red

Figure 15

RELATED TOOLING								
PULL TEST TOOL				CLIP EXTRACTION TOOL			TERMI-TWIST* POST REPLACEMENT TOOL	
NUMBER	TEST FORCE	INDICATOR RING COLOR	SYSTEM	NUMBER	TYPE	SYSTEM	NUMBER	POST SIZE
69358-2	10 N [2.25 lbf]	Yellow	.031 x .062	69357-3	Extraction and Positioning	.031 x .062	265831-3	.031 x .062
69358-6	2.2 N [0.50 lbf]	Green	.022 x .036	69445	Captive		265831-1	.022 x .036
69358-5	10 N [2.25 lbf]	Yellow	.031 x .093	69357-5	Extraction and Positioning	.022 x .036	69514-2	.031 x .093

Figure 16

4. TERMI-POINT COMPONENT COLOR CODE DATA

Termi-Point .031 x .062 in. mandrels, mandrel inserts, clips and clip containers are color coded to aid the operator in matching clips and mandrel assemblies. See Figure 17.

.031 X .062		MANDREL AND CLIP COLOR CODE	.022 X .036		MANDRE COLOR CODE	.031 X .093		MANDREL AND CLIP COLOR CODE
Wire Size (7-Stranded or Solid)	28	Black	Wire Size (7-Stranded or Solid)	32	Gray	Wire Size (7-Stranded or Solid)	20	Yellow
	26	Brown		30	White		24	Red
	24	Red		28	Black		---	---
	22	Orange		---	---		---	---

Figure 17

For code location (Clip Identification Label), the color code will appear on the label, containing the part number and quantity, affixed to the clip reel or tube. The clip is identified by a colored dot or stripe on the crown of the clip. The mandrels and mandrel inserts will be color coded as shown. Exact location may vary due to differences in mandrel design. See Figure 18.

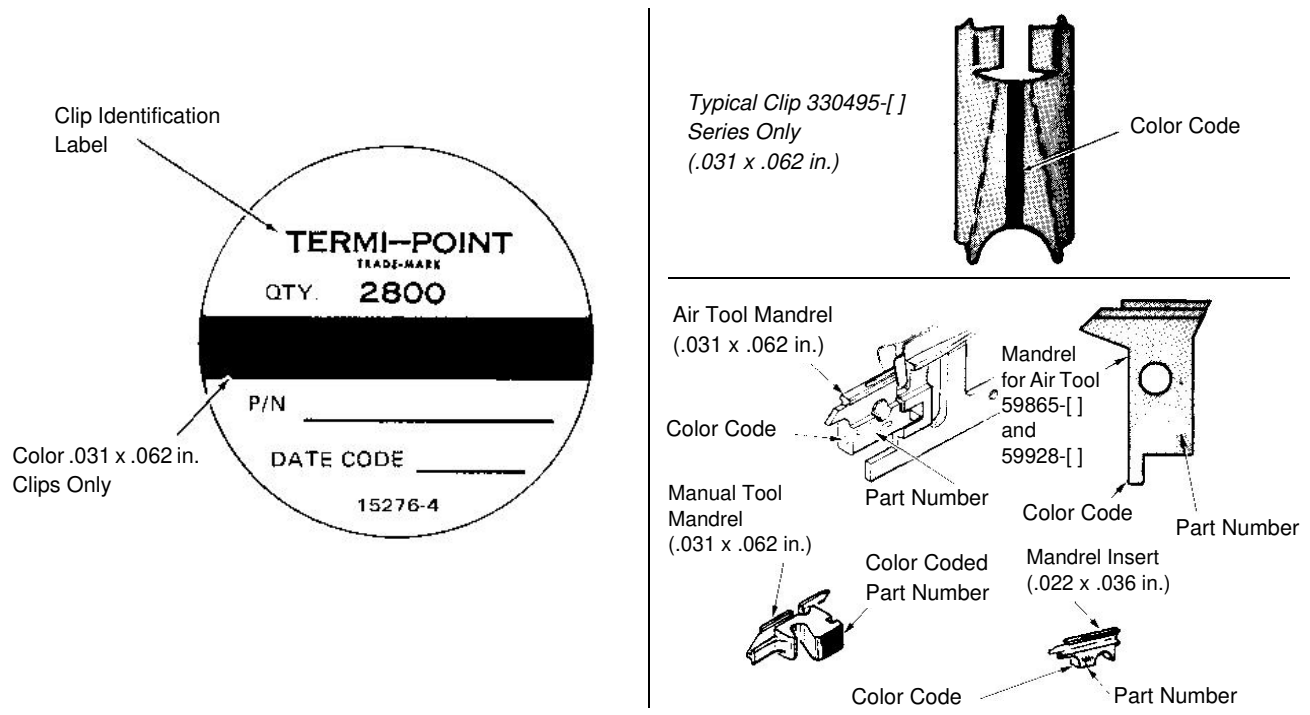

Figure 18

5. REFERENCES

The following instruction sheets provide related information for the TERMI-POINT Air Tools:

- 408-1920 (Quality Control Procedure for TERMI-POINT Clip Applications)
- 408-1933 (TERMI-POINT Pull Test Tool No. 69358 and Test Tip 69544)
- 408-1942 (TERMI-POINT Extraction Tool 69357)
- 408-2019 (Operator’s Quality Check Procedure for TERMI-POINT Clip Application)
- 408-2221 (New Tool Warranty and Exchange Policy for TERMI-POINT Tooling)
- 408-2370 (TERMI-POINT Tool Mandrel Maintenance and Repair)

6. OPERATING INSTRUCTIONS

6.1. Installation of Mandrel

1. Disconnect tool from factory air supply
2. Select correct mandrel for wire size and clips being used. Refer to Section 3. Make sure the color code data for the mandrel, clips, and wire size are compatible.
3. Remove tooling foot by removing two screws. See Figure 19.
4. Remove mandrel holding screw.
5. Open both post pickups and insert mandrel; align hole in mandrel with mandrel holding screw hole, as shown in Figure 19.



*Use care not to push against stripping ear area of mandrel so as not to damage cutting edge of mandrel.*

6. Release post pickups and insert and tighten mandrel holding shoulder screw.
7. Re-install tooling foot with two screws.

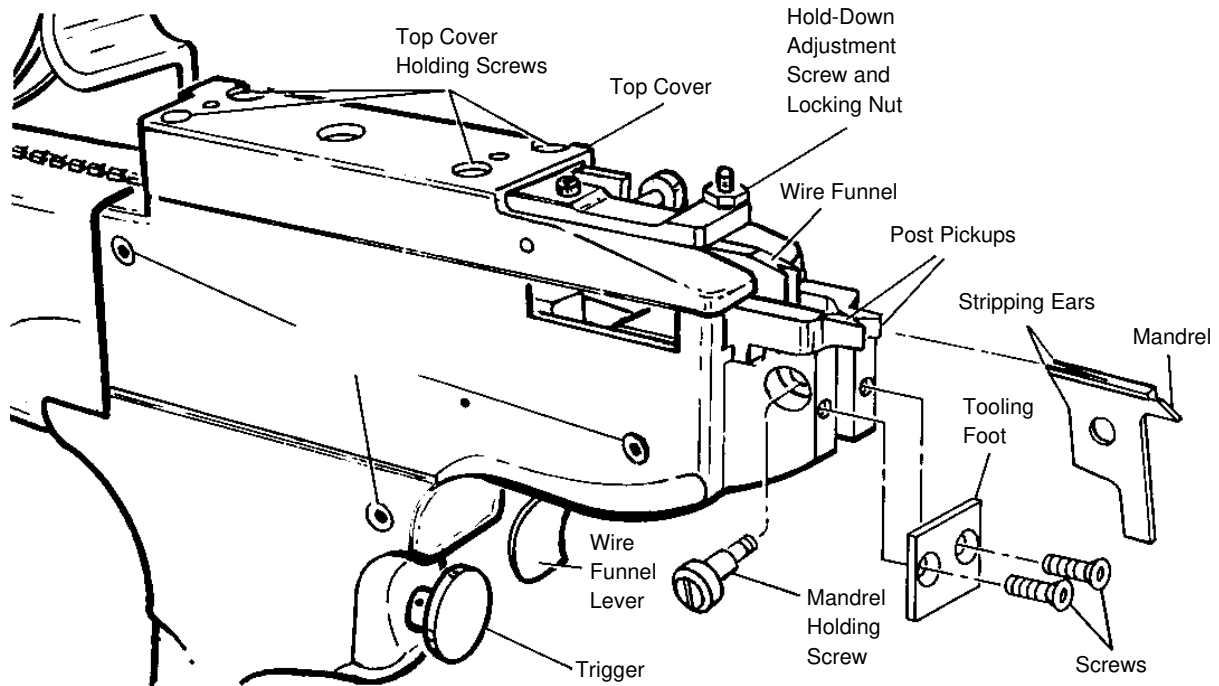

Figure 19

## 6.2. Removal of Mandrel

1. Disconnect tool from factory air supply.
2. Remove tooling foot by removing two screws.
3. Remove mandrel holding shoulder screw (see Figure 19).
4. Open both post pickups, grasp front of mandrel, and carefully pull mandrel out of tool.



*Use care not to push against stripping ear area of mandrel; doing so may damage cutting edge of mandrel.*

5. Release post pickups and insert mandrel holding shoulder screw; do not tighten screw.
6. Re-install tooling foot with two screws.

## 6.3. Tool Preparation

1. Hold tool securely in either hand, with index finger positioned over trigger. Become familiar with weight and feel of tool, while practicing aiming movement.
2. Place index finger on wire funnel lever (directly above trigger as shown in Figure 19) and operate wire funnel lever several times. Note that as lever is pulled, wire funnel on top of tool (Figure 19) moves back and, as lever is released, wire funnel moves forward. In operation, this permits wire to be properly positioned in tool and clamped in place for termination cycle.
3. With clips loaded (Paragraph 6.4) and mandrel installed (Paragraph 6.1), connect tool to air supply (551.6 kPa [80 psi], min to 655 kPa [95 psi], max., Paragraph 2.1).



*Never hold nose of tool against hand or body when squeezing trigger. Tool nose must be clear of all objects, or properly positioned on terminal post, when tool is actuated.*

4. Squeeze trigger firmly to initiate a termination cycle. Hold trigger approximately one second before releasing trigger. Practice to achieve smooth trigger control and to overcome tendency to flinch. Note that termination cycle is completed each time trigger is squeezed.
5. Refer to Paragraph 6.5 for clip positioning instructions and to Paragraph 6.6 for general operating procedures.

#### 6.4. Tool Loading

1. Disconnect tool from factory air supply.
2. Obtain full clip reel of correct clips for tool, mandrel, and wire size being used. Refer to Section 3, and ensure that tool, mandrel, clips and wire size being used are compatible.
3. Free the exposed end of clip train on reel and place full reel into reel holder with clips feeding from bottom of reel. Ensure that clips are straight and that insulation supports on clips face forward front of tool. Refer to Figure 20.

**NOTE** *Spindle of reel holder locks reel in place.*



4. Feed clip train into opening in rear of push rod (see Figure 20) and, using a scribe, continue to feed until clips cannot advance any further; do not force clip train.
5. Connect tool to air supply.
6. Set clip positioner (left side of tool, Figure 22) to “B”.
7. Hold tool in left hand, squeeze but do not release trigger. Push rod will move forward and stay forward as long as trigger is held.

**NOTE** *With push rod forward, front of clip train is visible, on tail of clip guide anvil, through window on right side of tool (see Figure 21).*

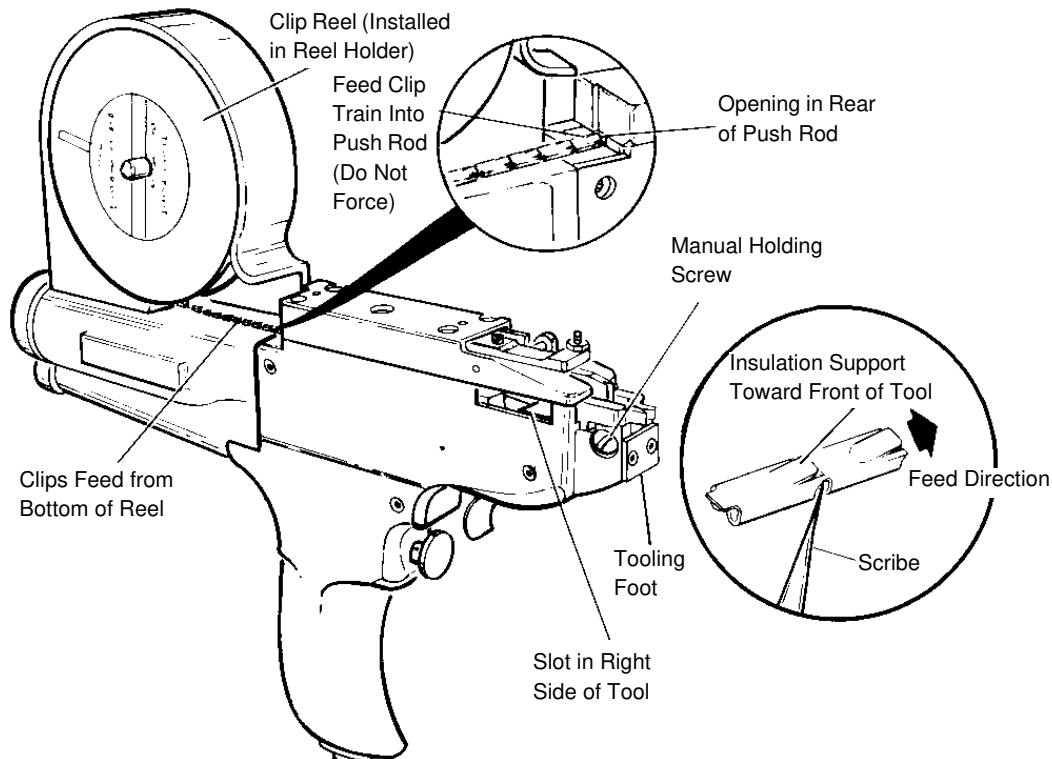



Figure 20

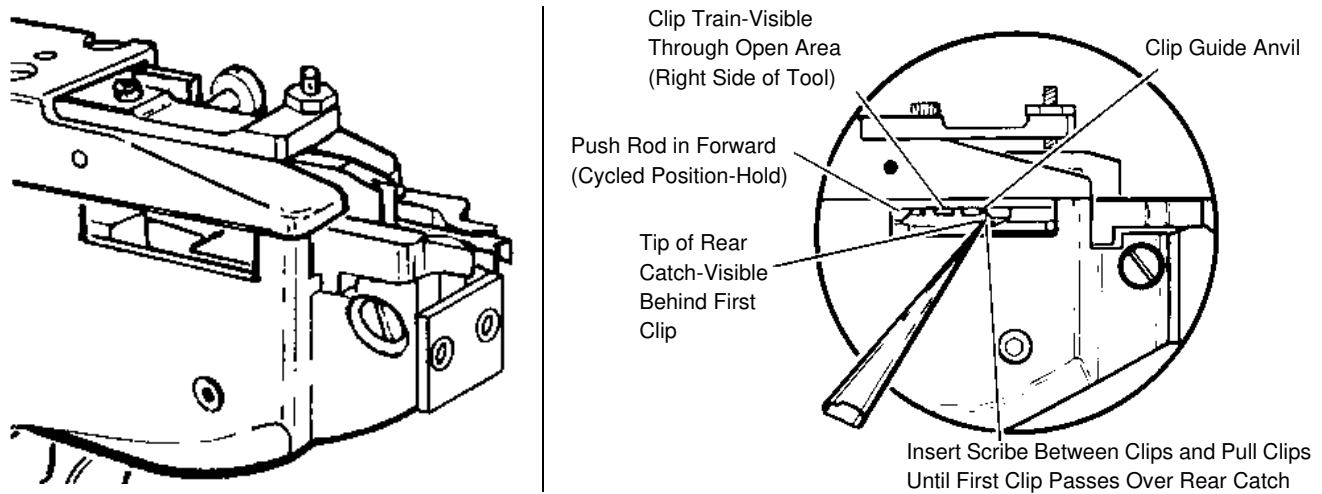

Figure 21

8. Insert scribe through window or right side of tool and move clips forward over clip guide anvil until first clip passes over rear catch and rear catch “clicks” into position behind first clip.

**NOTE** *Front catch of tool stops clip train as soon as first clip passes over rear catch.*

9. Remove scribe from tool and then release trigger. Push rod will fully retract.

10. Again squeeze but do not release trigger. Push rod will move forward and, if tool is correctly loaded, will carry one clip with it. Check that clip is released from push rod and then release trigger. If tool has not been correctly loaded (no clip present in push rod), repeat steps (7) through (10) and in step (8) be sure that rear catch “clicks” into position behind first clip.

### 6.5. Clip Positioning Adjustment

The clip positioning adjustment consists of a positioner dial marked with the letters “A”, “B”, and “C”. See Figure 22. A detent within the positioner dial, together with spring tension applied to the internal clip positioner, causes the positioner dial to “click” into the selected setting with applicable letter at top of dial. The setting of the positioner dial determines the distance the clip travels as it is applied to the post. The tool push rod pushes the clip onto the post the shortest distance in the “C” setting and the longest distance in the “A” setting. See Figure 22. Select appropriate clip positioning setting for each termination before inserting wire into tool.

**NOTE** *Ensure that clip positioner dial is properly positioned in detent on selected setting (letter squarely on top of dial). Do not squeeze trigger with positioner dial out of detent position (between letters).*

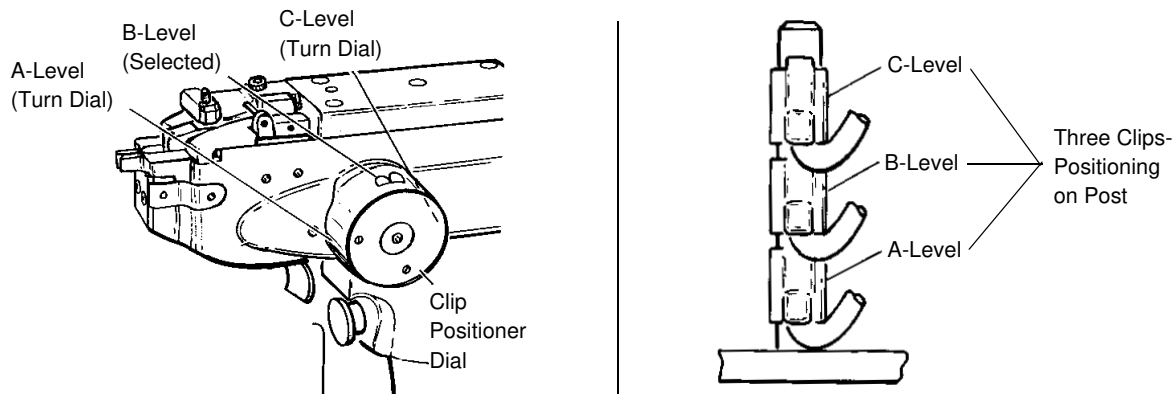

Figure 22

## 6.6. General Operating Procedure

1. Set clip positioner for setting required for desired clip level. See Figure 22.

**NOTE** *Ensure that positioner dial is engaged in detent with selected letter at top of dial.*

**i**

2. Pull wire funnel lever to pull wire funnel back: do not release lever.

3. Insert end of wire (unstripped) through wire funnel into opening between clip guide anvil and mandrel until wire bottoms. See Figure 23.

**NOTE** *Wire bottoms on surface formed by the meeting of projections on left and right post pickups.*

**i**

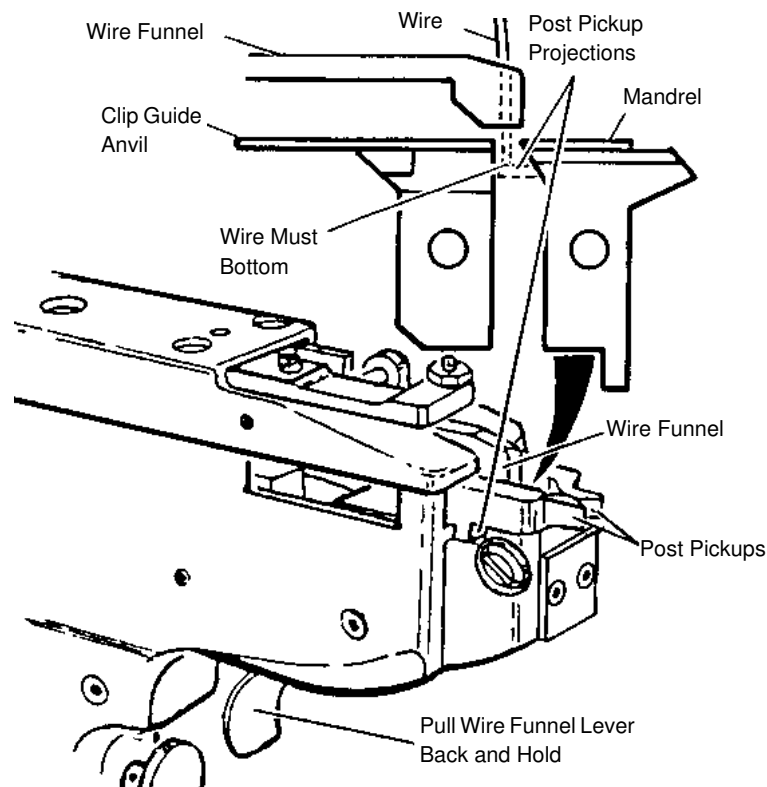

Figure 23

4. With wire bottomed, release wire funnel lever first, clamping wire in place in tool, and then release wire.

5. Position post pickups of tool over selected post on pc board or panel, visually align mandrel of tool with post, insert post into post pickups until post is positioned against mandrel, and position wire to right or left, depending on desired wire routing. See Figure 24.

6. Hold tool firmly against end of post. Apply approximately 22.2 N [5 lbs] of pressure and, keeping tool in alignment with post, squeeze trigger with index finger. Maintain trigger pressure until forward motion of push rod stops (clip positioned at selected level on post), and then pull tool away from pc board or panel before releasing trigger.

**NOTE** *A pressure of approximately 22.2 N [5 lbs] must be exerted by the operator against the post while applying the clip. This pressure is needed to overcome the recoil action of the tool when the clip is applied to the post. Experience in tool operation will enable the operator to apply the required pressure instinctively during the clip application process.*

**i**

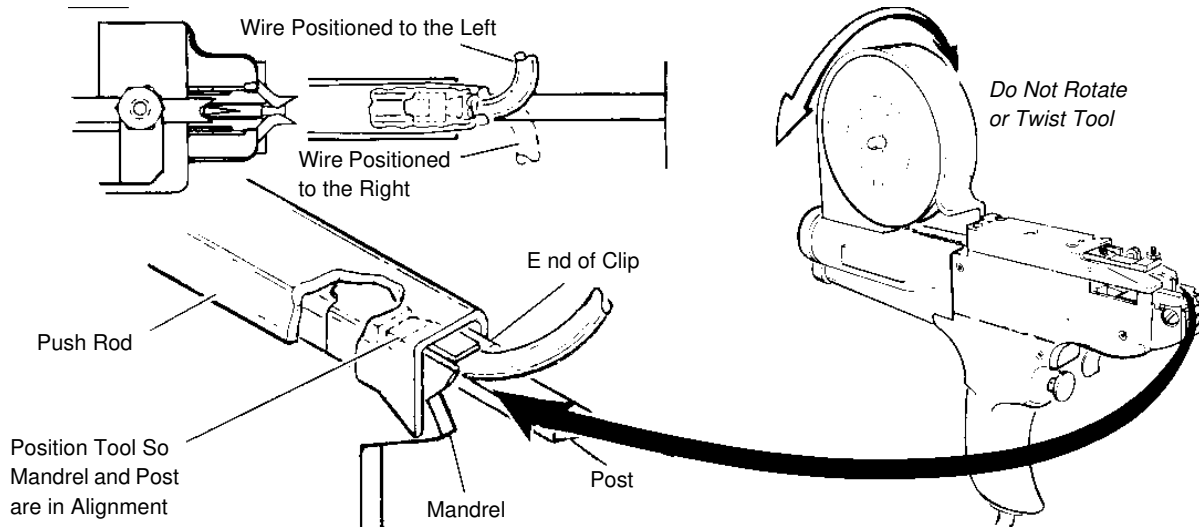

Figure 24

7. Inspect termination. A properly terminated post should appear as shown in Figures 25 and 26. For operator's quality check procedure, refer to Instruction Sheet 408-2019. Also refer to MIL-STD-1664A (EC).



Wire insulation strippings are collected in hollow handle of tool. Periodically remove insulation strippings by pivoting cover plate on handle. See Figure 27.

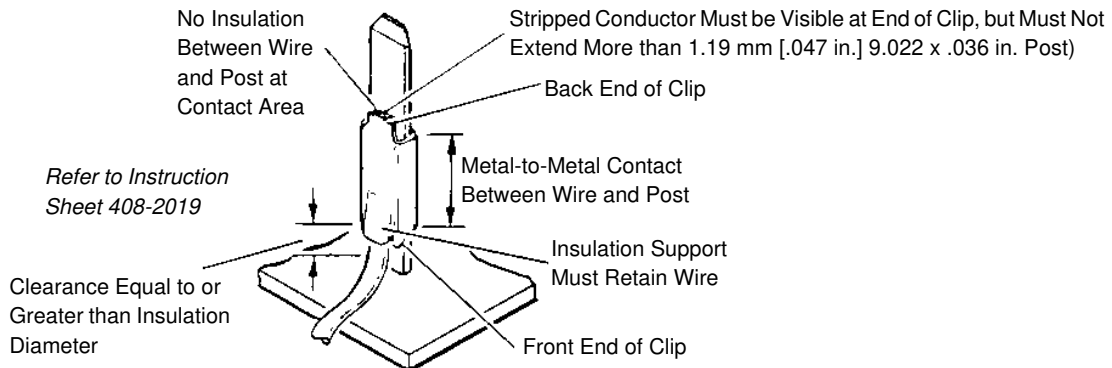

Figure 25

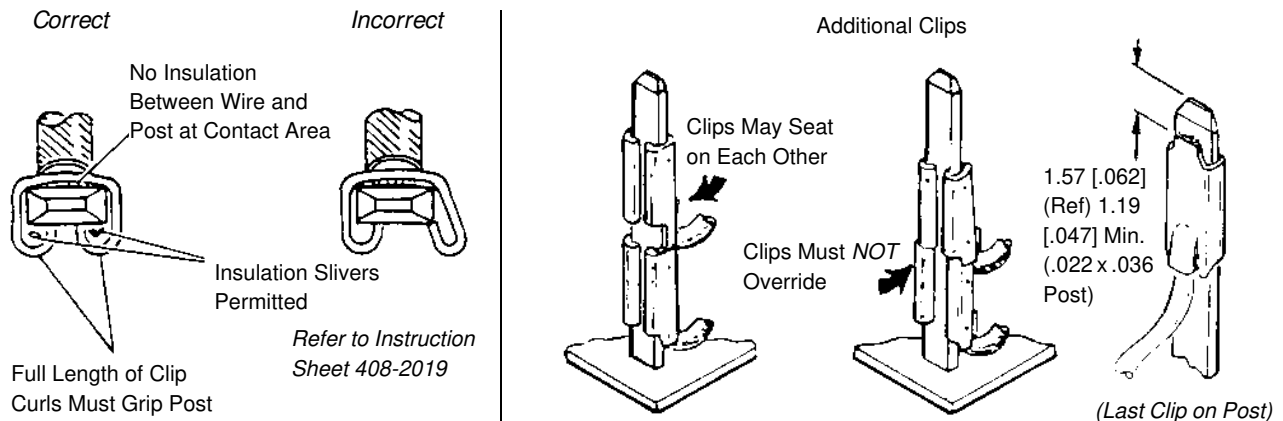

Figure 26



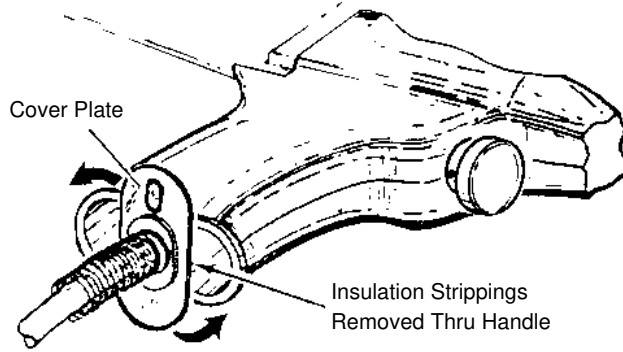

Figure 27

6.7. Tool Unloading

1. Break clip train at a convenient point between tool top cover and reel bracket.



*Clips now in clip train feeding into tool, if not used in operation, will be lost in unloading.*

2. With air supply connected, operate tool by squeezing trigger to advance clip train, and continue to squeeze trigger until tool is unloaded (no more clips come out of tool).
3. Squeeze spindle of reel holder, insert fingers through holes provided in back of reel holder, and push reel out of reel holder.
4. Wind clips back onto reel and return reel to suitable storage.

7. PREVENTATIVE MAINTENANCE

Check the following items periodically (weekly, minimum) to ensure proper operating efficiency of your TERMI-POINT air tool. Minor repairs, adjustments, and parts replacement instructions are provided in Section 8. For major repairs, replacement parts, and factory service, contact your local TE Representative.

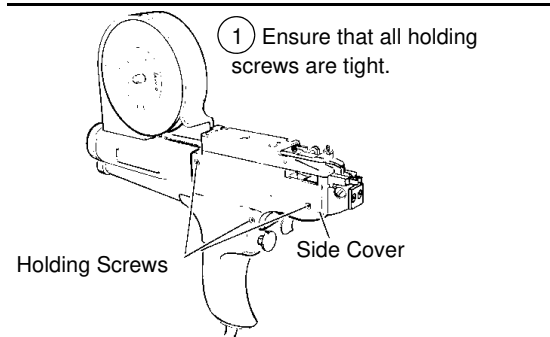

- 1 Ensure that all holding screws are tight.

- 3 Remove mandrel (Para. 6.1 and 6.2). Ensure passageway for insulation strippings into hollow handle is clear. If area is obstructed, perform general disassembly (Para 8.2) and clean out insulation strip-pings and/or metal chips. Check mandrel (Step 4) and then reinstall mandrel.

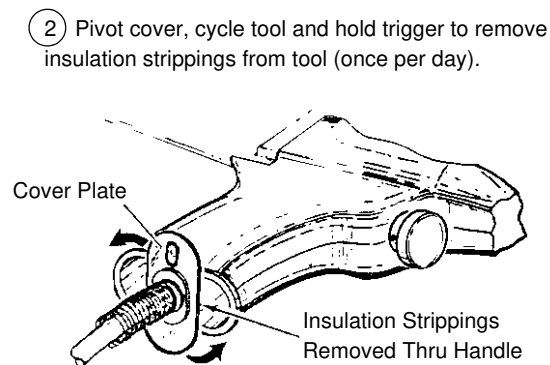
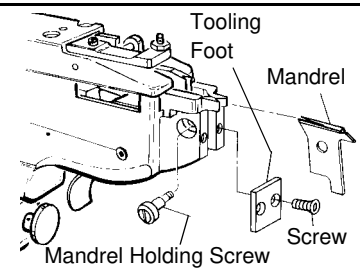

- 2 Pivot cover, cycle tool and hold trigger to remove insulation strippings from tool (once per day).

- 4 Check mandrel for burrs or nicks. For detailed instructions on mandrel maintenance, refer to 408-2370.

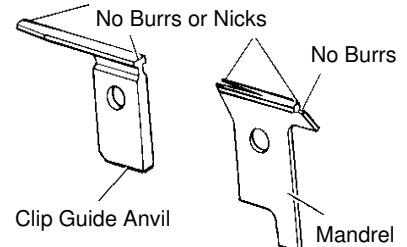

- 5 Before replacing side cover, clean insulation strippings and/or metal chips from internal mechanism of tool using air jet.



Protect eyes with safety glasses while using air jet to clean tool.

Figure 28

8. MAINTENANCE AND ADJUSTMENTS

8.1. Troubleshooting

TERMI-POINT air tools are thoroughly tested before they are shipped and should be in good operating condition when received by the customer. When a tool does not function properly or requires adjustment, refer to the following troubleshooting chart in and subsequent paragraphs to locate and correct troubles and/or to perform required adjustments.

Assembly drawings and parts lists are included for parts identification. Replacement parts and spare parts can be purchased from TE. If problems occur that cannot be corrected with the aid of the troubleshooting chart, contact your local TE Representative.

<b>TROUBLESHOOTING CHART</b>		
<b>SYMPTOM</b>	<b>CAUSE</b>	<b>POSSIBLE REMEDY</b>
1. Clip does not feed onto mandrel.	<ul style="list-style-type: none"> <li>(a) Clips distorted or not loaded properly.</li> <li>(b) Clip particles binding rear catch (Item 34, Figure 32).</li> <li>(c) Worn or broken push rod (Item 79, Figure 32).</li> <li>(d) Damaged clip jammed against rear of clip guide anvil (Item 24, Figure 32).</li> <li>(e) Worn or broken catch springs (Item 14, Figure 32).</li> <li>(f) Incorrect hold-down adjustment</li> </ul>	<ul style="list-style-type: none"> <li>(a) Unload tool (paragraph 6.7) and reload tool (paragraph 6.4).</li> <li>(b) Clean tool, using air jet through tool openings near rear catch (Figure 23).</li> <li>(c) Replace push rod (paragraph 8.5).</li> <li>(d) Unload tool (paragraph 6.7) break off and discard damaged clips, and then reload tool (paragraph 6.4).</li> <li>(e) Replace catch springs (paragraph 8.10).</li> <li>(f) Perform hold-down adjustment (paragraph 8.7).</li> </ul>
2. Clip is mangled or distorted when applied to post.	<ul style="list-style-type: none"> <li>(a) Incorrect clip, wire, or mandrel.</li> <li>(b) Incorrect or damaged post.</li> <li>(c) Incorrect alignment of tool to post.</li> <li>(d) Worn or damaged push rod (Item 79, Figure 32).</li> <li>(e) Worn or damaged clip guide anvil (Item 24, Figure 32).</li> </ul>	<ul style="list-style-type: none"> <li>(a) Ensure that correct clip, wire, and mandrel combination is being used. Refer to Section 3.</li> <li>(b) Replace post with proper size post for clip and mandrel being used.</li> <li>(c) Refer to paragraph 6.6 for proper operating procedure.</li> <li>(d) Replace push rod (paragraph 8.5).</li> <li>(e) Replace clip guide anvil (paragraph 8.8).</li> </ul>
3. Wire is not stripped cleanly or completely.	<ul style="list-style-type: none"> <li>(a) Wire not bottomed in mandrel.</li> <li>(b) Incorrect clip, wire, or mandrel.</li> <li>(c) Incorrect hold-down adjustment.</li> <li>(d) Mandrel worn or damaged in wire stripping area.</li> <li>(e) Worn or damaged push rod.</li> </ul>	<ul style="list-style-type: none"> <li>(a) Refer to paragraph 6.6 for proper operating procedure.</li> <li>(b) Ensure that proper combination of clip, wire, and mandrel is being used. Refer to Section 3.</li> <li>(c) Perform hold-down adjustment (paragraph 8.7).</li> <li>(d) Install new mandrel (paragraph 6.1).</li> <li>(e) Replace push rod (paragraph 8.5).</li> </ul>

<b>TROUBLESHOOTING CHART (Continued)</b>		
<b>SYMPTOM</b>	<b>CAUSE</b>	<b>POSSIBLE REMEDY</b>
4. Insulation does not eject.	(a) Short cycling of tool. (b) Clogged insulation receiver.	(a) Hold trigger for one second for each cycle. Refer to paragraph 6.6 for proper operating procedure. (b) Remove insulation strippings from receiver (paragraph 7.2).
5. Nicked or cut conductor.	(a) Incorrect clip, wire, or mandrel. (b) Incorrect or damaged post. (c) Worn or broken mandrel. (d) Incorrect hold-down adjustment.	(a) Ensure that proper combination of clip, wire, and mandrel is being used. Refer to Section 3. (b) Use proper size post for clip and mandrel being used. Replace damaged post. (c) Replace mandrel. Refer to paragraph 6.1. (d) Perform hold-down adjustment (paragraph 8.7).
6. Tool operates sluggishly.	(a) Incorrect air line pressure. (b) Incorrect clip, wire or mandrel. (c) Incorrect hold-down adjustment. (d) Damaged pneumatic cylinder assembly.	(a) Adjust for correct air line pressure (paragraph 2.1). (b) Ensure that proper clip, wire, and mandrel combination is being used. (e) Perform hold-down adjustment (paragraph 8.7). (f) Replace or repair pneumatic cylinder. See paragraph 8.4.
7. Clip has low tensile strength on post	(a) Incorrect clip application. (b) Incorrect clip, wire, or mandrel. (c) Incorrect or damaged post. (d) Worn or broken push rod.	(a) Carefully follow operating instructions (paragraph 6.6). (b) Ensure that proper clip, wire, and mandrel combination is being used. (See Section 3 ) (c) Use proper size post for clip and mandrel being used. (d) Replace push rod (paragraph 8.5).
8. Tool feeds two or more clips when cycled.	(a) Worn or broken front catch. (b) Fatigued or broken front catch spring.	(a) Replace front catch (paragraph 8.11). (b) Replace spring (paragraph 8.10).

## 8.2. General Disassembly Procedure

The following steps are common to most of the tool maintenance procedures given in the paragraphs to follow. Perform the following steps, as specified in each maintenance procedure, to prepare the tool for repair and/or part replacement:

1. Unload clips from tool (Paragraph 6.7).
2. Remove mandrel (Paragraph 6.2).
3. Remove “E” ring (Item 72), and slide “O” ring (Item 63) and cover plate (Item 69) down over tubing. See Figure 32.
4. Remove three screws (Items 85 and 74) from side cover and remove side cover (Item 4). Also, to prevent parts from falling out of tool and being lost, remove clip positioner (Item 44) with spring (Item 43) and remove spring (Item 42) from right post pickup (Item 86). See Figure 32.
5. Refer to applicable maintenance procedure for additional instructions.

## 8.3. General Reassembly Procedure

1. Assemble clip positioner (Item 44) in position and insert spring (Item 43, 1-1/4 in. long) into hole in clip positioner. Also, place spring (Item 42, 5/16 in. long) into hole in right post pickup (Item 85). See figure 32.
2. Ensure that pin (Item 116) (installed in side cover) fits into spring in clip positioner and that spring in right post pickup fits into hole in side cover. See Figure 32.
3. Install and tighten three screws (Items 85 and 74). The shorter screw (Item 74, 3/8 in. long) goes into hole near reel bracket, and the longer screw (Item 85, 5/8 in. long) go into the other two holes. After tightening screws, ensure that post pickups and clip positioner dial operate properly.
4. Bottom cover plate (Item 69) against tool handle, position “O” ring (Item 63) against cover plate, and install “E” ring (Item 72) in slot in handle. See Figure 32.
5. Install mandrel (Paragraph 6.1).
6. Load clips into tool (Paragraph 6.4).

## 8.4. Pneumatic Assembly - Disassembly and Reassembly

1. Perform all steps given in general disassembly procedure (Paragraph 8.2)
2. Remove four screws (Item 85) holding top cover (Item 51) to tool. Slide front of top cover to right from under pin (Item 39) in lever linkage (Item 38) to release top cover assembly from tool. See Figure 32.
3. Lift right post pickup (Item 86) from its pin (Item 98) and lay it aside. (This will keep this part from swinging or falling out of tool while repairs are being made.)
4. Lift push rod (Item 79) from its pin (installed through shaft of air cylinder) and remove push rod.
5. Remove screw (Item 67) to release air block (Item 7) from tool.
6. Remove two pipe-to-hose fittings (Item 113) and disconnect air hose (Item 129) from air block. Do not lose “O” ring (Item 10) on top opening of air block. Air block assembly can now be repaired or replaced, as required. Cartridge valve (Item 8) can easily be pulled out of the air block and replaced, if necessary.
7. For repair or replacement of air cylinder subassembly (Item 108), remove end cap (Item 109) to release end cover (Item 60) and air cylinder cover (Item 64) and remove these items. Use care not to lose “O” rings (Items 63 and 59). Remove screw (Item 85) and stop (Item 50) to release shaft of air cylinder, and then unscrew air cylinder subassembly from tool. Tilt rear of air cylinder up to allow drive pin in shaft of air cylinder to clear tool and remove air cylinder subassembly from tool.
8. To reassemble pneumatic assembly, perform steps (2) through (7) previously in reverse order. Be sure that drive pin in air cylinder shaft is positioned in slot in top of tool before screwing air cylinder into tool. After screwing air cylinder subassembly into position, use a screwdriver against the drive shaft pin (through slot in top of tool) to carefully force air cylinder shaft out far enough to install stop (Item 50). Use care to ensure that “O” rings (Items 59, 63, and 10) are properly assembled. Otherwise, tool will have excessive air leakage during operation. Also, ensure that tubing (Item 112) and air hose (Item 129) are properly assembled and that pipe-to-hose fittings are tight.

**NOTE**

*Complete step 9 before connecting tool to factory air.*



9. Refer to Paragraph 8.3 and follow general reassembly procedure.

**8.5. Push Rod Replacement**

1. Disconnect tool from factory air.
2. Remove four screws (Item 85) holding top cover (Item 51) to tool. Slide front of top cover to right from under pin (Item 39) in lever linkage (Item 38) to release top cover assembly from tool. See Figure 32.
3. Use small screwdriver or scribe to pry up rear of push rod (Item 79) from its drive pin and remove push rod. If necessary, saddle spring (Item 83) can now be replaced or removed for use on replacement push rod.
4. Ensure that correct saddle spring is mounted on replacement push rod and replace push rod on drive pin in tool.
5. Replace top cover assembly and tighten the four holding screws. Check wire funnel operation before connecting tool to factory air supply.
6. Check operation of tool to determine if hold-down adjustment is required (Paragraph 8.7).

**8.6. Clearing Jammed Tool**

When clips jam on rear area of clip guide anvil, push rod may be worn or broken, insulation strippings or clip particles may be jamming tool mechanism, or operator may be failing to hold trigger depressed for required one-second cycle time. Regardless of cause, tool should be disassembled in order to check and replace worn or broken parts, where necessary, and to clean clip and insulation particles from tool. Proceed as follows:

1. Disconnect tool from factory air supply.
2. Perform steps (2) through (4) of general disassembly procedure (Paragraph 8.2).

**NOTE**

*With mandrel removed, replace but do not tighten mandrel holding screw (Item 27).*



3. Perform steps (2) through (4) of pneumatic disassembly procedure (Paragraph 8.4).
4. Remove clip guide anvil holding screw (Item 117) and carefully lift clip guide anvil out of tool.
5. Carefully remove jammed clips from clip guide anvil. See Figure 29.
6. Inspect clip guide anvil and mandrel to be certain they have not been damaged by removal of jammed clips. Replace damaged parts, as required.
7. Check for worn or damaged push rod (Item 79) and/or saddle spring (Item 83). If worn or broken, push rod and/or saddle spring must be replaced (Paragraph 8.5).
8. Use an air jet to clean clip and insulation particles from tool.

**DANGER**

*Be sure to use eye protection, as required by safety regulations, when using air jet for tool cleaning.*



9. Carefully place clip guide anvil into tool, align hole with screw hole, and replace and tighten holding screw.
10. In reverse order, perform steps (2) through (4) of pneumatic assembly procedure (Paragraph 8.4) to reassemble top components of tool.
11. Refer to Paragraph 8.3 and perform general reassembly procedure.

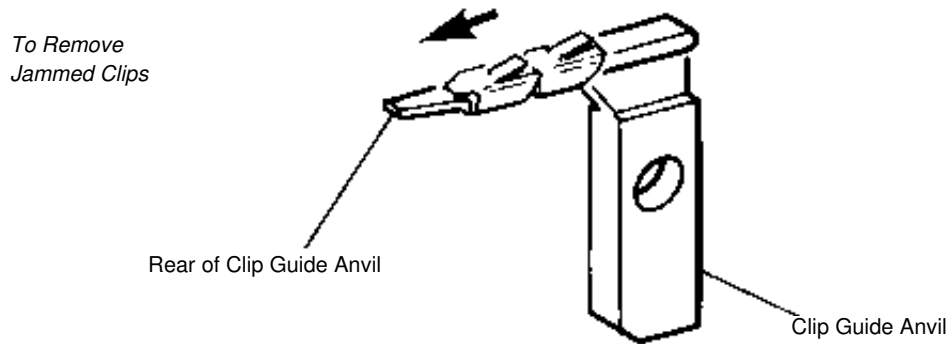

Figure 29

### 8.7. Hold-Down Adjustment

A socket setscrew (Item 77), with hex nut (Item 76), through hold-down (Item 75) is used to adjust the push rod hold-down clearance. See Figure 30. This adjustment controls the stripping action provided when the push rod forces the clip over the mandrel. Initially, the setscrew is adjusted to the point where the wire funnel, when it is forced up by the push rod, just clears the bottom surface of the top cover. When necessary, adjust hold-down setscrew as follows:

1. Loosen hex nut.
2. Adjust setscrew clockwise to reduce hold-down clearance or counterclockwise to increase clearance.

**NOTE** *Carefully check stripping action by operating tool, and readjust setscrew as necessary for proper wire stripping.*

3. Tighten hex nut to lock setscrew.

### 8.8. Clip Guide Anvil Replacement

1. Disconnect tool from factory air supply.
2. Perform all steps of general disassembly procedure (Paragraph 8.2).
3. Perform steps (2) through (4) of pneumatic disassembly procedure (Paragraph 8.4).

**NOTE** *With mandrel removed, replace but do not tighten mandrel holding screw.*

4. Remove clip guide anvil holding screw (Item 117) and carefully lift clip guide anvil out of tool.

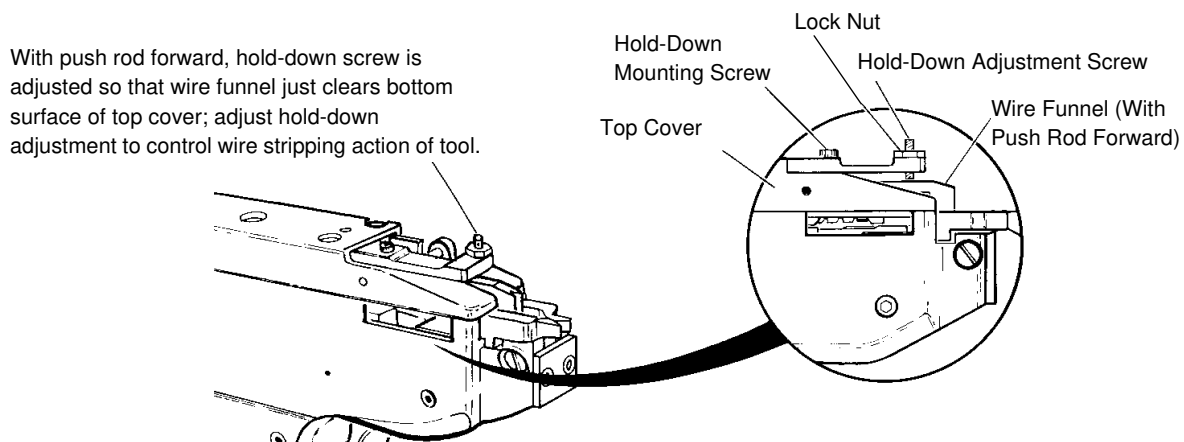

Figure 30

5. Carefully insert replacement clip guide anvil into tool, align hole with screw hole, and replace and tighten screw.



*Front and rear catches are pushed up against clip guide anvil by front and rear catch springs. After holding screw is started, hold tail of clip guide anvil down to keep part in alignment with mandrel.*

6. In reverse order, perform steps (2) through (4) of pneumatic assembly procedure (Paragraph 8.4) to reassemble top components of tool.

7. Refer to Paragraph 8.3 and perform general reassembly procedure.

#### 8.9. Post Pickups Replacement

1. Disconnect tool from factory air supply.

2. Remove mandrel (Paragraph 6.2).

3. Remove four screws holding top cover to tool. Slide front of top cover to right from under wire funnel lever pin to release top cover assembly from tool.

4. Use small screwdriver or scribe to pry up rear of push rod from its drive pin and remove push rod.

5. Remove each post pickup by lifting it from its pin; use care not to lose spring.

6. Replace each post pickup by inserting spring in hole and placing post pickup on its pin. Ensure correct spring placement.

7. Install push rod in position on its drive pin.

8. Replace top cover assembly and tighten the four holding screws. Check post pickup and wire funnel operation before connecting tool to factory air supply.

9. Install mandrel (Paragraph 6.1).

10. Connect tool to factory air supply and check tool operation.

#### 8.10. Catch Spring Replacement

1. Refer to clip guide anvil replacement procedure (Paragraph 8.8) and perform steps (1) through (4).

2. After clip guide anvil is removed, lift front and rear catches and remove springs.

3. Insert replacement springs in retaining holes and return front and rear catches to operating position.

4. Perform steps (5) through (7) of clip guide anvil replacement procedure (Paragraph 8.8) to reassemble tool.

#### 8.11. Front and Rear Catch Replacement

1. Refer to clip guide anvil replacement procedure (Paragraph 8.8) and perform steps (1) through (4).

2. After clip guide anvil is removed, lift front and rear catches and remove springs.

3. Remove both catches by carefully driving out pin (Item 40, Figure 32) through access hole in left side of tool.

4. Install replacement catches in position and drive pin through catches from right side of tool (pin flush with right side of tool body).

5. Insert springs in retaining holes and return front and rear catches to operating position.

6. Perform steps (5) through (7) of clip guide anvil replacement procedure (Paragraph 8.4) to reassemble tool.

#### 8.12. Clip Positioner Replacement

1. Perform all steps given in general disassembly procedure (Paragraph 8.2).

2. Insert replacement clip positioner and/or compression spring.

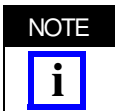

*If clip positioner dial must be replaced, it can be removed by removing shoulder screw (Item 99, Figure 32).*



3. Perform all steps of general reassembly procedure (Paragraph 8.3) to reassemble tool.

### 8.13. Wire Funnel Replacement

1. Disconnect tool from factory air supply.
2. Remove four screws holding top cover to tool. Slide front of top cover to right from under wire funnel lever pin to release top cover assembly from tool.
3. Drive pin (Item 41, Figure 32) out from right side of top cover to remove wire funnel; use care not to lose spring.
4. Insert replacement wire funnel in slot in top cover, ensure that spring is in position in retaining hole, and drive pin through wire funnel from left side of top cover (pin flush with left side of top cover).
5. Replace top cover assembly and tighten the four holding screws. Check wire funnel operation before connecting tool to factory air supply.
6. Check operation of tool to determine if hold down adjustment is required (Paragraph 8.7).

### 8.14. Air Line Filters and Lubricators

The use of air line filters and lubricators is recommended with TE pneumatic tooling. This equipment is not manufactured or sold by TE. The position of the recommended equipment is shown in Figure 31.

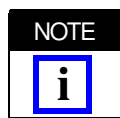

*Install air regulator between the filter and lubricator if shop air supply exceeds 655 kPa [95 psi].*



Figure 31

## 9. STORAGE

If the tool is not used, it must be stored by taking the following precautions:

- Store the tool indoors.
- Grease unpainted parts.
- Protect this tool from knocks or stresses.
- Protect the tool from high levels of humidity and from big temperature changes.
- Prevent the tool from coming into contact with corrosive substances.

## 10. DECOMMISSIONING

In compliance with the regulations in force in the country where the tool is used, the user must make sure that waste produced during operation is correctly disposed of. Disposal of lubricants and parts removed must be carried out in compliance with the standards in force in the country where the tool is used.

## 11. REPLACEMENT AND REPAIR

Customer-replaceable parts are listed in Figures 32 and 33. Parts other than those listed should be replaced by TE to ensure quality and reliability. Order replacement parts through your local TE Representative, or call 1-800-526-5142, or send a facsimile of your purchase order to 717-986-7605, or write to:

CUSTOMER SERVICE (038-035)  
 TYCO ELECTRONICS CORPORATION  
 PO BOX 3608  
 HARRISBURG PA 17105-3608

For customer repair service, call 1-800-526-5136.

## 12. REVISION SUMMARY

- Updated document to meet CE standards and current TE format and standards.



Parts List for Figure 32 - Pneumatic Tool Assembly 59865-1, -2, -3, and -7 (Cont'd)

ITEM NUMBER	PART NUMBER	QUANTITY	PART NAME/DESCRIPTION
1	311053-1	1	Main Frame (Tool No. 59865-1)(.022" x .036")
2	311053-2	1	Main Frame (Tool No. 59865-2 & -7)(.031" x .062")
3	311053-3	1	Main Frame (Tool No. 59865-3)(.031" x .093")
4	311054-1	1	Cover, Side (Tool No. 59865-1)(.022" x .036")
5	311054-2	1	Cover, Side (Tool No. 59865-2 & -7)(.031" x .062")
6	311054-3	1	Cover, Side (Tool No. 59865-3)(.031" x .093")
7	311062-1	1	Block, Air
8	20498-1	1	Valve, Cartridge
9	25575-2	1	Actuator, Pushbutton
10	3-21086-9	1	"O" Ring (.125" I.D.)
11	311367-1	1	L e v e r
12	1-21919-2	1	Pin, Dowel (3/32 Dia. x .500" Lg.)
13	—	—	Deleted
14	5-22278-8	2	Spring, Compression
15	59998-1	‡	Mandrel (.022" x .036")(for wire size AWG 28)
16	59998-2	‡	Mandrel (.022" x .036")(for wire size AWG 30)
17	59998-3	‡	Mandrel (.022" x .036")(for wire size AWG 32)
18	311078-1	‡	Mandrel (.031" x .062")(for wire size AWG 22)
19	311078-2	‡	Mandrel (.031" x .062")(for wire size AWG 24)
20	311078-3	‡	Mandrel (.031" x .062")(for wire size AWG 26)
21	311078-4	‡	Mandrel (.031" x .062")(for wire size AWG 28)
22	311079-1	‡	Mandrel (.031" x .093")(for wire size AWG 20)
23	311079-2	‡	Mandrel (.031" x .093")(for wire size AWG 24)
24	311082-1	1	Guide, Anvil Clip (Tool No. 59865-1)(.022" x .036")
25	311083-1	1	Guide, Anvil Clip (Tool No. 59865-2)(.031" x .062")
26	311083-2	1	Guide, Anvil Clip (Tool No. 59865-3)(.031" x .093")
27	22353-3	1	Screw, Shoulder, Slot Hd. (4-40)
28	311063-1	1	Catch, Front (Tool No. 59865-1)(.022" x .036")
29	311064-1	1	Catch, Front (Tool No. 59865-2 & -7)(.031" x .062")
30	311065-1	1	Catch, Front (Tool No. 59865-3)(.031" x .093")
31	311061-1	1	Funnel, Wire (Tool No. 59865-1)(.022" x .036")
32	311061-2	1	Funnel, Wire (Tool No. 59865-2 & -7)(.031" x .062")
33	311061-3	1	Funnel, Wire (Tool No. 59865-3)(.031" x .093")
34	311066-1	1	Catch, Rear (Tool No. 59865-1)(.022" x .036")
35	311067-1	1	Catch, Rear (Tool No. 59865-2 & -7)(.031" x .062")
36	311068-1	1	Catch, Rear (Tool No. 59865-3)(.031" x .093")
37	21028-5	1	Pin, Slotted (1/16" Dia. x .44" Lg.)
38	311368-1	1	Linkage, Lever
39	3-21028-5	1	Pin, Slotted (3/32" Dia. x .44" Lg.)
40	21919-5	1	Pin, Dowel (1/16" Dia. x .50" Lg.)
41	21028-6	1	Pin, Slotted (1/16" Dia. x .50" Lg.)
42	22278-2	3	Spring, Compression
43	6-22278-4	1	Spring, Compression
44	311074-1	1	Clip Positioner (Tool No. 59865-1)(.022" x .036")(3 Pos.)
45	311074-2	1	Clip Positioner (Tool No. 59865-2 & -7)(.031" x .062")(3 Pos.)
46	311074-3	1	Clip Positioner (Tool No. 59865-3)(.031" x .093")(3 Pos.)
47	—	—	Deleted
48	—	—	Deleted
49	—	—	Deleted

‡Sold separately; dependent on wire size.

Parts List for Figure 32 - Pneumatic Tool Assembly 59865-1, -2, -3, and -7 (Cont'd)

ITEM NUMBER	PART NUMBER	QUANTITY	PART NAME/DESCRIPTION
50	311528-1	1	Stop
51	311055-1	1	Cover, Top (Tool No. 59865-1)(.022" x .036")
52	311055-2	1	Cover, Top (Tool No. 59865-2)(.031" x .062")
53	311055-3	1	Cover, Top (Tool No. 59865-3)(.031" x .093")
54	--	--	Deleted
55	--	--	Deleted
56	--	--	Deleted
57	--	--	Deleted
58	--	--	Deleted
59	5-21084-0	1	"O" Ring (.500" I.D.)
60	311157-1	1	End Cover
61	--	--	Deleted
62	--	--	Deleted
63	4-21086-5	2	"O" Ring (.375" I.D.)
64	311081-1	1	Cover, Air Cylinder (Tool No. 59865-1)
65	311532-1	1	Cover, Air Cylinder (Tool No. 59865-2, -3, & -7)
66	--	--	Deleted
67	1-21003-3	1	Screw, F.H. Socket Cap (4-40)
68	--	--	Deleted
69	241037	1	Cover, Plate
70	--	--	Deleted
71	--	--	Deleted
72	2-21046-0	1	"E" Ring
73	--	--	Deleted
74	1-21000-4	2	Screw, Socket Hd., Cap (4-40 UNC-3A x .38" Lg.)
75	311377-1	1	Hold Down
76	21018-4	1	Nut, Hex (4-40 UNC-2B)
77	2-21006-3	1	Setscrew, Socket Hd. (4-40 UNC-3A x .38" Lg.)
78	311529-1	1	Plate, Nut
79	311056-1	1	Rod, Push (Tool No. 59865-1)(.022" x .036")
80	311057-1	1	Rod, Push (Tool No. 59865-2)(.031" x .062")
81	311058-1	1	Rod, Push (Tool No. 59865-3)(.031" x .093")
82	312382-1	1	Spring, Saddle (Tool No. 59865-1)(.022" x .036")
83	311071-1	1	Spring, Saddle (Tool No. 59865-2 & -7)(.031" x .062")
84	311072-1	1	Spring, Saddle (Tool No. 59865-3)(.031" x .093")
85	1-21000-6	7	Screw, Socket Hd. Cap (4-40 UNC-3A x .62" Lg.)
86	311091-1	1	Post Pickup, Right (Tool No. 59865-1)(.022" x .036")
87	312690-1	1	Post Pickup, Right (Tool No. 59865-2 & -7)(.031" x .062")
88	311091-3	1	Post Pickup, Right (Tool No. 59865-3)(.031" x .093")
89	311370-1	1	Guide Plate, Right (Tool No. 59865-1)(.022" x .036")
90	311370-2	1	Guide Plate, Right (Tool No. 59865-2 & -7)(.031" x .062")
91	311370-3	1	Guide Plate, Right (Tool No. 59865-3)(.031" x .093")
92	311371-1	1	Guide Plate, Left (Tool No. 59865-1)(.022" x .036")
93	311371-2	1	Guide Plate, Left (Tool No. 59865-2 & -7)(.031" x .062")
94	311371-3	1	Guide Plate, Left (Tool No. 59865-3)(.031" x .093")
95	311087-1	1	Post Pickup, Left (Tool No. 59865-1)(.022" x .036")
96	312691-1	1	Post Pickup, Left (Tool No. 59865-2 & -7)(.031" x .062")
97	312297-2	1	Post Pickup, Left (Tool No. 59865-3)(.031" x .093")
98	21919-9	2	Pin, Dowel (3/32" Dia. x .25" Lg.)

## Parts List for Figure 32 - Pneumatic Tool Assembly 59865-1, -2, -3, and -7 (End)

ITEM NUMBER	PART NUMBER	QUANTITY	PART NAME/DESCRIPTION
99	311369-1	1	Screw, Shoulder, Special
100	311372-1	1	Dial, Positioner (Tool No. 59865-1, -2, -3, & -7)(3 Pos.)
101	--	--	Deleted
102	--	--	Deleted
103	--	--	Deleted
104	--	--	Deleted
105	--	--	Deleted
106	25625-2	1	Plate, Identification
107	--	--	Deleted
108	311533-1	1	Air Cylinder Subassy
109	265327-1	1	Cap, End
110	--	--	Deleted
111	--	--	Deleted
112	22620-1	6"	Tubing, Polyethylene
113	22369-5	1	Coupling, Hose, Male
114	21003-9	4	Screw, F.H. Socket Cap (2-56 x .19" Lg.)
115	312135-1	1	Plate, Wear
116	21028-1	1	Pin, Slotted (1/16" Dia. x .19" Lg.)
117	22353-2	1	Screw, Shoulder, Slot Hd. (4-40)
118	312322-1	1	Knockout (Tool No. 59865-1)
119	--	--	Deleted
120	4-23147-6	1	Spring (Tool No. 59865-1)
121	21080-7	2	Setscrew (Tool No. 59865-1)(4-40 x .125" Lg.)
122	312321-1	1	Cap (Tool No. 59865-1)
123	--	--	Deleted
124	312376-1	1	Tooling Foot
125	312375-1	1	Tooling Foot (Tool No. 59865-1)
126	312504-1	1	Guide, Actuator
127	312503-1	1	Actuator
128	312505-1	1	Tooling Foot (Tool No. 59865-2 & -7)
129	312622-1	1	Subassy, Air Tube
130	311083-3	1	Guide, Anvil Clip (Tool No. 59865-7)(.031" x .062")
131	311057-2	1	Rod, Push (Tool No. 59865-7)(.031" x .062")

Pneumatic Tool Assembly 59865-1, -2, -3, and -7

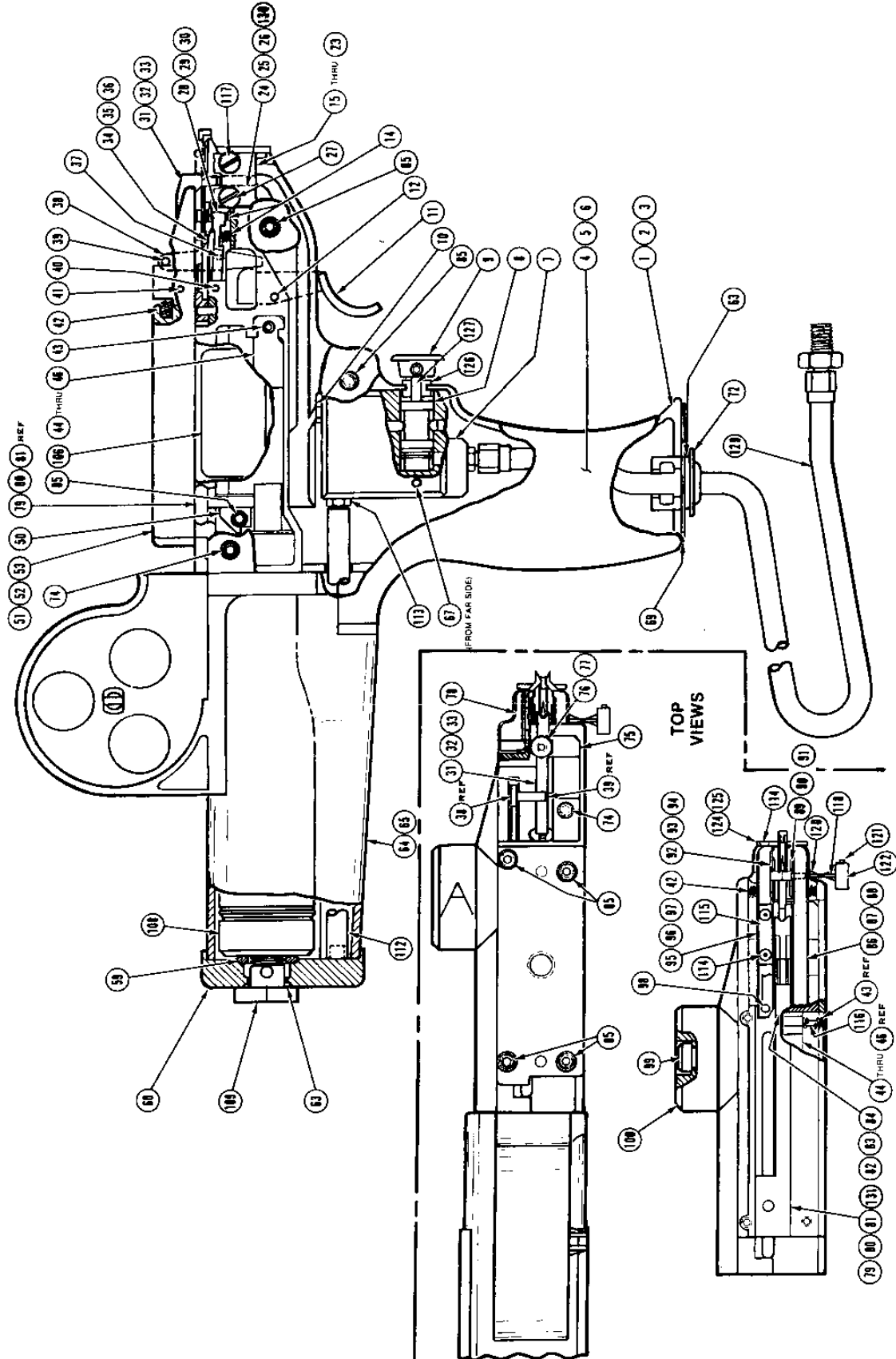

Figure 32

## Parts List for Figure 33 - Pneumatic Tool Assembly 59928-1, -2, -3, and -7 (Cont'd)

ITEM NUMBER	PART NUMBER	QUANTITY	PART NAME/DESCRIPTION
1	311053-1	1	Main Frame (Tool No. 59928-1)(.022" x .036")
2	311053-2	1	Main Frame (Tool No. 59928-2 & -7)(.031" x .062")
3	311053-3	1	Main Frame (Tool No. 59928-3)(.031" x .093")
4	311054-4	1	Cover, Side (Tool No. 59928-1)(.022" x .036")
5	311054-5	1	Cover, Side (Tool No. 59928-2 & -7)(.031" x .062")
6	311054-6	1	Cover, Side (Tool No. 59928-3)(.031" x .093")
7	311062-1	1	Block, Air
8	20498-1	1	Valve, Cartridge
9	25575-2	1	Actuator, Pushbutton
10	1-21000-6	7	Screw, Socket Hd. Cap (4-40 x .62" Lg.)
11	3-21086-9	1	"O" Ring (.125" I.D.)
12	311928-1	1	Pull Lever
13	1-24921-4	1	Screw, But. Hd. (8-32 x .31" Lg.)
14	311367-2	1	Lever
15	1-21919-2	1	Pin, Dowel (3/32 Dia. x .50" Lg.)
16	5-22278-8	2	Spring, Compression
17	59998-1	‡	Mandrel (.022" x .036")(for wire size AWG 28)
18	59998-2	‡	Mandrel (.022" x .036")(for wire size AWG 30)
19	59998-3	‡	Mandrel (.022" x .036")(for wire size AWG 32)
20	311078-1	‡	Mandrel (.031" x .062")(for wire size AWG 22)
21	311078-2	‡	Mandrel (.031" x .062")(for wire size AWG 24)
22	311078-3	‡	Mandrel (.031" x .062")(for wire size AWG 26)
23	311078-4	‡	Mandrel (.031" x .062")(for wire size AWG 28)
24	311079-1	‡	Mandrel (.031" x .093")(for wire size AWG 20)
25	311079-2	‡	Mandrel (.031" x .093")(for wire size AWG 24)
26	311082-1	1	Guide, Anvil Clip (Tool No. 59928-1)(.022" x .036")
27	311083-1	1	Guide, Anvil Clip (Tool No. 59928-2)(.031" x .062")
28	311083-2	1	Guide, Anvil Clip (Tool No. 59928-3)(.031" x .093")
29	22353-3	1	Screw, Shoulder, Slot Hd. (4-40)
30	311063-1	1	Catch, Front (Tool No. 59928-1)(.022" x .036")
31	311064-1	1	Catch, Front (Tool No. 59928-2 & -7)(.031" x .062")
32	311065-1	1	Catch, Front (Tool No. 59928-3)(.031" x .093")
33	311929-1	1	Funnel, Wire (Tool No. 59928-1)(.022" x .036")
34	311061-2	1	Funnel, Wire (Tool No. 59928-2 & -7)(.031" x .062")
35	311061-3	1	Funnel, Wire (Tool No. 59928-3)(.031" x .093")
36	311066-1	1	Catch, Rear (Tool No. 59928-1)(.022" x .036")
37	311067-1	1	Catch, Rear (Tool No. 59928-2 & -7)(.031" x .062")
38	311068-1	1	Catch, Rear (Tool No. 59928-3)(.031" x .093")
39	21028-5	1	Pin, Slotted (1/16" Dia. x .44" Lg.)
40	311368-1	1	Linkage, Lever
41	3-21028-5	1	Pin, Slotted (3/32" Dia. x .44" Lg.)
42	21919-5	1	Pin, Dowel (1/16" Dia. x .50" Lg.)
43	21028-6	2	Pin, Slotted (1/16" Dia. x .50" Lg.)
44	22278-2	3	Spring, Compression
45	6-22278-4	1	Spring, Compression
46	311074-1	1	Clip Positioner (Tool No. 59928-1)(.022" x .036")(3 Pos.)
47	311074-2	1	Clip Positioner (Tool No. 59928-2 & -7)(.031" x .062")(3 Pos.)
48	311074-3	1	Clip Positioner (Tool No. 59928-3)(.031" x .093")(3 Pos.)
49	—	—	Deleted

‡Sold separately; dependent on wire size.

## Parts List for Figure 33 - Pneumatic Tool Assembly 59928-1, -2, -3, and -7 (Cont'd)

ITEM NUMBER	PART NUMBER	QUANTITY	PART NAME/DESCRIPTION
50	--	--	Deleted
51	--	--	Deleted
52	25625-2	1	Plate, Identification
53	311528-1	1	Stop
54	311055-1	1	Cover, Top (Tool No. 59928-1)(.022" x .036")
55	311055-2	1	Cover, Top (Tool No. 59928-2 & -7)(.031" x .062")
56	311055-3	1	Cover, Top (Tool No. 59928-3)(.031" x .093")
57	1-21000-4	2	Screw, Socket Hd. Cap (4-40 x .38" Lg.)
58	311533-1	1	Air Cylinder Subassy
59	5-21084-0	1	"O" Ring (.500" I.D.)
60	311157-1	1	End Cover
61	265327-1	1	Cap End
62	4-21086-5	2	"O" Ring (.375" I.D.)
63	22620-1	6"	Tubing, Polyethylene
64	311081-1	1	Cover, Air Cylinder (Tool No. 59928-1)
65	311532-1	1	Cover, Air Cylinder (Tool No. 59928-2, -3, & -7)
66	22369-5	1	Coupling, Hose, Male
67	1-21003-3	1	Screw, F.H. Socket Cap (4-40)
68	--	--	Deleted
69	241037	1	Cover, Plate
70	--	--	Deleted
71	--	--	Deleted
72	2-21046-0	1	"E" Ring
73	--	--	Deleted
74	19596-1	1	Air Cylinder
75	2-21002-0	2	Screw, But. Hd. (8-32 x .25" Lg.)
76	1-21068-4	2	Nut, Hex (5-40)
77	311377-1	1	Hold Down
78	21018-4	1	Nut, Hex (4-40)
79	2-21006-3	1	Setscrew, Socket Hd. (4-40 x .38" Lg.)
80	311529-1	1	Plate, Nut
81	311927-1	1	Bracket
82	311056-1	1	Rod, Push (Tool No. 59928-1)(.022" x .036")
83	311057-1	1	Rod, Push (Tool No. 59928-2)(.031" x .062")
84	311058-1	1	Rod, Push (Tool No. 59928-3)(.031" x .093")
85	312382-1	1	Spring, Saddle (Tool No. 59928-1)(.022" x .036")
86	311071-1	1	Spring, Saddle (Tool No. 59928-2 & -7)(.031" x .062")
87	311072-1	1	Spring, Saddle (Tool No. 59928-3)(.031" x .093")
88	311091-1	1	Post Pickup, Right (Tool No. 59928-1)(.022" x .036")
89	312690-1	1	Post Pickup, Right (Tool No. 59928-2 & -7)(.031" x .062")
90	311091-3	1	Post Pickup, Right (Tool No. 59928-3)(.031" x .093")
91	311370-1	1	Guide Plate, Right (Tool No. 59928-1)(.022" x .036")
92	311370-2	1	Guide Plate, Right (Tool No. 59928-2 & -7)(.031" x .062")
93	311370-3	1	Guide, Plate, Right (Tool No. 59928-3)(.031" x .093")
94	311371-1	1	Guide Plate, Left (Tool No. 59928-1)(.022" x .036")
95	311371-2	1	Guide Plate, Left (Tool No. 59928-2 & -7)(.031" x .062")
96	311371-3	1	Guide Plate, Left (Tool No. 59928-3)(.031" x .093")
97	311087-1	1	Post Pickup, Left (Tool No. 59928-1)(.022" x .036")
98	312691-1	1	Post Pickup, Left (Tool No. 59928-2 & -7)(.031" x .062")

## Parts List for Figure 33 - Pneumatic Tool Assembly 59928-1, -2, -3, and -7 (End)

ITEM NUMBER	PART NUMBER	QUANTITY	PART NAME/DESCRIPTION
99	312297-2	1	Post Pickup, Subassy
100	21919-9	2	Pin, Dowel (3/32" Dia. x .25" Lg.)
101	311369-1	1	Screw, Shoulder, Special
102	311372-1	1	Dial, Positioner (Tool No. 59928-1, -2, -3, & -7)(3 Pos.)
103	--	--	Deleted
104	21003-9	4	Screw, F.H. Socket Cap (2-56 x .19" Lg.)
105	312135-1	1	Plate, Wear
106	21028-1	1	Pin, Slotted (1/16" Dia. x .19" Lg.)
107	22353-2	1	Screw, Shoulder, Slot Hd. (4-40)
108	312322-1	1	Knockout (Tool No. 59928-1)
109	--	--	Deleted
110	312321-1	1	Cap (Tool No. 59928-1)
111	4-23147-6	1	Spring (Tool No. 59928-1 & -3)
112	21080-7	2	Setscrew (Tool No. 59928-1 & -3)(4-40 x .125" Lg.)
113	--	--	Deleted
114	312376-1	1	Tooling Foot (Tool No. 59928-1)
115	312375-1	1	Tooling Foot
116	312504-1	1	Guide, Actuator
117	312503-1	1	Actuator
118	312505-1	1	Tooling Foot (Tool No. 59928-2 & -7)
119	312622-1	2	Subassy, Air Tube
120	311057-2	1	Rod, Push (Tool No. 59928-7)(.031" x .062")
121	311083-3	1	Guide, Anvil Clip (Tool No. 59928-7)(.031" x .062")

Pneumatic Tool Assembly 59928-1, -2, -3, and -7

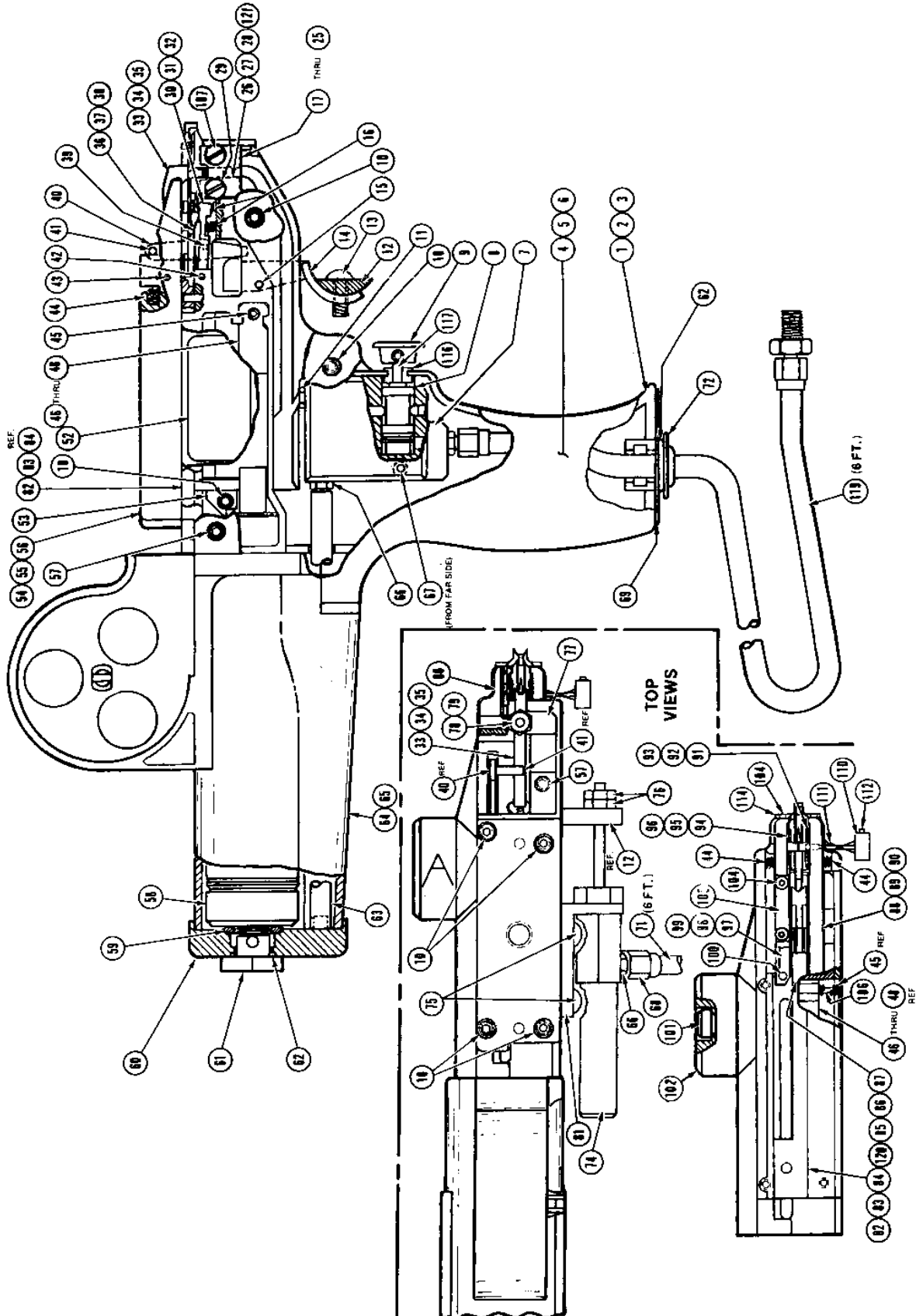

Figure 33