

Open Type Trimmer

Model 38



Features:

- 10 mm single turn
- Dust proof
- Carbon element
- Low TCR
- RoHS compliant



Model Styles Available

Top Adjust	38P
Side Adjust	38W

Electrical

Resistance Range	100 to 1,000,000 Ohms
Standard Resistance Tolerance	± 30%, (±20% and ±10% available)
Input Voltage, Maximum	200 Vdc
Power rating, Watts	Linear :0.15W, others : 0.07W, at 50°C
End Resistance, Maximum	2 ohms or 0.5% whichever is greater
Actual Electrical Travel	220° ±20°
Insulation Resistance, Minimum	100 Megohms
Resolution	Essentially infinite
Contact Resistance Variation	5% Max.
Temperature Coefficient of Resistance	±500 ppm/°C

Mechanical

Torque, Maximum	1.5 in - oz.
Wiper Position	Approx. 50%

General Note
TT Electronics reserves the right to make changes in product specification without notice or liability. All information is subject to TT Electronics' own data and is considered accurate at time of going to print.

© TT electronics plc

TT Electronics | BI Technologies
413 Rood RD, Suite 7
Calexico, CA 92231
Ph: + 1 (714) 447-2345
www.ttelectronics.com/bi-technologies

Issue B 04/2019 Page 1

Outline Drawings

Model 38P (Top Adjust)

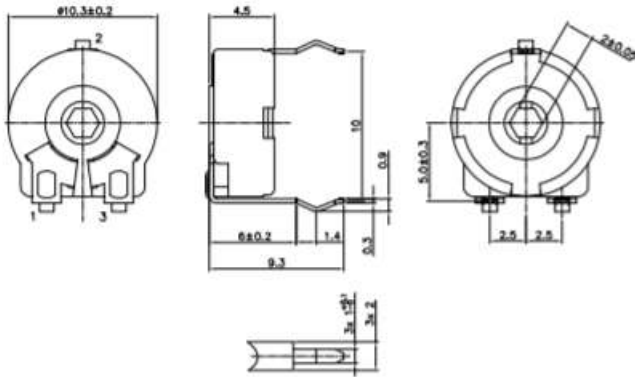

Model 38W (Side Adjust)

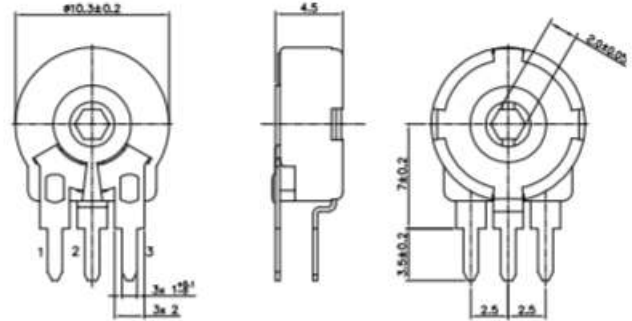

Circuit Diagram

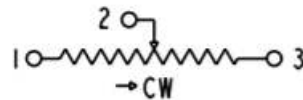

Standard Resistance Values, Ohms

100	500	1K	2K	5K	10K	20K	50K	100K	200K	500K	1MEG
-----	-----	----	----	----	-----	-----	-----	------	------	------	------

General Note

TT Electronics reserves the right to make changes in product specification without notice or liability. All information is subject to TT Electronics' own data and is considered accurate at time of going to print.