

SPECIFICATION CONTROL DRAWING

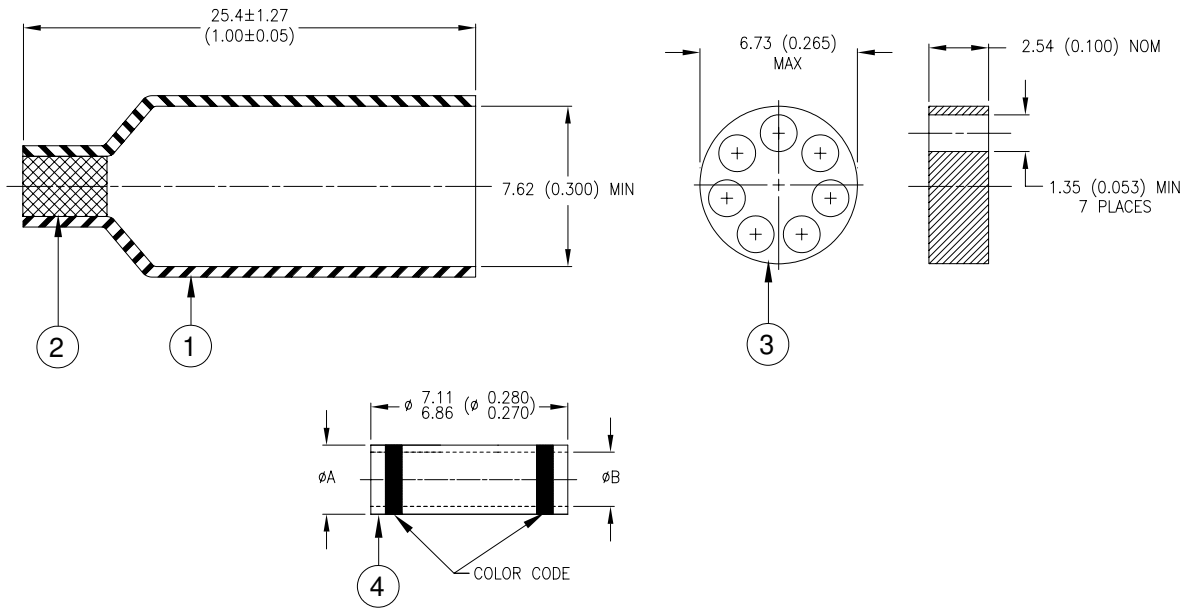

MATERIALS

1. INSULATION SLEEVE: Heat-shrinkable, transparent blue, radiation cross-linked modified polyvinylidene fluoride.
2. TOP SEAL: Low outgassing thermoplastic, color-blue.
3. MULTI-CONDUCTOR SEAL: Low outgassing thermoplastic, color-natural.
4. CRIMP FERRULE: Nickel-plated copper alloy. Color Code: see table.

BASE METAL: Copper Alloy 102 per ASTM B-75.

PLATING: Ductile Nickel SAE AMS-QQ-N-290.

Dimensions:

Product Name	øA	øB	Color Code	CMA Range
D-436-0151	2.67 (0.105)	1.75 (0.069)	Blue	779 - 2680
	2.56 (0.101)	1.65 (0.065)		
D-436-0153	3.89 (0.153)	2.59 (0.102)	Yellow	1900 - 6755
	3.73 (0.147)	2.46 (0.097)		

APPLICATION

1. These parts are designed to make an immersion resistant stub splice in wires having insulations rated for at least 135°C.
2. Wire Accomodation:

Jacket O.D.: 1.32 (0.052) max

D-436-0151		
Gauge (AWG)	CMA	Number
22	754	2 - 3
24	475	2 - 5
26	304	3 - 7

D-436-0153		
Gauge (AWG)	CMA	Number
22	754	3 - 7
24	475	4 - 7

3. Parts will meet performance requirements of MIL-S-81824/1.

tyco Electronics		Tyco Electronics Corporation 300 Constitution Drive, Menlo Park, CA. 94025, U.S.A.		<i>Raychem</i>		TITLE: STUB SPLICE SEALING SYSTEM, MULTI-WIRE, Ni-PLATED CRIMP	
Unless otherwise specified dimensions are in millimeters. [Inches dimensions are shown in brackets]				DOCUMENT NO.: D-436-0151/-0153			
TOLERANCES: 0.00 N/A 0.0 N/A 0 N/A		ANGLES: N/A ROUGHNESS IN MICRON		Tyco Electronics reserves the right to amend this drawing at any time. Users should evaluate the suitability of the product for their application.		REV.: A	
DATE: 11-Jan-06							
DCR NUMBER: D050545		REPLACES: ---		CAGE CODE : 06090		SCALE: ---	
SIZE: A		SHEET: 1 of 1					

© 2006 Tyco Electronics Corporation. All rights reserved.

If this document is printed it becomes uncontrolled. Check for the latest revision.