

# MAXIM

## +3V/+5V, Serial-Input, Voltage-Output, 14-Bit DACs

MAX5141-MAX5144

### General Description

The MAX5141-MAX5144 are serial-input, voltage-output, 14-bit digital-to-analog converters (DACs) in tiny  $\mu$ MAX packages, 50% smaller than comparable DACs in an 8-pin SO. They operate from low +3V (MAX5143/MAX5144) or +5V (MAX5141/MAX5142) single supplies. They provide 14-bit performance ( $\pm 1$ LSB INL and DNL) over temperature without any adjustments. The DAC output is unbuffered, resulting in a low supply current of 120 $\mu$ A and a low offset error of 2LSBs.

The DAC output range is 0V to  $V_{REF}$ . For bipolar operation, matched scaling resistors are provided in the MAX5142/MAX5144 for use with an external precision op amp (such as the MAX400), generating a  $\pm V_{REF}$  output swing.

A 16-bit serial word is used to load data into the DAC latch. The 25MHz, 3-wire serial interface is compatible with SPI™/QSPI™/MICROWIRE™, and can interface directly with optocouplers for applications requiring isolation. A power-on reset circuit clears the DAC output to code 0 (MAX5141/MAX5143) or code 8192 (MAX5142/MAX5144) when power is initially applied.

A logic low on  $\overline{CLR}$  asynchronously clears the DAC output to code 0 (MAX5141/MAX5143) or code 8192 (MAX5142/MAX5144), independent of the serial interface.

The MAX5141/MAX5143 are available in 8-pin  $\mu$ MAX packages and the MAX5142/MAX5144 are available in 10-pin  $\mu$ MAX packages.

### Applications

High-Resolution and Gain Adjustment  
Industrial Process Control  
Automated Test Equipment  
Data-Acquisition Systems

### Features

- ◆ Miniature (3mm x 5mm) 8-Pin  $\mu$ MAX Package
- ◆ Low 120 $\mu$ A Supply Current
- ◆ Fast 1 $\mu$ s Settling Time
- ◆ 25MHz SPI/QSPI/MICROWIRE-Compatible Serial Interface
- ◆  $V_{REF}$  Range Extends to  $V_{DD}$
- ◆ +5V (MAX5141/MAX5142) or +3V (MAX5143/MAX5144) Single-Supply Operation
- ◆ Full 14-Bit Performance Without Adjustments
- ◆ Unbuffered Voltage Output Directly Drives 60k $\Omega$  Loads
- ◆ Power-On Reset Circuit Clears DAC Output to Code 0 (MAX5141/MAX5143) or Code 8192 (MAX5142/MAX5144)
- ◆ Schmitt-Trigger Inputs for Direct Optocoupler Interface
- ◆ Asynchronous  $\overline{CLR}$

### Pin Configurations

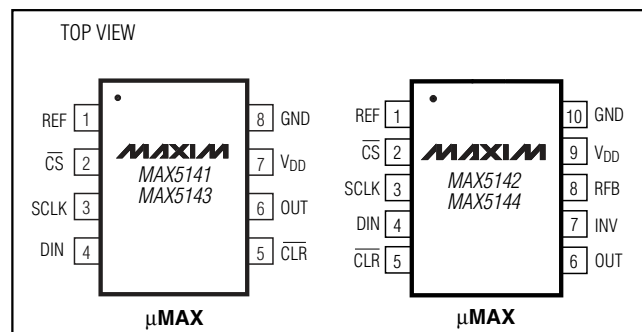

### Ordering Information

PART	TEMP. RANGE	PIN-PACKAGE	INL (LSB)	SUPPLY RANGE (V)	OUTPUT SWING
MAX5141EUA	-40°C to +85°C	8 $\mu$ MAX	$\pm 1$	5	Unipolar
MAX5142EUB	-40°C to +85°C	10 $\mu$ MAX	$\pm 1$	5	Bipolar
MAX5143EUA	-40°C to +85°C	8 $\mu$ MAX	$\pm 1$	3	Unipolar
MAX5144EUB	-40°C to +85°C	10 $\mu$ MAX	$\pm 1$	3	Bipolar

SPI and QSPI are trademarks of Motorola, Inc.  
MICROWIRE is a trademark of National Semiconductor Corp.

MAXIM

Maxim Integrated Products 1

For pricing, delivery, and ordering information, please contact Maxim/Dallas Direct! at 1-888-629-4642, or visit Maxim's website at [www.maxim-ic.com](http://www.maxim-ic.com).

# +3V/+5V, Serial-Input, Voltage-Output, 14-Bit DACs

## ABSOLUTE MAXIMUM RATINGS

V <sub>DD</sub> to GND	-0.3V to +6V
CS, SCLK, DIN, CLR to GND	-0.3V to +6V
REF to GND	-0.3V to (V <sub>DD</sub> + 0.3V)
OUT, INV to GND	-0.3V to V <sub>DD</sub>
RFB to INV	-6V to +6V
RFB to GND	-6V to +6V
Maximum Current into Any Pin	50mA
Continuous Power Dissipation (T <sub>A</sub> = +70°C)	
8-Pin $\mu$ MAX (derate 4.5mW/°C above +70°C)	362mW
10-Pin $\mu$ MAX (derate 5.6mW/°C above +70°C)	444mW

Operating Temperature Ranges	
MAX514_ EUA	-40°C to +85°C
MAX514_ EUB	-40°C to +85°C
Storage Temperature Range	-65°C to +150°C
Maximum Die Temperature	+150°C
Lead Temperature (soldering, 10s)	+300°C

Stresses beyond those listed under "Absolute Maximum Ratings" may cause permanent damage to the device. These are stress ratings only, and functional operation of the device at these or any other conditions beyond those indicated in the operational sections of the specifications is not implied. Exposure to absolute maximum rating conditions for extended periods may affect device reliability.

## ELECTRICAL CHARACTERISTICS

(V<sub>DD</sub> = +3V (MAX5143/MAX5144) or +5V (MAX5141/MAX5142), V<sub>REF</sub> = +2.5V, T<sub>A</sub> = T<sub>MIN</sub> to T<sub>MAX</sub>, C<sub>L</sub> = 10pF, GND = 0, R<sub>L</sub> =  $\infty$ , unless otherwise noted. Typical values are at T<sub>A</sub> = +25°C.)

PARAMETER	SYMBOL	CONDITIONS	MIN	TYP	MAX	UNITS
<b>STATIC PERFORMANCE—ANALOG SECTION</b>						
Resolution	N		14			Bits
Differential Nonlinearity	DNL	Guaranteed monotonic		$\pm 0.5$	$\pm 1$	LSB
Integral Nonlinearity	INL	MAX514_		$\pm 0.5$	$\pm 1$	LSB
Zero-Code Offset Error	ZSE				$\pm 2$	LSB
Zero-Code Tempco	ZSTC			$\pm 0.05$		ppm/°C
Gain Error (Note 1)					$\pm 10$	LSB
Gain-Error Tempco				$\pm 0.1$		ppm/°C
DAC Output Resistance	R <sub>OUT</sub>	(Note 2)		6.2		k $\Omega$
Bipolar Resistor Matching		R <sub>F</sub> B/R <sub>I</sub> NV		1		%
		Ratio error			$\pm 0.03$	
Bipolar Zero Offset Error					$\pm 20$	LSB
Bipolar Zero Tempco	BZSTC			$\pm 0.5$		ppm/°C
Power-Supply Rejection	PSR	+2.7V $\leq$ V <sub>DD</sub> $\leq$ +3.3V (MAX5143/MAX5144)			$\pm 1$	LSB
		+4.5V $\leq$ V <sub>DD</sub> $\leq$ +5.5V (MAX5141/MAX5142)			$\pm 1$	
Reference Input Range	V <sub>REF</sub>	(Note 3)	2.0		V <sub>DD</sub>	V
Reference Input Resistance (Note 4)	R <sub>REF</sub>	Unipolar mode	10			k $\Omega$
		Bipolar mode	6			
<b>DYNAMIC PERFORMANCE—ANALOG SECTION</b>						
Voltage-Output Slew Rate	SR	(Note 5)		15		V/ $\mu$ s
Output Settling Time		To $\pm 1/2$ LSB of FS		1		$\mu$ s
DAC Glitch Impulse		Major-carry transition		7		nV-s
Digital Feedthrough		Code = 0000 hex; $\overline{\text{CS}} = \text{V}_{\text{DD}}$ ; SCLK, DIN = 0V to V <sub>DD</sub> levels		0.2		nV-s

# +3V/+5V, Serial-Input, Voltage-Output, 14-Bit DACs

**MAX5141-MAX5144**

## ELECTRICAL CHARACTERISTICS (continued)

( $V_{DD} = +3V$  (MAX5143/MAX5144) or  $+5V$  (MAX5141/MAX5142),  $V_{REF} = +2.5V$ ,  $T_A = T_{MIN}$  to  $T_{MAX}$ ,  $C_L = 10pF$ ,  $GND = 0$ ,  $R_L = \infty$ , unless otherwise noted. Typical values are at  $T_A = +25^\circ C$ .)

PARAMETER	SYMBOL	CONDITIONS	MIN	TYP	MAX	UNITS
<b>DYNAMIC PERFORMANCE—REFERENCE SECTION</b>						
Reference -3dB Bandwidth	BW	Code = 3FFF hex		1		MHz
Reference Feedthrough		Code = 0000 hex, $V_{REF} = 1V_{P-P}$ at 100kHz		1		mV <sub>P-P</sub>
Signal-to-Noise Ratio	SNR			92		dB
Reference Input Capacitance	$C_{INREF}$	Code = 0000 hex		70		pF
		Code = 3FFF hex		170		
<b>STATIC PERFORMANCE—DIGITAL INPUTS</b>						
Input High Voltage	$V_{IH}$		2.4			V
Input Low Voltage	$V_{IL}$				0.8	V
Input Current	$I_{IN}$				$\pm 1$	$\mu A$
Input Capacitance	$C_{IN}$	(Note 6)		3	10	pF
Hysteresis Voltage	$V_H$			0.15		V
<b>POWER SUPPLY</b>						
Positive Supply Range (Note 7)	$V_{DD}$	MAX5143/MAX5144	2.7		3.6	V
		MAX5141/MAX5142	4.5		5.5	
Positive Supply Current	$I_{DD}$	All digital inputs at $V_{DD}$ or GND		0.12	0.20	mA
Power Dissipation	PD	All digital inputs at $V_{DD}$ or GND	MAX5143/MAX5144	0.36		mW
			MAX5141/MAX5142	0.60		

## TIMING CHARACTERISTICS

( $V_{DD} = +2.7V$  to  $+3.3V$  (MAX5143/MAX5144),  $V_{DD} = +4.5V$  to  $+5.5V$  (MAX5141/MAX5142),  $V_{REF} = +2.5V$ ,  $GND = 0$ , CMOS inputs,  $T_A = T_{MIN}$  to  $T_{MAX}$ , unless otherwise noted. Typical values are at  $T_A = +25^\circ C$ .) (Figure 1)

PARAMETER	SYMBOL	CONDITIONS	MIN	TYP	MAX	UNITS
SCLK Frequency	$f_{CLK}$				25	MHz
SCLK Pulse Width High	$t_{CH}$		20			ns
SCLK Pulse Width Low	$t_{CL}$		20			ns
$\overline{CS}$ Low to SCLK High Setup	$t_{CSS0}$		15			ns
$\overline{CS}$ High to SCLK High Setup	$t_{CSS1}$		15			ns
SCLK High to $\overline{CS}$ Low Hold	$t_{CSH0}$	(Note 6)	35			ns
SCLK High to $\overline{CS}$ High Hold	$t_{CSH1}$		20			ns
DIN to SCLK High Setup	$t_{DS}$		15			ns
DIN to SCLK High Hold	$t_{DH}$		0			ns
$\overline{CLR}$ Pulse Width Low	$t_{CLW}$		20			ns
$V_{DD}$ High to $\overline{CS}$ Low (Power-Up Delay)				20		$\mu s$

**Note 1:** Gain error tested at  $V_{REF} = +2.0V$ ,  $+2.5V$ , and  $+3.0V$  (MAX5143/MAX5144) or  $V_{REF} = +2.0V$ ,  $+2.5V$ ,  $+3.0V$ , and  $+5.0V$  (MAX5141/MAX5142).

**Note 2:**  $R_{OUT}$  tolerance is typically  $\pm 20\%$ .

**Note 3:** Min/max range guaranteed by gain-error test. Operation outside min/max limits will result in degraded performance.

**Note 4:** Reference input resistance is code dependent, minimum at 2155 hex in unipolar mode, 1155 hex in bipolar mode.

**Note 5:** Slew-rate value is measured from 10% to 90%.

**Note 6:** Guaranteed by design. Not production tested.

**Note 7:** Guaranteed by power-supply rejection test and *Timing Characteristics*.

# +3V/+5V, Serial-Input, Voltage-Output, 14-Bit DACs

## Typical Operating Characteristics

( $V_{DD} = +3V$  (MAX5143/MAX5144) or  $+5V$  (MAX5141/MAX5142),  $V_{REF} = +2.5V$ ,  $T_A = T_{MIN}$  to  $T_{MAX}$ ,  $GND = 0$ ,  $R_L = \infty$ , unless otherwise noted. Typical values are at  $T_A = +25^\circ C$ .)

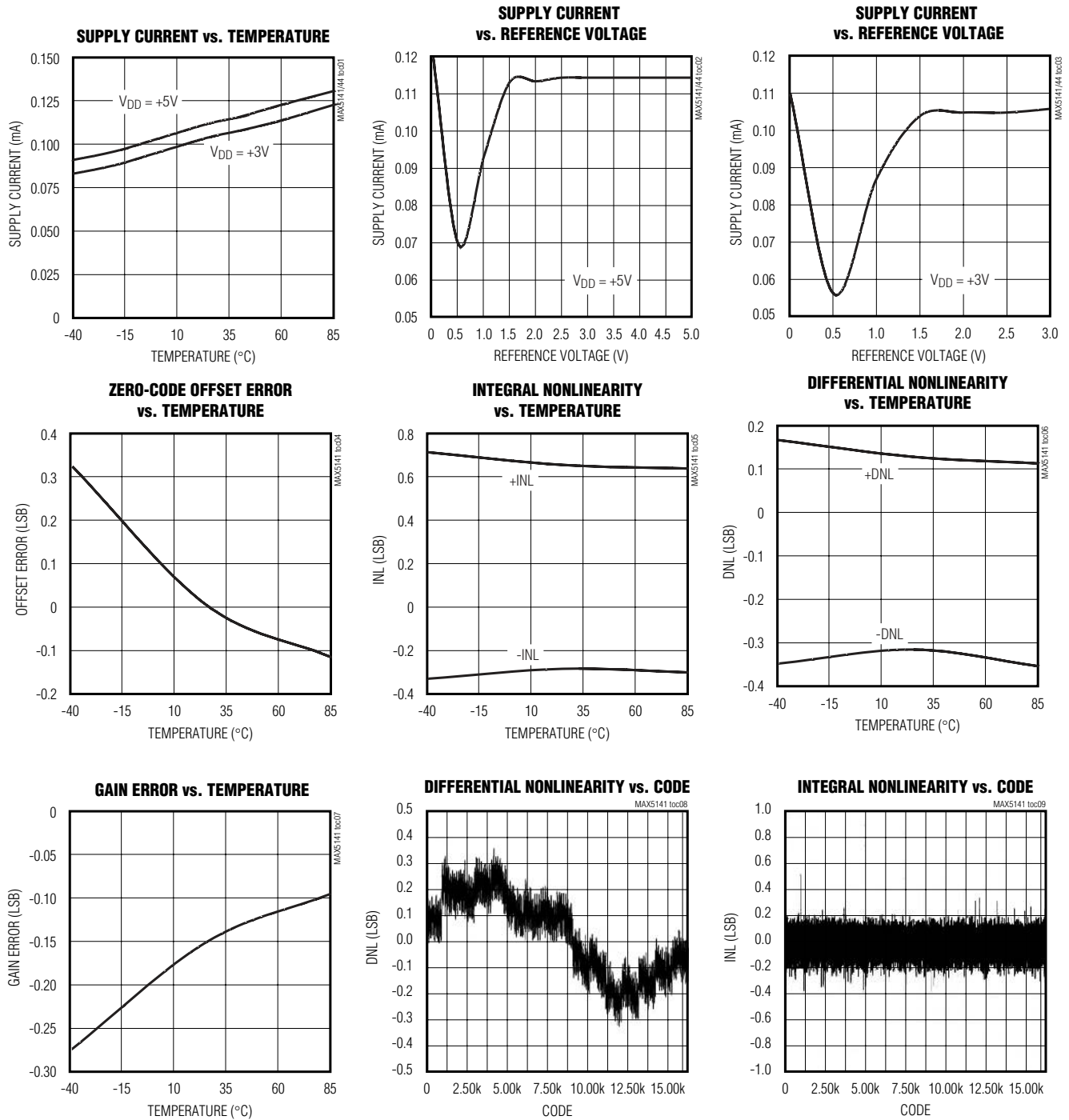

# +3V/+5V, Serial-Input, Voltage-Output, 14-Bit DACs

MAX5141-MAX5144

## Typical Operating Characteristics (continued)

( $V_{DD} = +3V$  (MAX5143/MAX5144) or  $+5V$  (MAX5141/MAX5142),  $V_{REF} = +2.5V$ ,  $T_A = T_{MIN}$  to  $T_{MAX}$ ,  $GND = 0$ ,  $R_L = \infty$ , unless otherwise noted. Typical values are at  $T_A = +25^\circ C$ .)

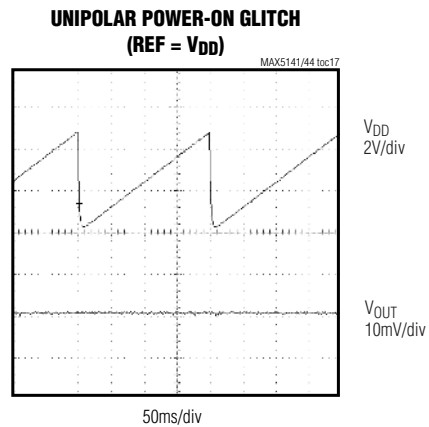
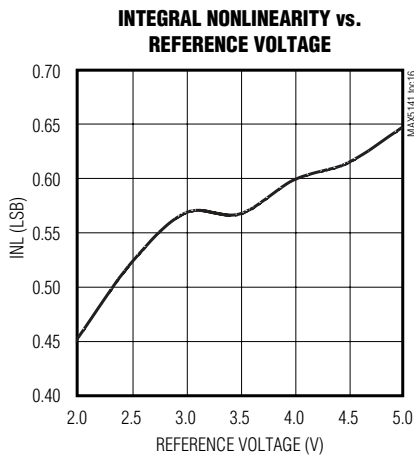
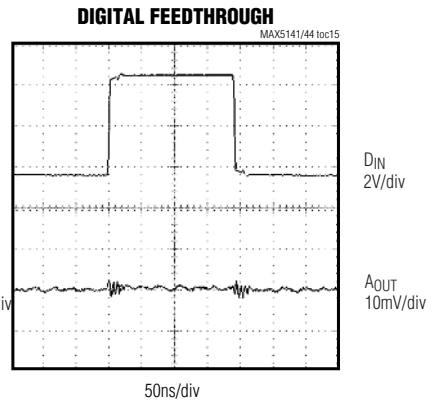
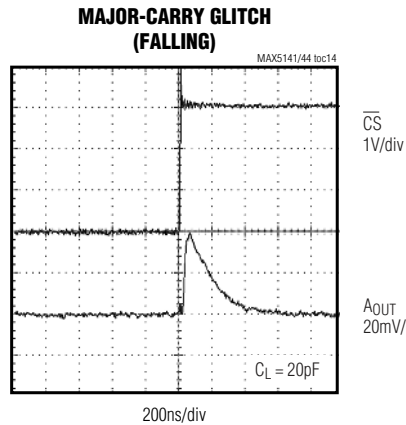
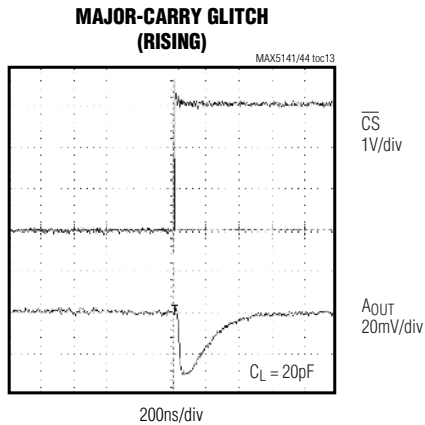
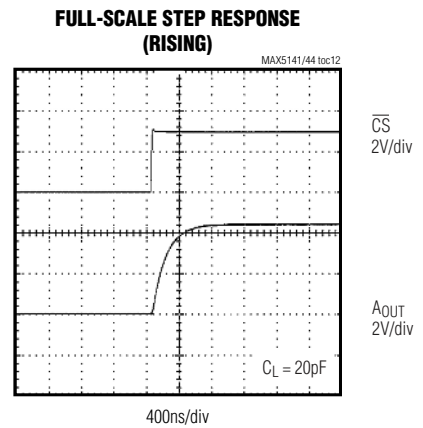
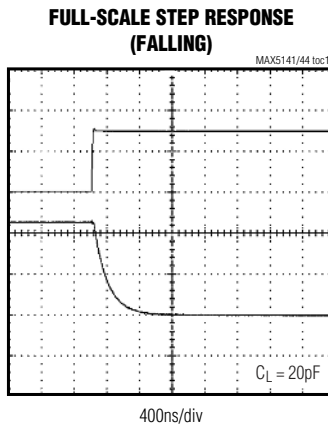
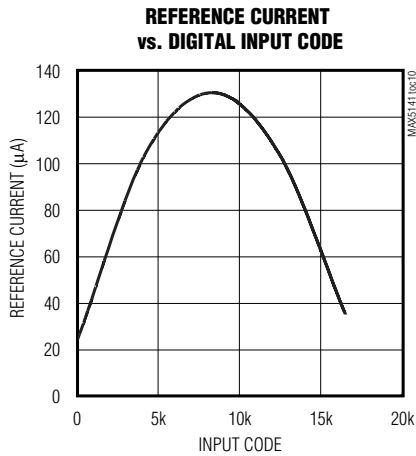

# +3V/+5V, Serial-Input, Voltage-Output, 14-Bit DACs

## Pin Descriptions

PIN		NAME	FUNCTION
MAX5141 MAX5143	MAX5142 MAX5144		
1	1	REF	Voltage Reference Input
2	2	$\overline{CS}$	Chip-Select Input
3	3	SCLK	Serial Clock Input. Duty cycle must be between 40% and 60%.
4	4	DIN	Serial Data Input
5	5	$\overline{CLR}$	Clear Input. Logic low asynchronously clears the DAC to code 0 (MAX5141/MAX5143) or code 8192 (MAX5142/MAX5144).
6	6	OUT	DAC Output Voltage
—	7	INV	Junction of Internal Scaling Resistors. Connect to external op amp's inverting input in bipolar mode.
—	8	RFB	Feedback Resistor. Connect to external op amp's output in bipolar mode.
7	9	V <sub>DD</sub>	Supply Voltage. Use +3V for MAX5143/MAX5144 and +5V for MAX5141/MAX5142.
8	10	GND	Ground

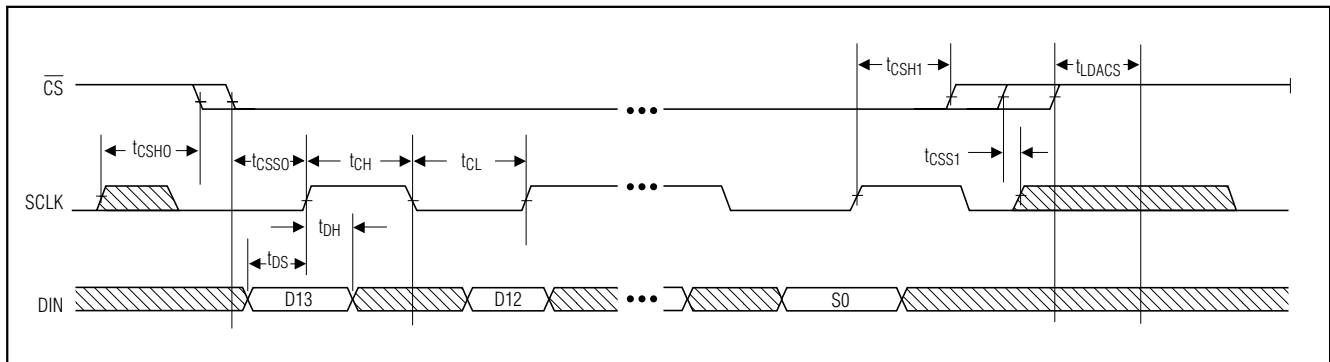

Figure 1. Timing Diagram

# +3V/+5V, Serial-Input, Voltage-Output, 14-Bit DACs

MAX5141-MAX5144

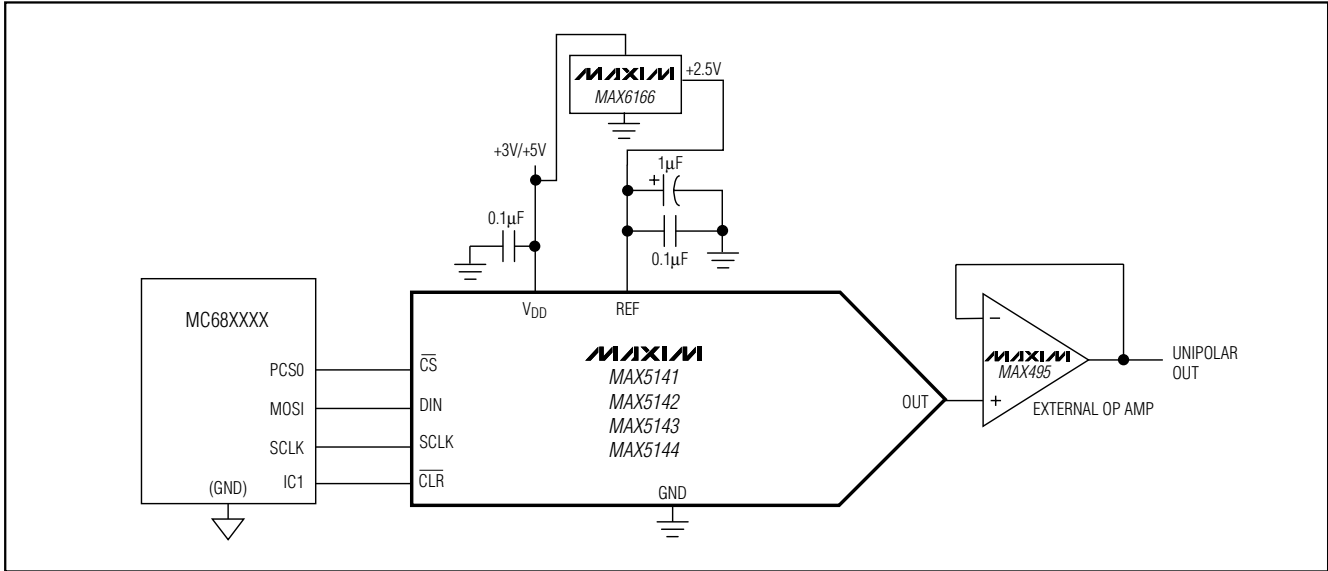

Figure 2a. Typical Operating Circuit—Unipolar Output

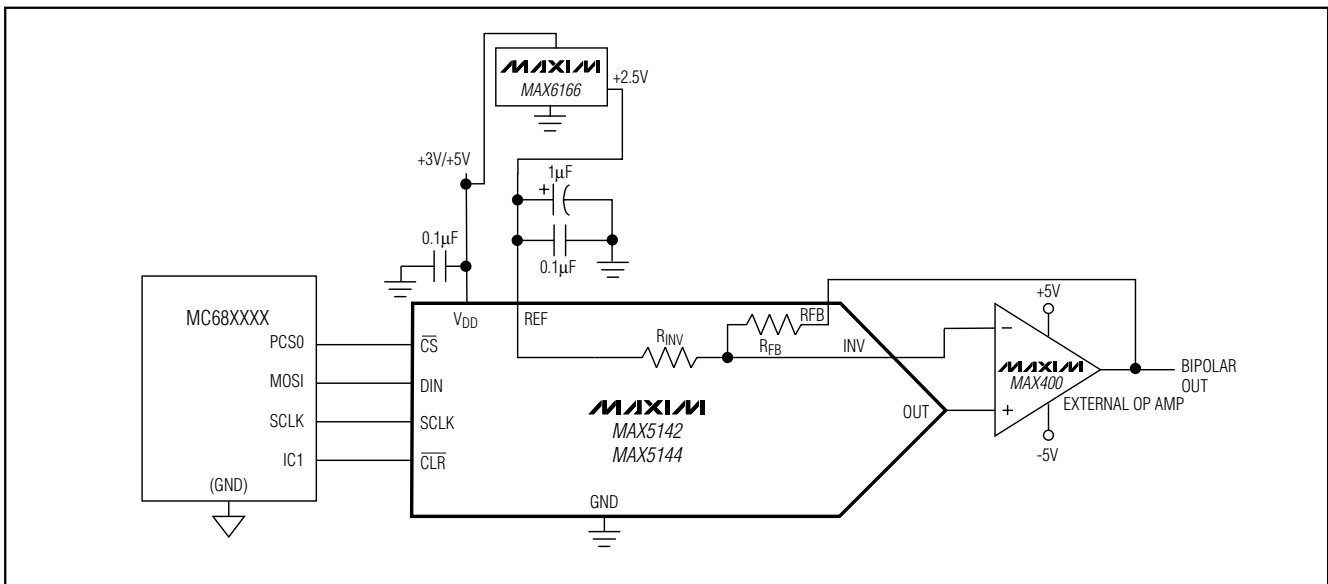

Figure 2b. Typical Operating Circuit—Bipolar Output

## Detailed Description

The MAX5141-MAX5144 voltage-output, 14-bit digital-to-analog converters (DACs) offer full 14-bit performance with less than 1LSB integral linearity error and less than 1LSB differential linearity error, thus ensuring monotonic performance. Serial data transfer minimizes the number of package pins required.

The MAX5141-MAX5144 are composed of two matched DAC sections, with a 10-bit inverted R-2R DAC forming the ten LSBs and the four MSBs derived from 15 identically matched resistors. This architecture allows the lowest glitch energy to be transferred to the DAC output on major-carry transitions. It also lowers the DAC output impedance by a factor of eight compared

## +3V/+5V, Serial-Input, Voltage-Output, 14-Bit DACs

to a standard R-2R ladder, allowing unbuffered operation in medium-load applications.

The MAX5142/MAX5144 provide matched bipolar offset resistors, which connect to an external op amp for bipolar output swings (Figure 2b).

### Digital Interface

The MAX5141–MAX5144 digital interface is a standard 3-wire connection compatible with SPI/QSPI/MICROWIRE interfaces. The chip-select input ( $\overline{CS}$ ) frames the serial data loading at the data-input pin (DIN). Immediately following  $\overline{CS}$ 's high-to-low transition, the data is shifted synchronously and latched into the input register on the rising edge of the serial clock input (SCLK). After 16 bits (14 data bits, plus two subbits set to zero) have been loaded into the serial input register, it transfers its contents to the DAC latch on  $\overline{CS}$ 's low-to-high transition (Figure 3). Note that if  $\overline{CS}$  is not kept low during the entire 16 SCLK cycles, data will be corrupted. In this case, reload the DAC latch with a new 16-bit word.

### Clearing the DAC

A 20ns (min) logic low pulse on  $\overline{CLR}$  asynchronously clears the DAC buffer to code 0 in the MAX5141/MAX5143 and to code 8192 in the MAX5142/MAX5144.

### External Reference

The MAX5141–MAX5144 operate with external voltage references from +2V to  $V_{DD}$ . The reference voltage determines the DAC's full-scale output voltage.

### Power-On Reset

The power-on reset circuit sets the output of the MAX5141/MAX5143 to code 0 and the output of the MAX5142/MAX5144 to code 8192 when  $V_{DD}$  is first

applied. This ensures that unwanted DAC output voltages will not occur immediately following a system power-up, such as after a loss of power.

## Applications Information

### Reference and Ground Inputs

The MAX5141–MAX5144 operate with external voltage references from +2V to  $V_{DD}$ , and maintain 14-bit performance if certain guidelines are followed when selecting and applying the reference. Ideally, the reference's temperature coefficient should be less than 0.5ppm/°C to maintain 14-bit accuracy to within 1LSB over the -40°C to +85°C extended temperature range. Since this converter is designed as an inverted R-2R voltage-mode DAC, the input resistance seen by the voltage reference is code dependent. In unipolar mode, the worst-case input-resistance variation is from 11.5k $\Omega$  (at code 2155 hex) to 200k $\Omega$  (at code 0000 hex). The maximum change in load current for a +2.5V reference is  $+2.5V / 11.5k\Omega = 217\mu A$ ; therefore, the required load regulation is 28ppm/mA for a maximum error of 0.1LSB. This implies a reference output impedance of less than 72m $\Omega$ . In addition, the signal-path impedance from the voltage reference to the reference input must be kept low because it contributes directly to the load-regulation error.

The requirement for a low-impedance voltage reference is met with capacitor bypassing at the reference inputs and ground. A 0.1 $\mu F$  ceramic capacitor with short leads between REF and GND provides high-frequency bypassing. A surface-mount ceramic chip capacitor is preferred because it has the lowest inductance. An additional 1 $\mu F$  between REF and GND provides low-frequency bypassing. A low-ESR tantalum, film, or organic semiconductor capacitor works well. Leaded capacitors are acceptable because impedance is not as criti-

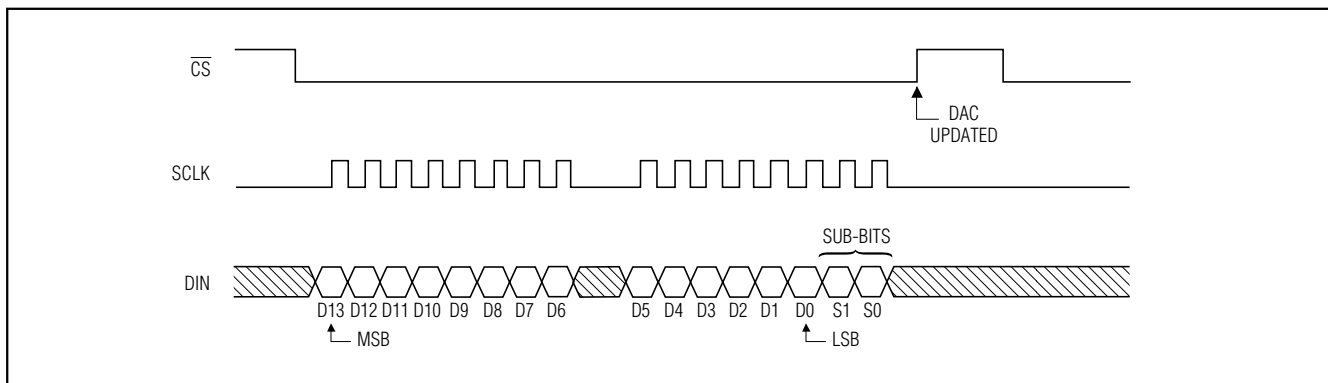

Figure 3. MAX5141–MAX5144 3-Wire Interface Timing Diagram



## +3V/+5V, Serial-Input, Voltage-Output, 14-Bit DACs

cal at lower frequencies. The circuit can benefit from even larger bypassing capacitors, depending on the stability of the external reference with capacitive loading.

### Unbuffered Operation

Unbuffered operation reduces power consumption as well as offset error contributed by the external output buffer. The R-2R DAC output is available directly at OUT, allowing 14-bit performance from +V<sub>REF</sub> to GND without degradation at zero scale. The DAC's output impedance is also low enough to drive medium loads ( $R_L > 60k\Omega$ ) without degradation of INL or DNL; only the gain error is increased by externally loading the DAC output.

### External Output Buffer Amplifier

The requirements on the external output buffer amplifier change whether the DAC is used in unipolar or bipolar operational mode. In unipolar mode, the output amplifier is used in a voltage-follower connection. In bipolar mode (MAX5142/MAX5144 only), the amplifier operates with the internal scaling resistors (Figure 2b). In each mode, the DAC's output resistance is constant and is independent of input code; however, the output amplifier's input impedance should still be as high as possible to minimize gain errors. The DAC's output capacitance is also independent of input code, thus simplifying stability requirements on the external amplifier.

In bipolar mode, a precision amplifier operating with dual power supplies (such as the MAX400) provides the  $\pm V_{REF}$  output range. In single-supply applications, precision amplifiers with input common-mode ranges including GND are available; however, their output swings do not normally include the negative rail (GND) without significant degradation of performance. A single-supply op amp, such as the MAX495, is suitable if the application does not use codes near zero.

Since the LSBs for a 14-bit DAC are extremely small (152.6 $\mu$ V for  $V_{REF} = +2.5V$ ), pay close attention to the external amplifier's input specification. The input offset voltage can degrade the zero-scale error and might require an output offset trim to maintain full accuracy if the offset voltage is greater than 1/2LSB. Similarly, the input bias current multiplied by the DAC output resistance (typically 6.25k $\Omega$ ) contributes to zero-scale error. Temperature effects also must be taken into consideration. Over the -40°C to +85°C extended temperature range, the offset voltage temperature coefficient (referenced to +25°C) must be less than 0.95 $\mu$ V/°C to add less than 1/2LSB of zero-scale error. The external amplifier's input resistance forms a resistive divider with

the DAC output resistance, which results in a gain error. To contribute less than 1/2LSB of gain error, the input resistance typically must be greater than:

$$6.25k\Omega \times 2^{15} = 205M\Omega$$

The settling time is affected by the buffer input capacitance, the DAC's output capacitance, and PC board capacitance. The typical DAC output voltage settling time is 1 $\mu$ s for a full-scale step. Settling time can be significantly less for smaller step changes. Assuming a single time-constant exponential settling response, a full-scale step takes 10.4 time constants to settle to within 1/2LSB of the final output voltage. The time constant is equal to the DAC output resistance multiplied by the total output capacitance. The DAC output capacitance is typically 10pF. Any additional output capacitance increases the settling time.

The external buffer amplifier's gain-bandwidth product is important because it increases the settling time by adding another time constant to the output response. The effective time constant of two cascaded systems, each with a single time-constant response, is approximately the root square sum of the two time constants. The DAC output's time constant is 1 $\mu$ s / 10.4 = 96ns, ignoring the effect of additional capacitance. If the time constant of an external amplifier with 1MHz bandwidth is 1 / 2 $\pi$  (1MHz) = 159ns, then the effective time constant of the combined system is:

$$\sqrt{(96ns)^2 + (159ns)^2} = 186ns$$

This suggests that the settling time to within 1/2LSB of the final output voltage, including the external buffer amplifier, will be approximately 10.4  $\times$  186ns = 1.93 $\mu$ s.

### Digital Inputs and Interface Logic

The digital interface for the 14-bit DAC is based on a 3-wire standard that is compatible with SPI, QSPI, and MICROWIRE interfaces. The three digital inputs ( $\overline{CS}$ , DIN, and SCLK) load the digital input data serially into the DAC.

A 20ns (min) logic low pulse to  $\overline{CLR}$  clears the data in the DAC buffer.

All of the digital inputs include Schmitt-trigger buffers to accept slow-transition interfaces. This means that optocouplers can interface directly to the MAX5141-MAX5144 without additional external logic. The digital inputs are compatible with TTL/CMOS-logic levels.

# +3V/+5V, Serial-Input, Voltage-Output, 14-Bit DACs

## Unipolar Configuration

Figure 2a shows the MAX5141–MAX5144 configured for unipolar operation with an external op amp. The op amp is set for unity gain, and Table 1 lists the codes for this circuit. Bipolar MAX5142/MAX5144 can also be used in unipolar configuration by connecting RFB and INV to REF. This allows the DAC to power up to midscale.

## Bipolar Configuration

Figure 2b shows the MAX5141–MAX5144 configured for bipolar operation with an external op amp. The op amp is set for unity gain with an offset of  $-1/2V_{REF}$ . Table 2 shows the offset binary codes for this circuit (less than 0.25 inches).

## Power-Supply Bypassing and Ground Management

Bypass  $V_{DD}$  with a  $0.1\mu\text{F}$  ceramic capacitor connected between  $V_{DD}$  and GND. Mount the capacitor with short leads close to the device (less than 0.25 inches).

**Table 1. Unipolar Code Table**

DAC LATCH CONTENTS		ANALOG OUTPUT, $V_{OUT}$
MSB	LSB	
1111	1111 1111 11	$V_{REF} \times (16,383 / 16,384)$
1000	0000 0000 00	$V_{REF} \times (8192 / 16,384) = 1/2V_{REF}$
0000	0000 0000 01	$V_{REF} \times (1 / 16,384)$

**Table 2. Bipolar Code Table**

DAC LATCH CONTENTS		ANALOG OUTPUT, $V_{OUT}$
MSB	LSB	
1111	1111 1111 11	$+V_{REF} \times (8191 / 8192)$
1000	0000 0000 01	$+V_{REF} \times (1 / 8192)$
1000	0000 0000 00	0V
0111	1111 1111 11	$-V_{REF} \times (1 / 8192)$
0000	0000 0000 00	$-V_{REF} \times (8192 / 8192) = -V_{REF}$

## Functional Diagrams

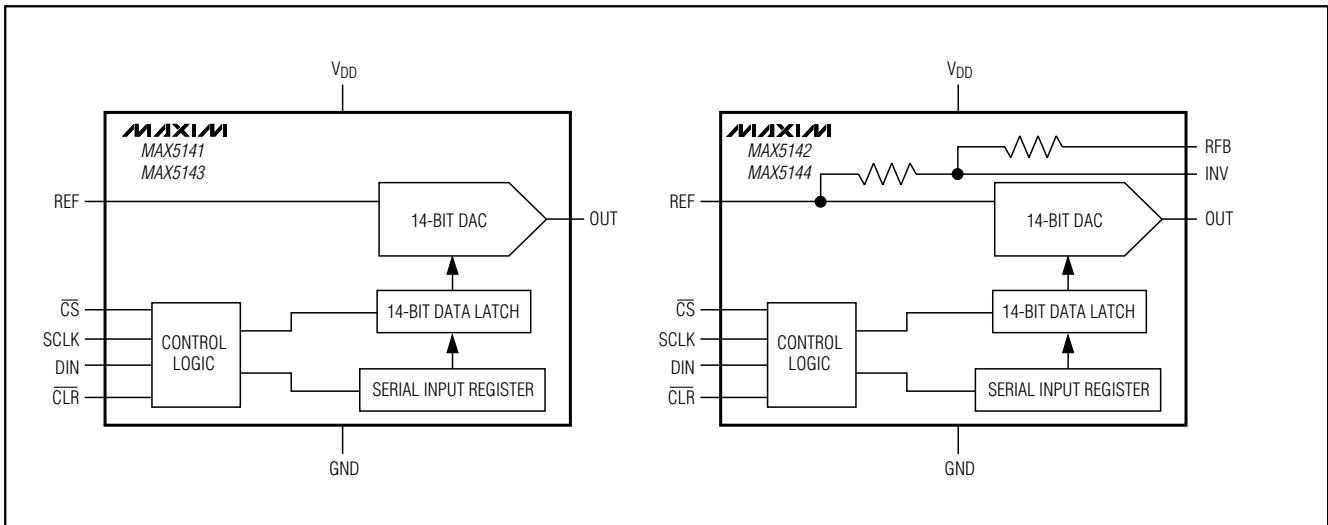

## Chip Information

TRANSISTOR COUNT: 2800

PROCESS: BiCMOS

# +3V/+5V, Serial-Input, Voltage-Output, 14-Bit DACs

## Package Information

**MAX5141-MAX5144**

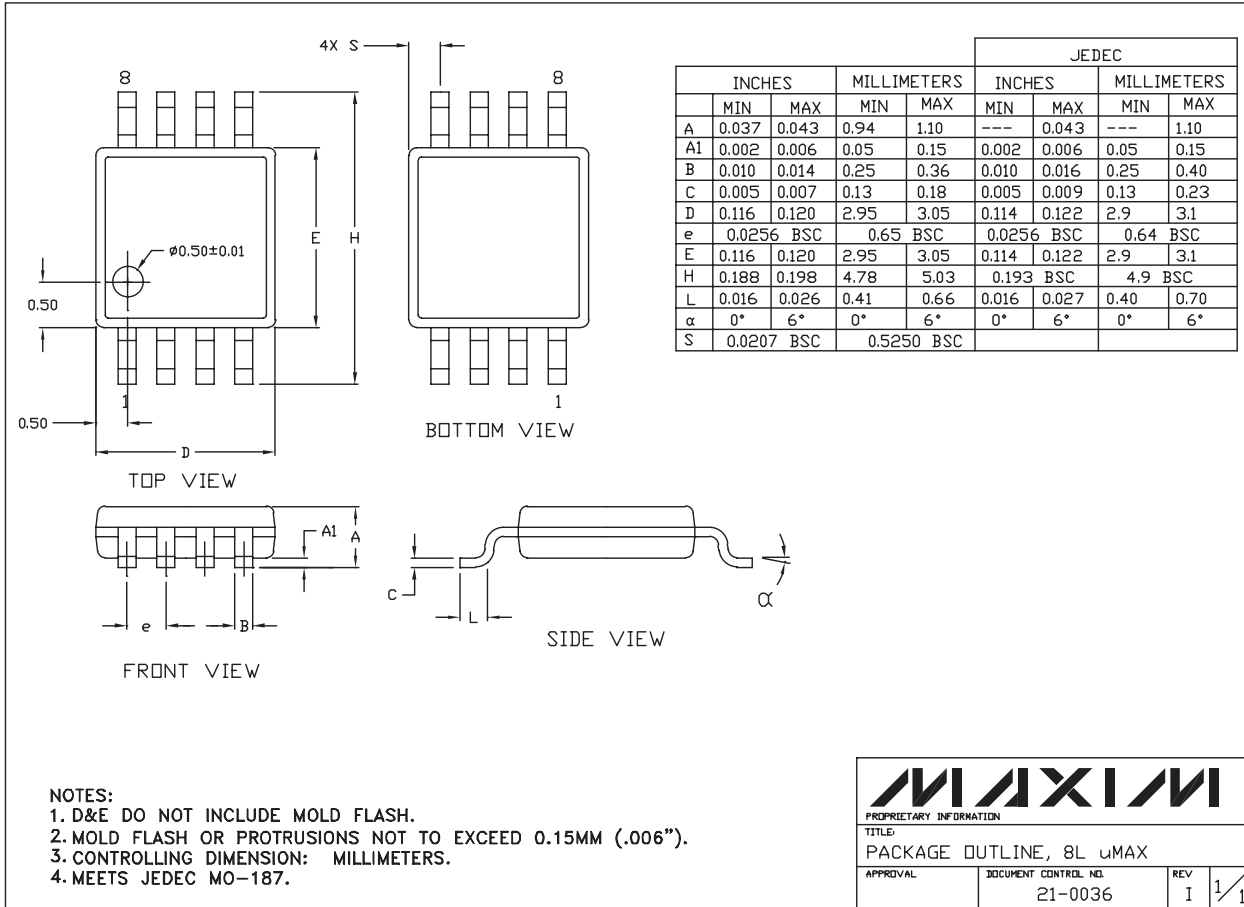

8LUMAXD EPS

# +3V/+5V, Serial-Input, Voltage-Output, 14-Bit DACs

## Package Information (continued)

10LUMAX.EPS

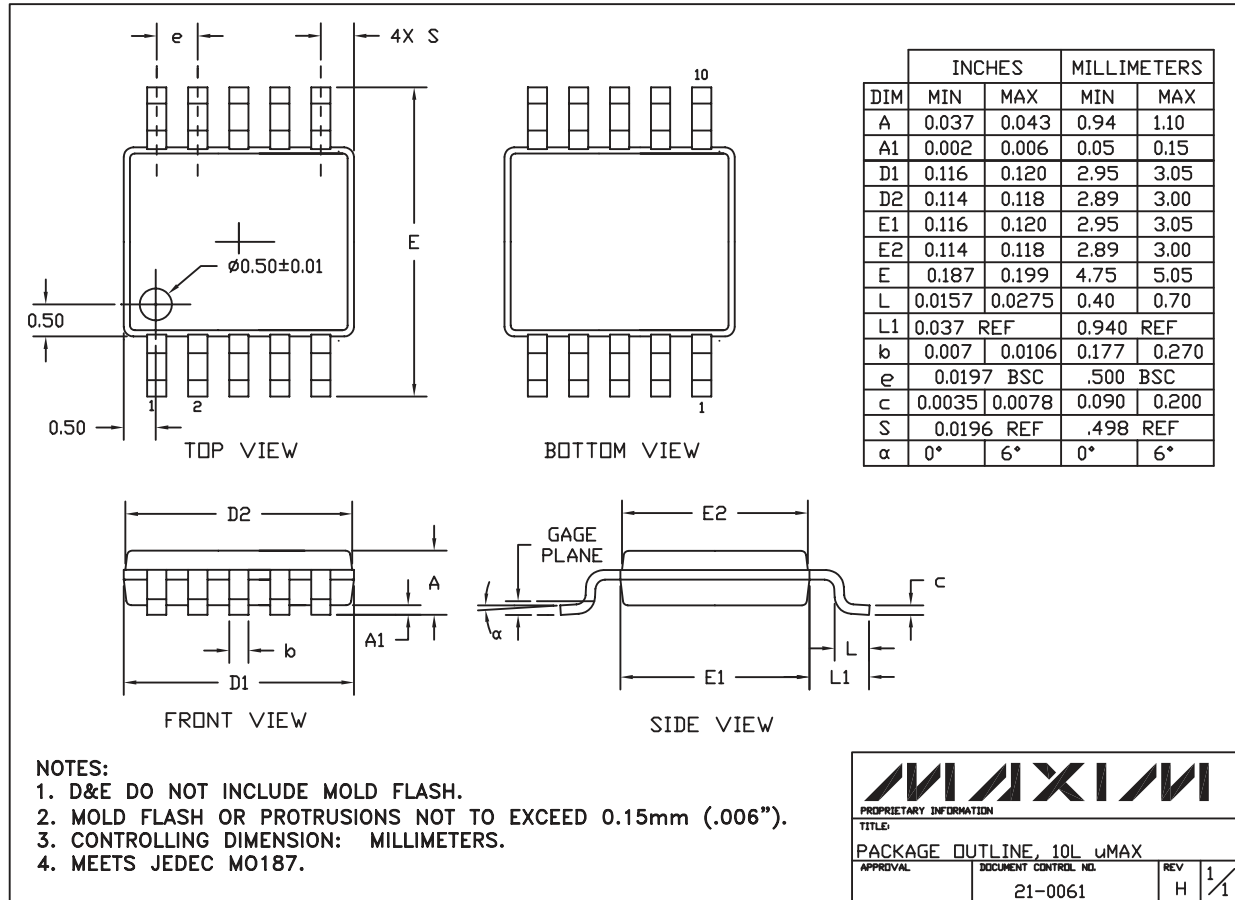

Maxim cannot assume responsibility for use of any circuitry other than circuitry entirely embodied in a Maxim product. No circuit patent licenses are implied. Maxim reserves the right to change the circuitry and specifications without notice at any time.

Maxim Integrated Products, 120 San Gabriel Drive, Sunnyvale, CA 94086 408-737-7600 12