

S505H

5 mm x 20 mm 400 Vdc/500-600 Vac time-delay fuse



Product features

- 400 Vdc/500-600 Vac rating
- Time-delay, high breaking capacity
- 5 mm x 20 mm physical size
- Ceramic tube with plated end cap construction
- Designed to IEC 60127-2, Standard, Sheet 5
- Optional axial leads available
- [Fuse accessories guide \(holders, clips\)](#)

Ordering part number

The ordering code is the part number replacing the “ ” with a “-”

BK-S505H-V-6-3-R

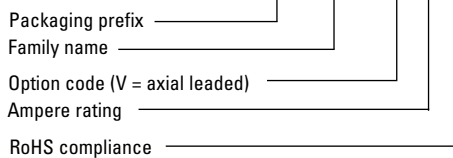

Packaging prefix

- **Blank:** 5 cartridge parts in a 5 inch tin, 4 axial lead parts in a 5 inch tin (Values < 12 A only)
- **BK-:** 100 parts packed in a cardboard carton (axial leaded only)
- **BK1-:** 1000 parts in a poly bag (cartridge version only)
- **TR2-** 1500 parts on a reel (axial lead V option only, values < 12 A only)

Option code

- **-V :** (Axial leads – copper tinned wire with nickel plated brass end caps)

Applications

- Power supplies - adapters
- Desktops/notebooks
- TVs / Displays
- Set top boxes
- Lighting ballasts
- Battery chargers
- Printers
- Game systems
- Air conditioners

Agency information

S505H-XXX-R (Cartridge)

- cURus Recognition file: E56412, Guide JFHR2,JFHR8, (500 mA - 10 A); E19180, Guide JDYX2 and JDYX8, (12 A - 20 A)
- CCC Approval: 500 mA - 10 A, Cert. No.: 2020970207000249
- TUV Approval: 2 A - 10 A, Cert. No.: R50297821
- PSE Approval: 1 A - 5 A, Cert. No.: JET1641-31003-1025; 6.3 A - 10 A JET1641-31003-1023
- KC Approval: SU05011-21001A (1 A - 2.5 A), SU05011-21002A (3.15 A - 6.3 A), SU05011-21003A (8 A -10 A), SU05011-21004A (500 mA - 800 mA)

S505H-V-XXX-R (Axial leads)

- cURus Recognition file: E56412, Guide JFHR2,JFHR8, (500 mA - 10 A) E19180, Guide JDYX2 and JDYX8, (12 A - 20 A)
- PSE Approval: 1 A - 5 A, Cert. No.:JET164131003-1026; 6.3 A - 10 A, Cert. No: JET1641-31003-1024
- CCC Approval: 500 mA - 10 A, Cert. No.: 2020970207000249
- TUV Approval: 500 mA-10 A, Cert. No.: R50297821
- KC Approval: SU05011-21001A (1 A - 2.5 A), SU05011-21002A (3.15 A - 6.3 A), SU05011-21003A (8 A -10 A), SU05011-21004A (500 mA - 800 mA)



Environmental compliance



Powering Business Worldwide

Electrical characteristics

Amp Rating	1.5 In minimum minutes	2.1 In maximum minutes	2.75 In minimum ms	maximum seconds	4.0 In minimum ms	maximum seconds	10 In minimum ms	maximum ms
500 mA - 1 A	60	30	250	80	50	5	5	150
1 A - 3.15 A	60	30	750	80	95	5	10	150
4 A - 6.3 A	60	30	750	80	150	5	10	150
8 A - 10 A	30	30	750	80	150	5	10	150
12 A - 20 A	30*	30	750	80	150	8	10	150

* 1.5 In rating for cartridge version only

Product specifications

Part number	Current rating (A)	Voltage rating ¹ (Vac)	Voltage rating ¹ (Vdc)	Interrupting rating @ rated voltage (A) @			Typical DC cold resistance ⁵ (Ω)	Typical voltage drop ⁶ (mV)	Typical melting I ² t (A ² s)	Agency approvals			cURus ⁹
				250 Vac ²	600 Vac ³	400 Vdc ⁴				250 Vac Tuv	CCC	PSE/JET	
S505H(-V)-500-R	0.5	600	400	1500	100	1500	0.507	295	0.188	x ⁸	x		x
S505H(-V)-800-R	0.8	600	400	1500	100	1500	0.237	189	0.632	x ⁸	x		x
S505H(-V)-1-R	1	600	400	1500	100	1500	0.157	176	1.28	x ⁸	x	x	x
S505H(-V)-1.25-R	1.25	600	400	1500	100	1500	0.108	150	2.22	x ⁸	x	x	x
S505H(-V)-1.6-R	1.6	600	400	1500	100	1500	0.070	125	6.78	x ⁸	x	x	x
S505H(-V)-2-R	2	600	400	1500	100	1500	0.055	128	11.44	x	x	x	x
S505H(-V)-2.5-R	2.5	600	400	1500	100	1500	0.040	126	24.23	x	x	x	x
S505H(-V)-3.15-R	3.15	600	400	1500	100	1500	0.031	121	43.55	x	x	x	x
S505H(-V)-4-R	4	600	400	1500	100	1500	0.019	90	38.45	x	x	x	x
S505H(-V)-5-R	5	600	400	1500	100	1500	0.015	89	71.30	x	x	x	x
S505H(-V)-6.3-R	6.3	500	400	1500	100 @ 500 Vac	1500	0.011	80	111.4	x	x	x	x
S505H(-V)-8-R	8	500	400	1500	100 @ 500 Vac	1500	0.007	76	228.2	x	x	x	x
S505H(-V)-10-R	10	500	400	1500	100 @ 500 Vac	1500	0.006	72	349.5	x	x	x	x
S505H(-V)-12-R	12	500	400	na	200 @ 500 Vac	300	0.00545	80	550				x
S505H(-V)-15-R	15	500	400	na	200 @ 500 Vac	300	0.004	75	900				x
S505H(-V)-16-R	16	500	400	na	200 @ 500 Vac	300	0.0037	68	1100				x
S505H(-V)-20-R	20	500	na	na	200 @ 500 Vac	na	0.00325	75	1500				x

1. Voltage rating: based on the interrupting rating test according to UL.

2. Interrupting rating of 250 Vac/1500 A is tested by all agency approvals, test condition is 250 Vac, PF: 0.7 - 0.8.

3. Interrupting rating of Vac is tested with, PF:1.0 (500 mA - 5 A @ 600 Vac, 6.3 A - 20 A @ 500 Vac)

4. Interrupting rating of Vdc is tested under capacitor bank for 500 mA to 10A; Vdc interrupting rating for 12 A–20 A is tested under power supply with time constant less than 1 ms.

5. Typical cold resistance measured at <10% rated current.

6. Typical voltage drop measured under ambient +20 °C with rated current

7. Typical melting I²t: Measured at 10 In DC

8. Axial lead version only.

9. 600/500 Vac, 400 Vdc.

Dimensions- mm

Drawing not to scale

500 mA - 10 A

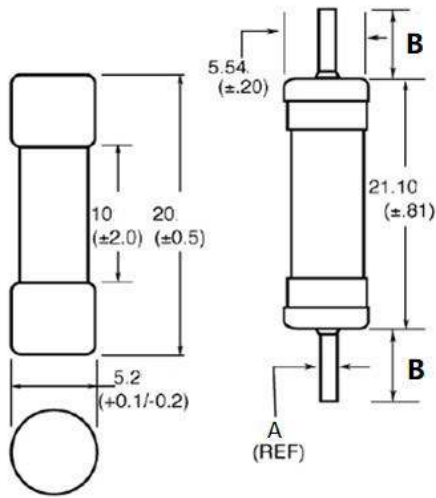

Dimension	Value (mm)
A	0.65 (500 mA - 6.3 A) 0.80 (8 A - 10 A)
B	38.1 ±0.38 (BK packaging) 15.8 ±2.0 (TR2 packaging)

12 A - 20 A

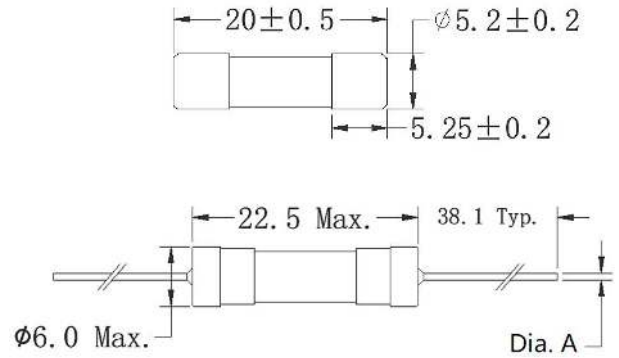

Dimension	Value (mm)
A	1.0 ±0.05 (12 A - 15 A) 1.2 ±0.05 (16 A - 20 A)

General specifications

Operating temperature: -55 °C to +125 °C (with proper derating) [500 mA - 20 A]

Temperature derating curve

(500 mA - 10 A)

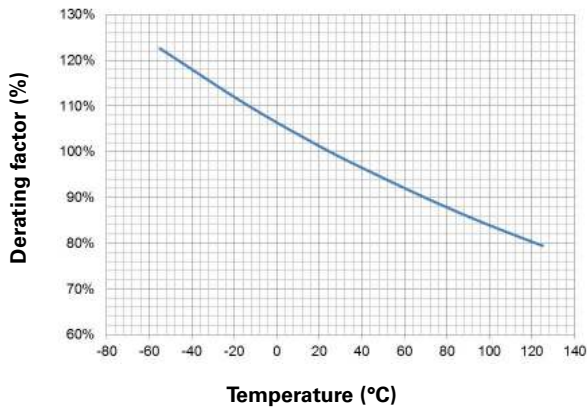

(12 A - 20 A)

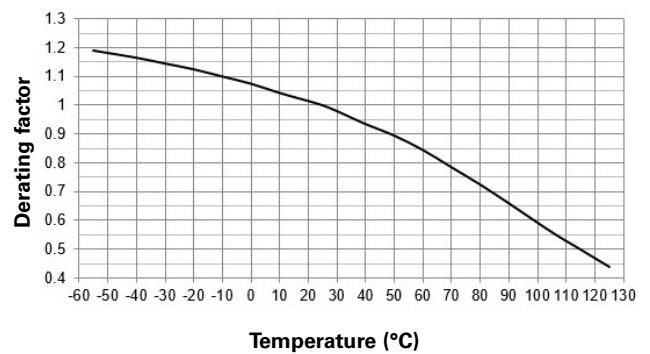

Time vs. current curve

(500 mA - 10 A)

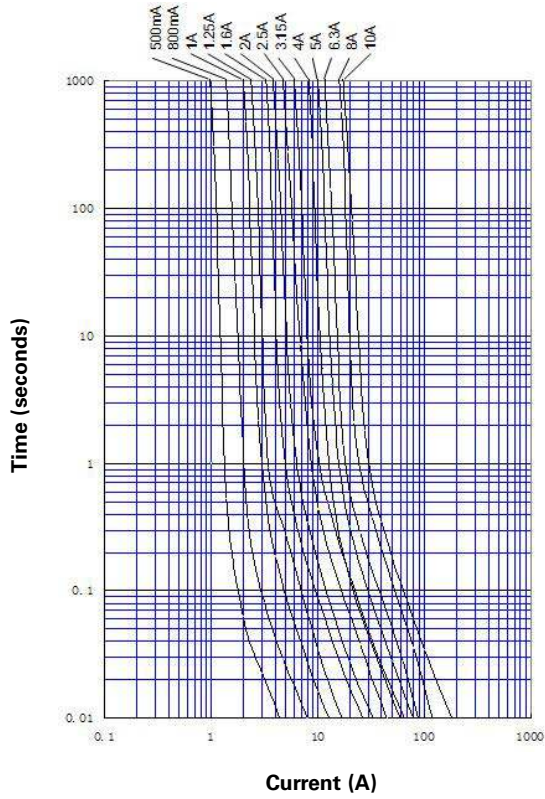

(12 A - 20 A)

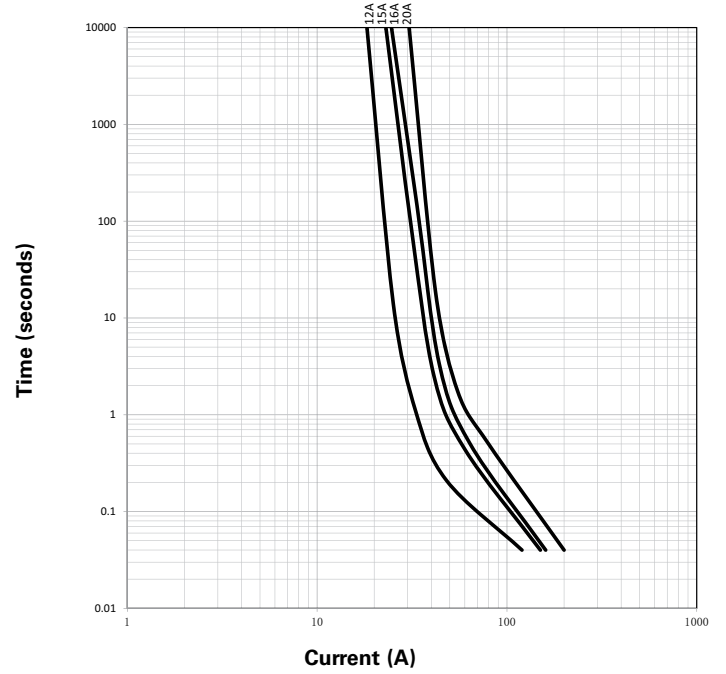

I²t vs. current

(500 mA - 10 A)

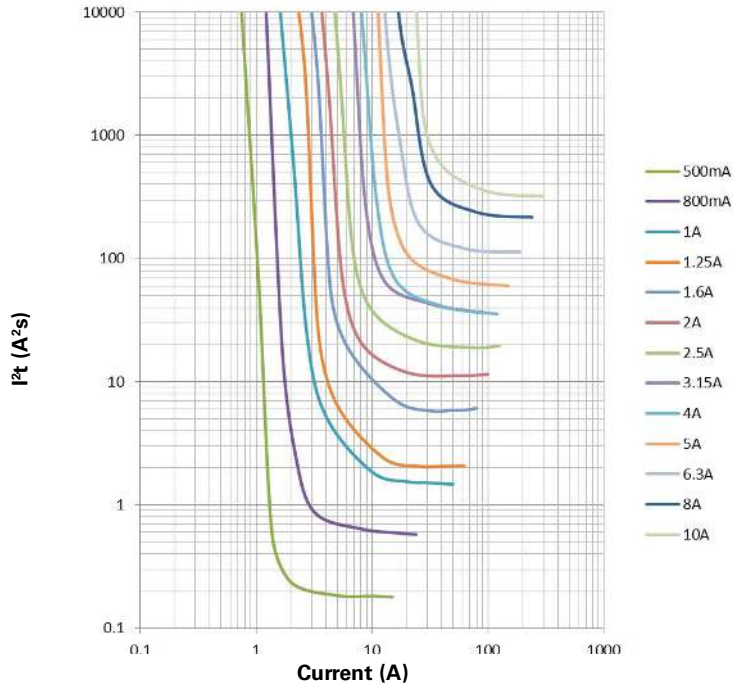

(12 A - 20 A)

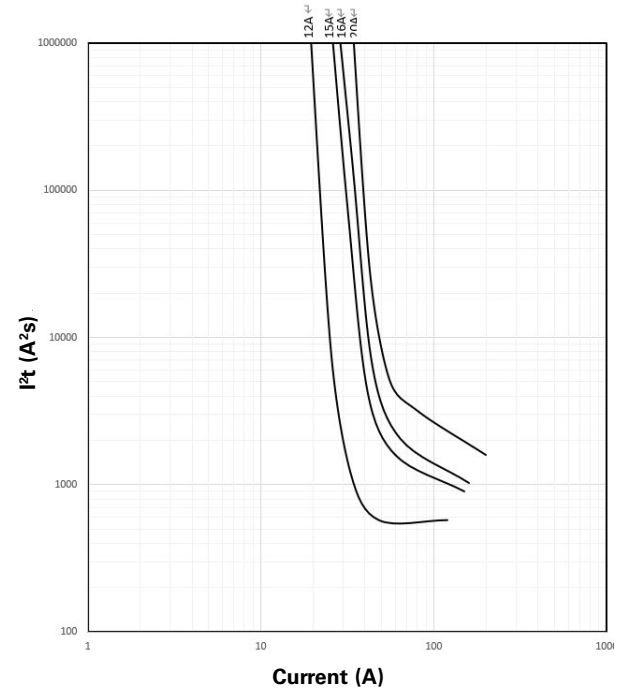

I²t vs. time curve

(500 mA - 10 A)

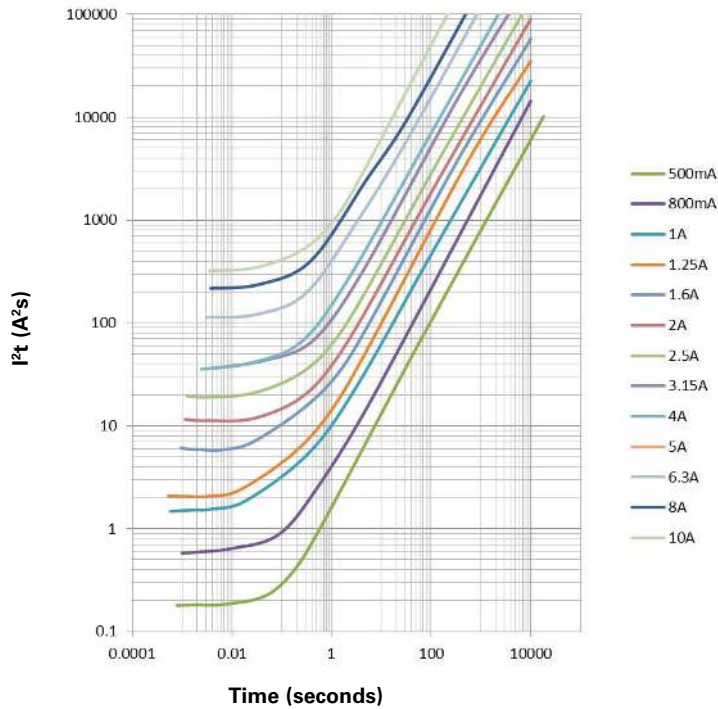

(12 A - 20 A)

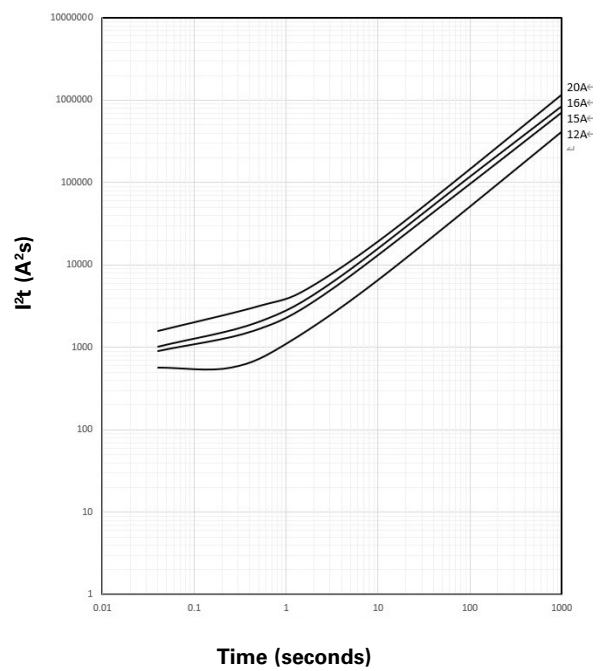

Wave solder profile (Axial lead only)

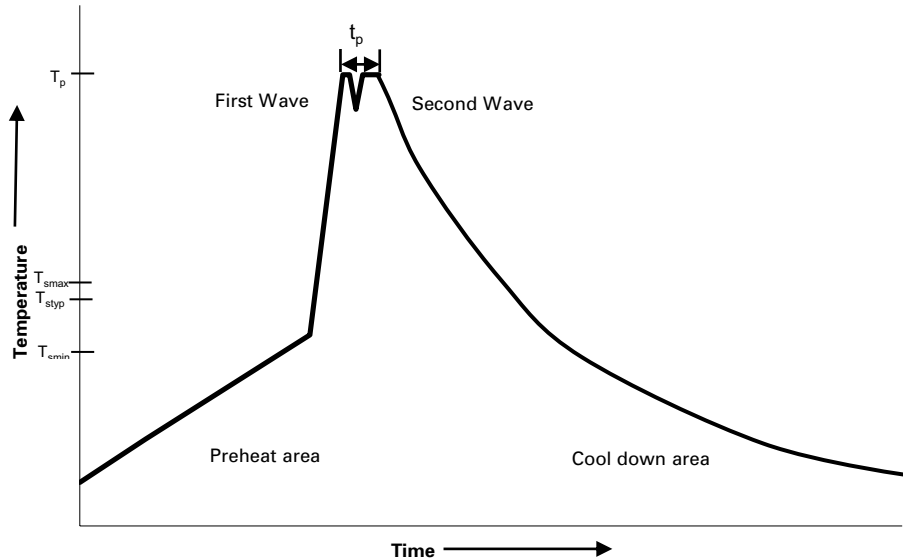

Reference EN 61760-1:2006

Profile feature	Standard SnPb solder	Lead (Pb) free solder
Preheat		
• Temperature min. (T_{smin})	100 °C	100 °C
• Temperature typ. (T_{styp})	120 °C	120 °C
• Temperature max. (T_{smax})	130 °C	130 °C
• Time (T_{smin} to T_{smax}) (t_s)	70 seconds	70 seconds
Δ preheat to max Temperature	150 °C max.	150 °C max.
Peak temperature (T_p)*	235 °C – 260 °C	250 °C – 260 °C
Time at peak temperature (t_p)	10 seconds max 5 seconds max each wave	10 seconds max 5 seconds max each wave
Ramp-down rate	~ 2 K/s min ~3.5 K/s typ ~5 K/s max	~ 2 K/s min ~3.5 K/s typ ~5 K/s max
Time 25 °C to 25 °C	4 minutes	4 minutes

Manual solder

+350 °C (4-5 seconds by soldering iron), generally manual/hand soldering is not recommended.

Life Support Policy: Eaton does not authorize the use of any of its products for use in life support devices or systems without the express written approval of an officer of the Company. Life support systems are devices which support or sustain life, and whose failure to perform, when properly used in accordance with instructions for use provided in the labeling, can be reasonably expected to result in significant injury to the user.

Eaton reserves the right, without notice, to change design or construction of any products and to discontinue or limit distribution of any products. Eaton also reserves the right to change or update, without notice, any technical information contained in this bulletin.

Eaton
Electronics Division
1000 Eaton Boulevard
Cleveland, OH 44122
United States
Eaton.com/electronics

© 2023 Eaton
All Rights Reserved
Printed in USA
Publication No. 4406
June 2023

Eaton is a registered trademark.

All other trademarks are property of their respective owners.

Follow us on social media to get the latest product and support information.

