

GENERAL DESCRIPTION

The PEN modules are designed for the implementation of low-voltage power converters. The mechanical design is tailored for 19" rack integration with simple interconnections and direct connection to a BoomBox, or any other control platform.

Each module contains a NPC cell, corresponding to four power switches and two diodes.

Direct access to the gating signals is offered using optical fiber inputs, while embedded measurement circuits provide direct analog outputs related to one of the half DC link voltages and the AC output current using galvanically-isolated sensors.

Overvoltage, over-current and over-temperature protections are also integrated on the board for safer use in R&D applications. Besides, these protections are user-programmable through a simple onboard microcontroller and a CPLD.

Finally, the possibility to use alternative or customized mezzanine boards enables the compatibility with future developments and onboard data processing.

TYPICAL APPLICATIONS

The modules are ideally suited to build up ambitious prototypes of low-voltage NPC power converters, ranging from conventional three-phase three-level inverters to more complex multilevel topologies. Typical power ratings are around 10 kW, depending on the nominal DC link voltage and the switching frequency.

ELECTRIC SCHEME

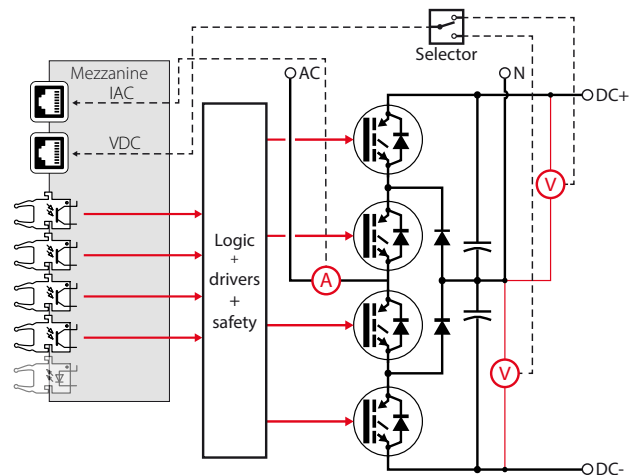

KEY FEATURES AND SPECIFICATIONS

- 18 A / 800 V maximum ratings, limited by losses
- 600 V / 30 A IGBTs
- 90 A max pulsed current (t_p limited by $T_{J,max}$)
- 120 W TDP envelope
- 2x 517 μ F / 400 V half DC buses
- Up to 50 kHz switching frequency
- 4 optical inputs / 1 optical output
- 2 analog outputs
- +5V and +12V power supplies
- Embedded voltage and current measurement (Upper or lower half-bus voltage measurement)
- Over voltage/current/temperature protection
- User-configurable CPLD
- 100x330 mm Eurocard form factor
- Forward compatible with imperix RealSync technology and the related mezzanine board

MAIN COMPONENTS

Component	Devices	Main specifications
Power switches	1x Vincotech P924F33 module	See below or device datasheet
Capacitors	2x 517 uF Panasonic EEU-EE2W470S (2 banks of 11x47uF each)	450V, $I_{\text{RIPPLE}} = 0.42 \text{ Arms per capacitor @ 120 Hz}$
Drivers	4x Avago ACPL-P345	1A, 50 kV/ μs , $V_{\text{IORM}} = 1.14 \text{ kVpeak}$
Isolated DC/DC Converters	4x Recom RK-0515S	5-15V, 1W, $V_{\text{ISO}} = 3 \text{ kVDC (1s)}$
Current sensor	1x LEM HLSR 20-P/SP33	$\pm 20 \text{ A}$, 450 kHz, $\pm 1\%$ accuracy
Voltage sensor	1x Resistive divider + Avago ACPL-C87B	100 kHz, $\pm 0.1\%$ accuracy
Heatsinks	1x Dynatron G199	0.33 °C/W @ full speed
CPLD	1x Xilinx XC9536XL-10VQG44C	10 ns, 36 macrocells
Microcontrollers	2x Microchip PIC24F04KA101	16 bits, 16 Mhz, 9x 10-bit ADC @ 500kps

ABSOLUTE MAXIMUM RATINGS

Parameter	Symbol	Test conditions	Min.	Typ.	Max.	Unit
Maximum half DC bus voltage ¹	$V_{\text{DC,UP,max}}$ $V_{\text{DC,LOW,max}}$		-	450	-	V
Maximum continuous leg current ²	$I_{\text{arm,max}}$	$T_j = 25^\circ\text{C}$		18		Arms
Maximum DC bus ripple current (at 120 Hz) ³	I_{RIPPLE}	$T_j = 105^\circ\text{C}$	-	4.7	-	Arms
Maximum working isolation voltage	V_{IORM}		-	tbd.	-	V_{PEAK}
Highest allowable isolation voltage (1s)	V_{IOTM}		-	3.0	-	kV_{PEAK}
Supply voltage	5V0		4.2	5.0	5.8	V
	12V ⁴		4.5	12.0	14.0	V
Highest allowable junction temperature	$T_{\text{J(max)}}$		-	175	-	°C

¹ The maximum DC bus voltage is defined by the specifications of the bus capacitors. Therefore, as for any aluminium electrolytic capacitors, few short-term overvoltages can be tolerated, provided that they involve limited amounts of energy.

² In cold conditions, the maximum operating current is limited by the power semiconductors. Otherwise, the current rating of the module is limited by the power envelope of the cooler (about 40 W with airflow).

³ The maximum ripple current is defined by the equivalent series resistance (ESR) of the capacitors and relates to Joule losses and lifetime considerations. Therefore, this value can be exceeded, provided that the operating temperature of the capacitors remains low.

⁴ The 12V supply is entirely independent from the module and serves only to supply the cooling fan.

POWER CHARACTERISTICS

Parameter	Symbol	Min.	Typ.	Max.	Unit	
IGBT blocking voltage	I_{CES}	$T_j = 5^\circ\text{C}$	-	600	-	V
IGBT continuous collector current	$I_{\text{C,IGBT}}$	$T_j = 175^\circ\text{C}$, $T_h = 80^\circ\text{C}$	-	30	-	A
Diode continuous forward current	$I_{\text{C,diode}}$	$T_j = 175^\circ\text{C}$, $T_h = 80^\circ\text{C}$	-	27	-	A
IGBT pulse collector/diode current	I_{CM}	$T_j = 25^\circ\text{C}$	-	90	-	A
IGBT saturation voltage	$V_{\text{CE(sat)}}$	$I_{\text{C}} = 30 \text{ A}$, $T_j = 25^\circ\text{C}$	1	1.54	1.95	V
		$I_{\text{C}} = 30 \text{ A}$, $T_j = 125^\circ\text{C}$	-	1.75	-	V
Diode forward voltage	V_{F}	$I_{\text{F}} = 30 \text{ A}$, $T_j = 25^\circ\text{C}$	1	1.75	2.05	V
		$I_{\text{F}} = 30 \text{ A}$, $T_j = 125^\circ\text{C}$	-	1.73	-	V
Reverse recovery current	I_{RRM}	$I_{\text{F}} = 30 \text{ A}$, $V_{\text{R}} = 350 \text{ V}$, $R_{\text{gon}} = 16 \Omega$	-	36	-	A
Reverse recovery delay	t_{RR}	$I_{\text{F}} = 30 \text{ A}$, $V_{\text{R}} = 350 \text{ V}$, $R_{\text{gon}} = 16 \Omega$	-	127	-	ns
IGBT thermal resistance junction-to-heatsink	$R_{\text{th,JH,t}}$		-	1.69	-	°C/W
Diode thermal resistance junction-to-heatsink	$R_{\text{th,H,d}}$		-	2.15	-	°C/W
Turn-on losses (inductive load)	E_{on}	$I_{\text{C}} = 30 \text{ A}$, $V_{\text{CE}} = 350 \text{ V}$, $R_{\text{gon}} = 16 \Omega$, $T_j = 25^\circ\text{C}$	-	450	-	μJ
		$I_{\text{C}} = 30 \text{ A}$, $V_{\text{CE}} = 350 \text{ V}$, $R_{\text{gon}} = 16 \Omega$, $T_j = 125^\circ\text{C}$	-	590	-	μJ
Turn-off losses (inductive load)	E_{off}	$I_{\text{C}} = 30 \text{ A}$, $V_{\text{CE}} = 350 \text{ V}$, $R_{\text{goff}} = 16 \Omega$, $T_j = 25^\circ\text{C}$	-	810	-	μJ
		$I_{\text{C}} = 30 \text{ A}$, $V_{\text{CE}} = 350 \text{ V}$, $R_{\text{goff}} = 16 \Omega$, $T_j = 125^\circ\text{C}$	-	1040	-	μJ
Case-to-heatsink isolation voltage	V_{ISO}	DC, $t = 2 \text{ s}$		4		kV
External gate resistance	R_{g}			10		Ω

CURRENT MEASUREMENT CHARACTERISTICS

Parameter	Symbol	Note	Min.	Typ.	Max.	Unit
Optimized accuracy range	I_{OPT}		-	±20	-	A
Measuring range ⁵	I_{FS}		-	±64	-	A
Nominal sensitivity	G	Including a x2 gain on the Mezzanine	-	-46	-	mV/A
Total output error ⁶	G_{ERR}	$T_A = 25^\circ \text{ to } 100^\circ \text{ C}$	-	±1.0	±3.4	%
Bandwidth	f_{3dB}		-	450	-	kHz
Measurable slope	dI/dt		-	50	-	A/μs
Maximum working isolation voltage	V_{IORM}		-	600	-	V_{AC}

VOLTAGE MEASUREMENTS CHARACTERISTICS

Parameter	Symbol	Note	Min.	Typ.	Max.	Unit
Measuring range	V_{OPT}		0.0	-	400	V
Maximum measuring range ⁵	V_{FS}		0.0	-	450	V
Nominal sensitivity	G	Including a x2 gain on the Mezzanine	-	-9.95	-	mV/V
Uncalibrated sensitivity error	G_{ERR}	$25^\circ \text{ to } 125^\circ \text{ C}$, including resistive divider		±2.0		%
Gain error over temperature	$G_{ERR,t}$	$T_A = 25^\circ \text{ to } 100^\circ \text{ C}$		±0.1		%
Bandwidth	f_{3dB}		-	25	-	kHz
Measurable slope	dV/dt		-	220	-	V/μs
Maximum working isolation voltage	V_{IORM}		-	1140	-	V_{DC}

⁵ The integrated current and voltage measurements are isolated onboard. The measured values are available as differential signals on the mezzanine connectors, with voltages ranging in the interval between 0 and 3.3V. In

case imperix ModuLink mezzanine are used, the latter feature an integrated x2 gain.

⁶ When calibrated under stabilized operating temperature conditions, superior performance can be achieved.

COMPATIBLE MEZZANINES

The modules are compatible with various types of mezzanines, including:

» The **ModuLink** mezzanine is meant to provide basic input/output support, featuring optical inputs and analog outputs. Additionally, the error signal is also relayed to the master controller.

» The **RealSync** mezzanine is part of the future generation of the BoomBox control platform and will feature bidirectional Gigabit Ethernet-class communication with the central controller. Besides, the board also embeds an Artix 7 FPGA and a high-end microcontroller. This mezzanine will be publicly released simultaneously with the third generation of the BoomBox hardware.

» Any custom-made mezzanine that fits the mechanical design and possesses the suitable connectors.

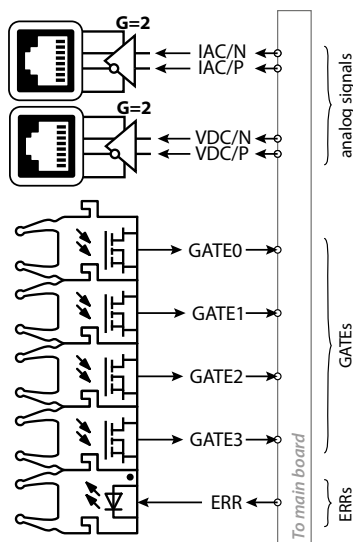

Fig. 1. Functional view of the ModuLink mezzanine.

MAIN FEATURES

Connections

The power connections are located on top of the module, using M3 screw terminals, as shown in Fig. 4. This authorizes an easy reconfiguration of the topology, while guaranteeing robust mechanical contacts.

Voltage measurement selector

The module embeds two distinct voltage sensors, measuring the voltage on each of the half DC busses. The user can select either of these measurements to be wired to the analog output of the mezzanine. When

using multiple modules whose DC busses are paralleled (typically in a 3-phase inverter application), each of the half-busses voltage can be measured by selecting the upper bus on one board, and the lower bus on another.

The selection is made by connecting **two** jumpers in the corresponding header (X9 on Fig. 4). For measuring the upper bus voltage, two jumpers must be placed on P6, and for measuring the lower bus voltage, two jumpers must be placed on P5, as depicted on Fig 2.

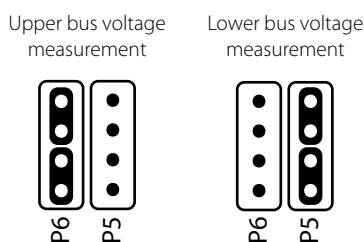

Fig. 2. Voltage measurement selector

Power supply supervision

The main 5V power supply is monitored by the **MCU2** microcontroller, which triggers a fault signal in case of inappropriate voltage. This operation is described in the *embedded circuit logic and protection* section.

User-programmable CPLD

The modules feature a user-programmable CPLD, allowing to easily modify the coding /decoding of the gating signals (from the optical fibers), or to implement special behaviors in case of faults (overvalues).

EMBEDDED LOGIC AND PROTECTION

The modules embed a digital supervisory system that guarantees their integrity by a continuous monitoring of the measurements given by the voltage and current sensors, as well as the temperature probes and power supply voltage. The main components of this circuit are depicted in Fig. 3 and include the following :

- » **MCU1** is continuously sampling the voltage and current at approx. 150 ksp/s. Upon the detection of an overvalue, the MCU triggers the corresponding flag.
- » **MCU2** is continuously sampling slow variables such as temperature, power supply voltage or other measurements. Upon the detection of an overvalue, the MCU triggers the corresponding error flag.
- » The user-programmable **CPLD** is at the heart of the supervisory system and has three main tasks:
 - » Generating the final gating signals based on those received through the optical fibers, possibly involving some decoding of the switching states.
 - » Enforcing a specific switching state in case of a fault. This may be a blocked state or a short circuit depending on the desired behavior and the cause of the fault.
 - » Generating a set of flags based on the faults provided by the microcontrollers.

Default configuration

The modules are provided with a default configuration in which the four optical inputs are directly corresponding to the four gating signals. Besides, the safety thresholds are defined as follows :

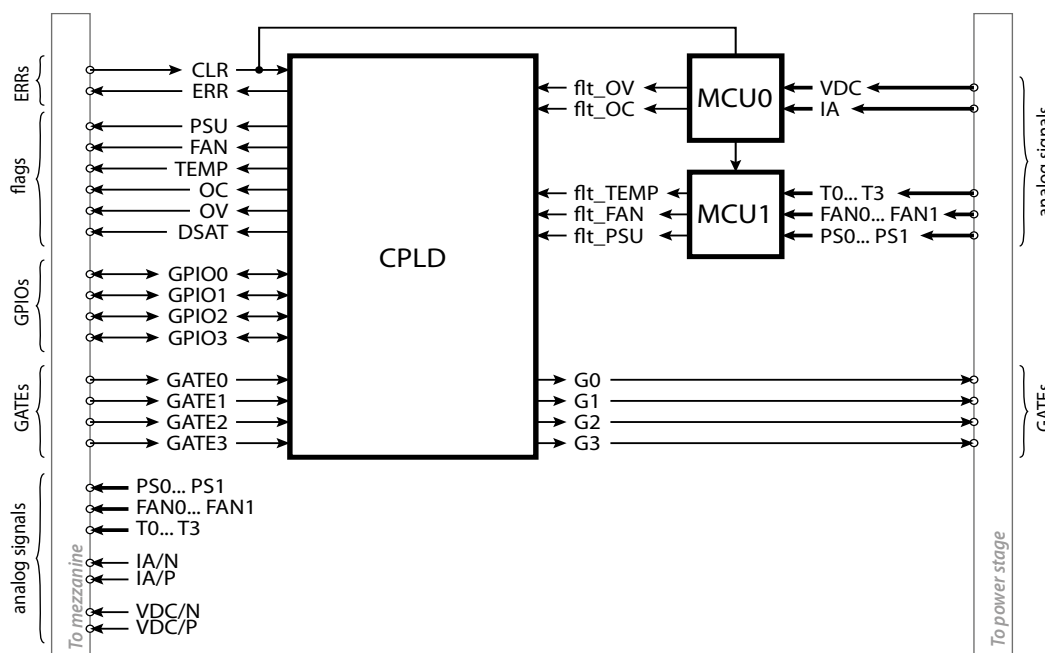

Fig. 3. Onboard protection and logic circuits.

Signal name	Fault-triggering when
Cell output current	$ I_A > 30A$
Capacitor bank voltage	$V_{DC,UP} > 450V$ or $V_{DC,LOW} > 450V$
Heatsink temperature	$T > 90^\circ C$
5V power supply	$V_{5V} < 4.5V$ or $V_{5V} > 5.5V$
PWM	<i>tbd</i>

The global error signal transmitted by the mezzanine is turned off upon a fault detection (active low). When a fault is tripped, it can be acknowledged manually by pressing the corresponding button on the mezzanine.

MECHANICAL DATA

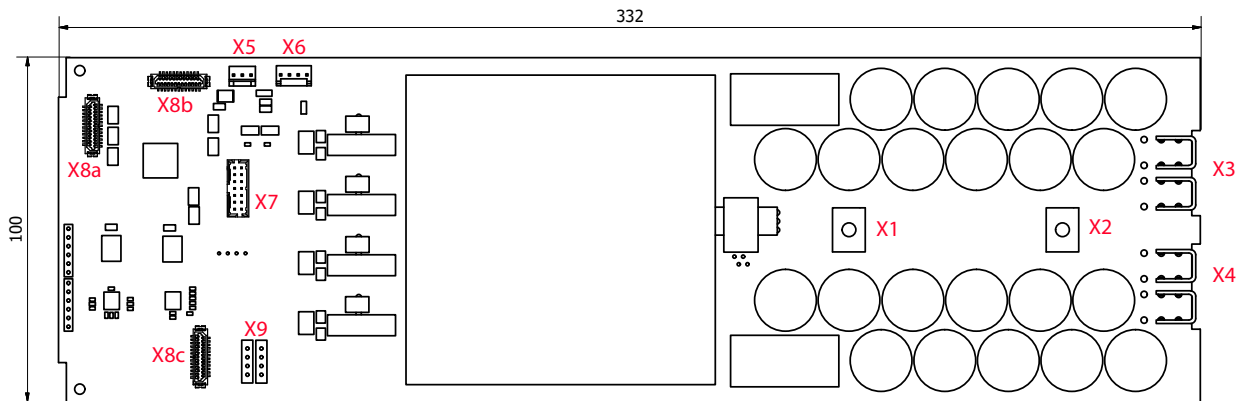

Fig. 4. Mechanical data of PEN modules

Label	Role	Label	Role	Label	Role
X1	AC power terminal	X5	Auxiliary 5V+12V power supply connector	X8a	Mezzanine power supplies connector
X2	Neutral point terminal	X6	Fan power supply connector	X8b	Mezzanine power digital signals connector
X3	DC+ power terminal	X7	CPLD programming JTAG	X8c	Mezzanine analog signals connector
X4	DC- power terminal			X9	Voltage measurement selector (see dedicated section)

Custom configuration

Along with the board, imperix provides a default CPLD source so as to allow the user to implement and reprogram the board with custom firmware in order enable extra features such as :

- » A different coding of the gating signals,
- » A cell bypass function (i.e. custom gating signal configuration in case of faults);
- » Another I/O or safety configuration.

1.1.1.5 MEZZANINE CONNECTORS PINOUT

Three connectors provide the necessary connectivity between the main board of the module and the mezzanine. Their pinout is given below. Imperix can provide details on the mechanical design or 3D file upon request.

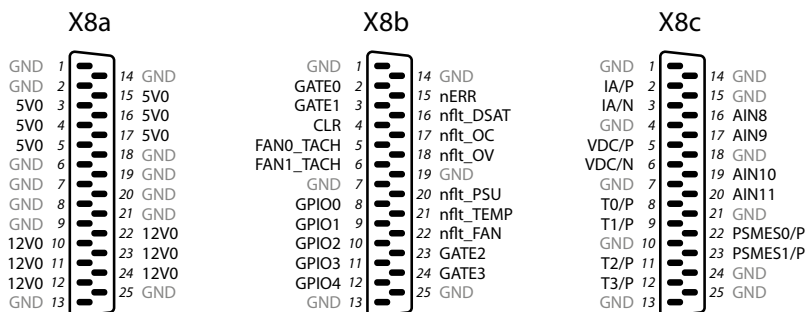

1.1.1.1 ANALOG OUTPUT CONNECTORS PINOUT

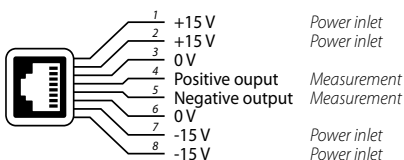

1.1.1.3 MEZZANINE TO MEZZANINE CONNECTOR PINOUT

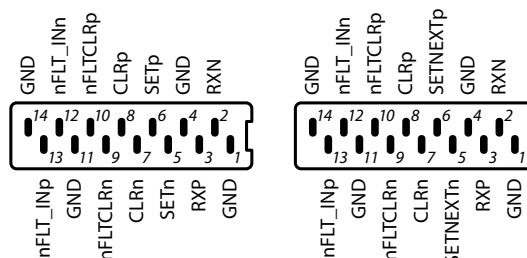

1.1.1.2 POWER SUPPLY CONNECTOR PINOUT (X5)

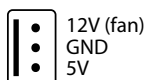

1.1.1.4 P4 - CONTROLLER

P5 - NEXT MODULE

These modules must be used in electric/electronic equipment with respect to applicable standards and safety requirements in accordance with the manufacturer's operating instructions. Caution, risk of electrical shock! When using the devices, certain parts of the modules may carry hazardous voltages (e.g. power supplies, bus-bars, etc.). Disregarding this warning may lead to injury and/or cause serious damage. All conducting parts must be inaccessible after installation.

CONTACT

imperix Ltd.

Rue de la Dixence 10
1950 Sion, Switzerland
phone: +41 (0)27 552 06 60
fax: +41 (0)27 552 06 69
www.imperix.ch, sales@imperix.ch

ABOUT US

Imperix Ltd. is a company established in Sion, Switzerland. Its name is derived from the Latin verb *imperare*, which stands for controlling and refers to the company's core business: the control of power electronic systems. Imperix Ltd. is commercializing hardware and software solutions related to the fast and secure implementation of pilot systems and plants in the field of power conversion, energy storage and smart grids.

NOTE

While every effort has been made to ensure accuracy in this publication, no responsibility can be accepted for errors or omissions. Data may change, as well as legislation, and the reader is strongly advised to obtain copies of the most recently issued regulations, standards, and guidelines. This publication is not intended to form the basis of a contract. Copyright 2019. All rights reserved.