

A

B

C

D

A

B

C

D

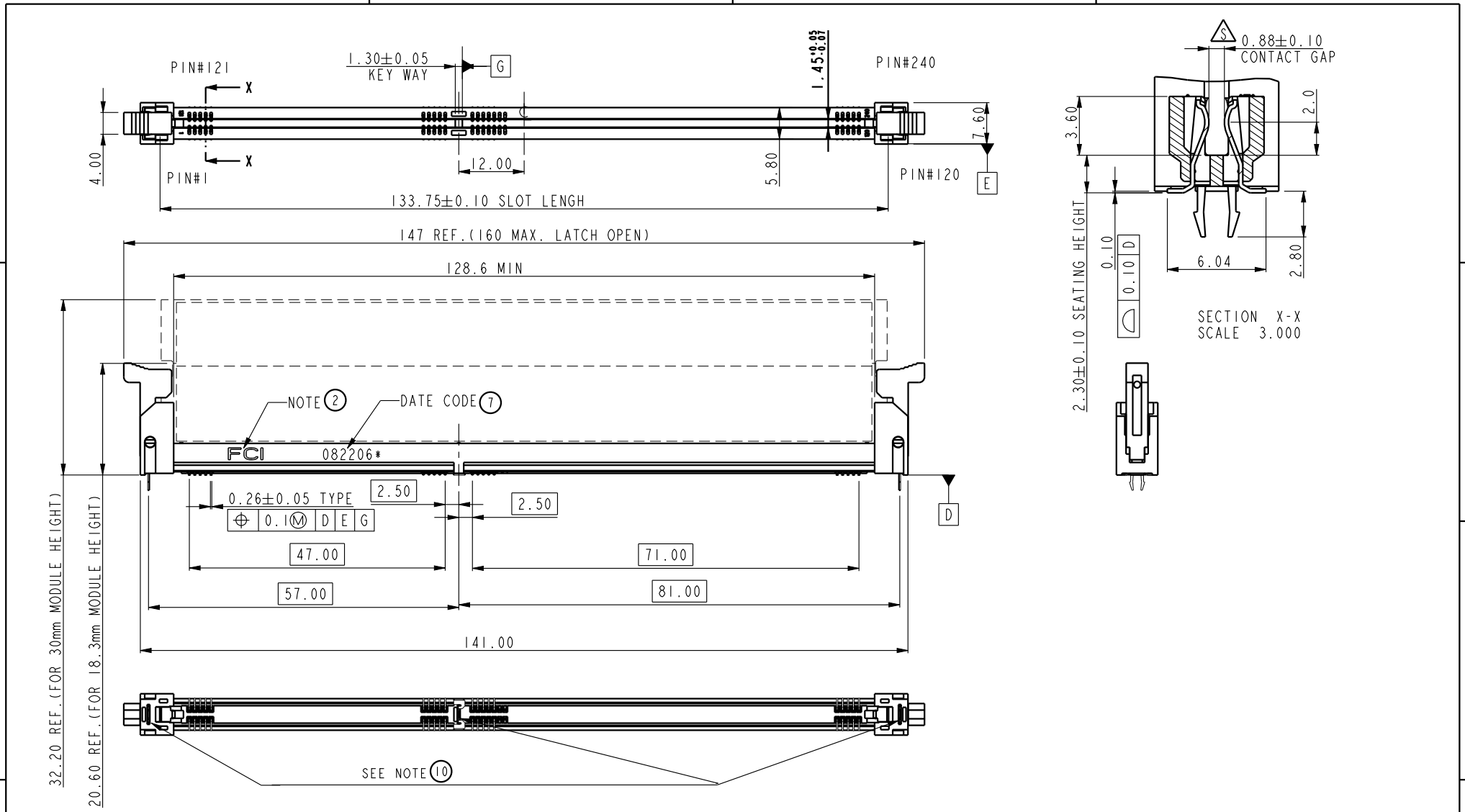

spec ref	*	dr	Rick Bian	2010/07/04	projection	MM	size	A4	scale	1.000	
tolerance std	ASME Y14.5	eng	Jeny Ren	2018/02/08				ecn no	ELX-DG-28885-1		
TOLERANCES UNLESS OTHERWISE SPECIFIED		chr	-	-				product family	rel level	Released	
surface		appr	Nickor Zuo	2018/02/09			10074146		rev	S	
ASME Y14.5		linear			SMT DDRIII SOCKET ASS'Y						
	angular			DDRIII, 240P RDIMM SOCKET (FOR CISCO)							
		www.fci.com		cat. no.	Product - Customer Drw		sheet 1 of 4				

A

B

C

D

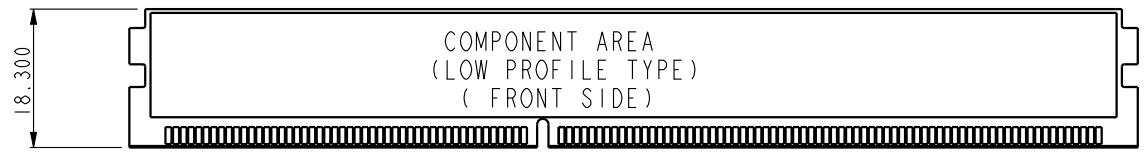
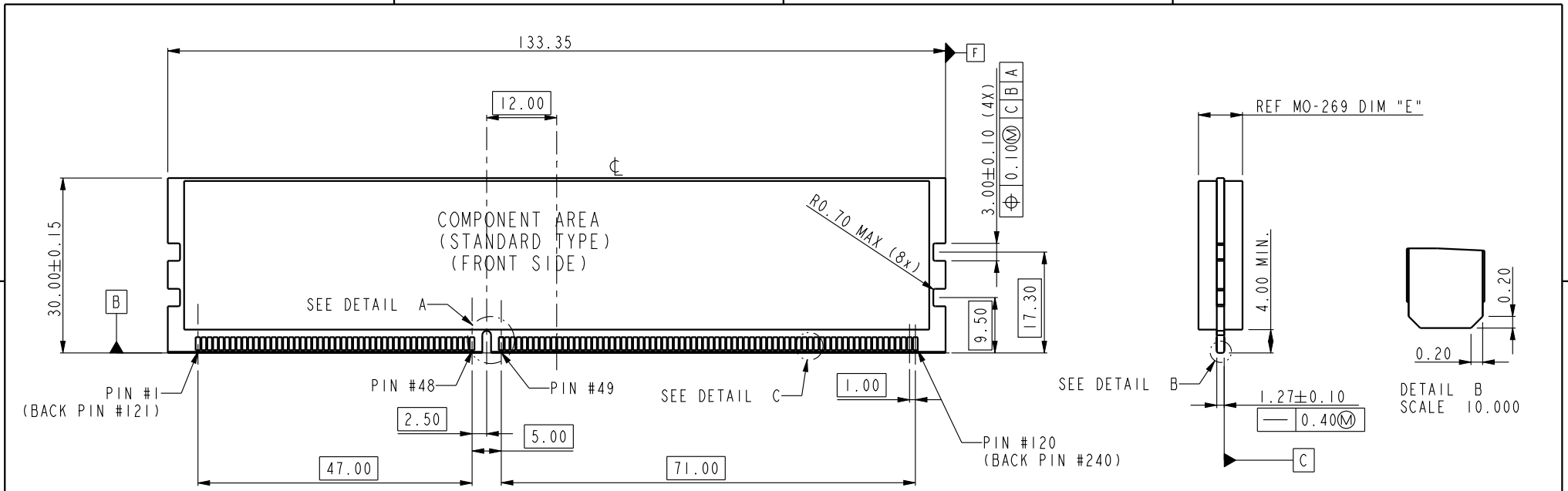

SEE MO-269 FOR DETAIL (VARIATION DX, EX, FX)

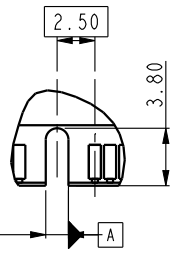
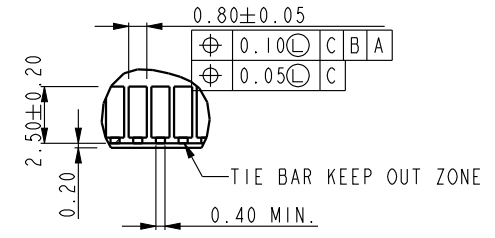

dr	Rick Bian	2010/07/04	projection	MM	size	A4	scale	1.000
eng	Jeny Ren	2018/02/08			ecn no	ELX-DG-28885-1		
chr	-	-			rel level	Released		
appr	Nickor Zuo	2018/02/09	product family	Amphenol FCI		title	SMT DDRIII SOCKET ASS'Y	
www.fci.com			cat. no.	*	Product - Customer Drw	dwg no	10074146	rev
							sheet 2 of 4	S

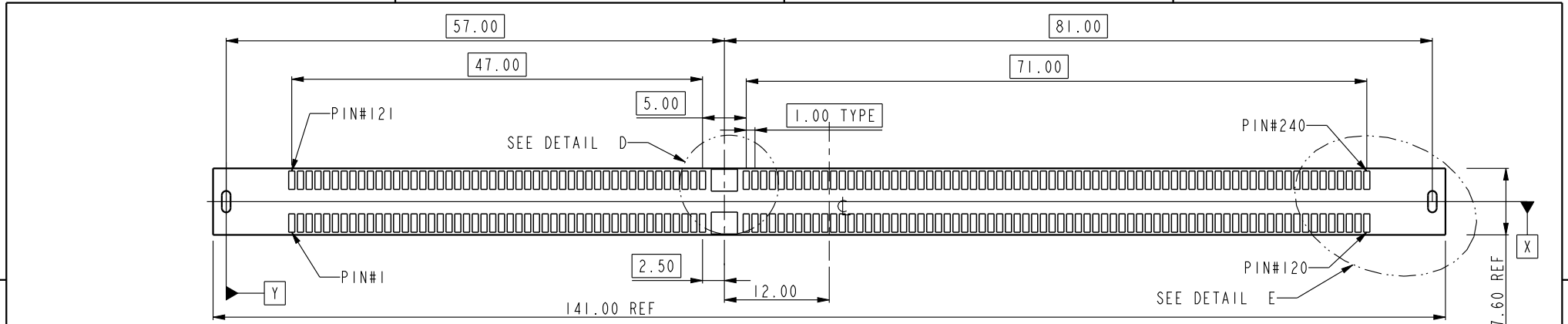

RECOMMEND CIRCUIT BOARD LAYOUT

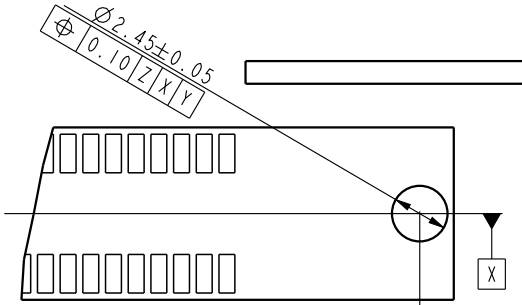

DETAIL E
SCALE 3.000
standard hole for
hold-down clips.

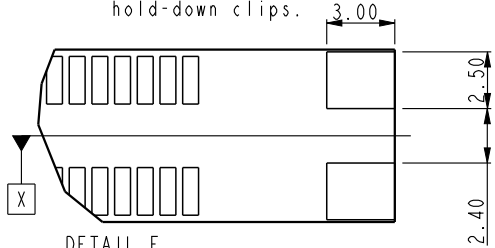

DETAIL E
SCALE 3.000
For smt holddown type.

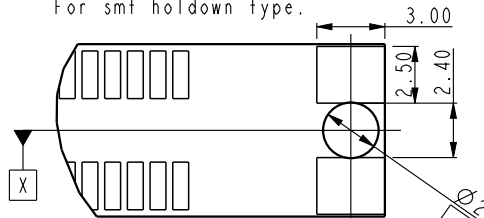

DETAIL E
SCALE 3.000

For 3 smt holddown + 2 plastic post type.

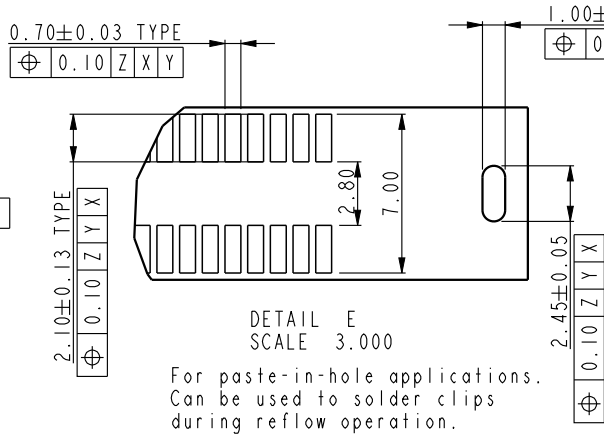

DETAIL E
SCALE 3.000
For paste-in-hole applications.
Can be used to solder clips
during reflow operation.

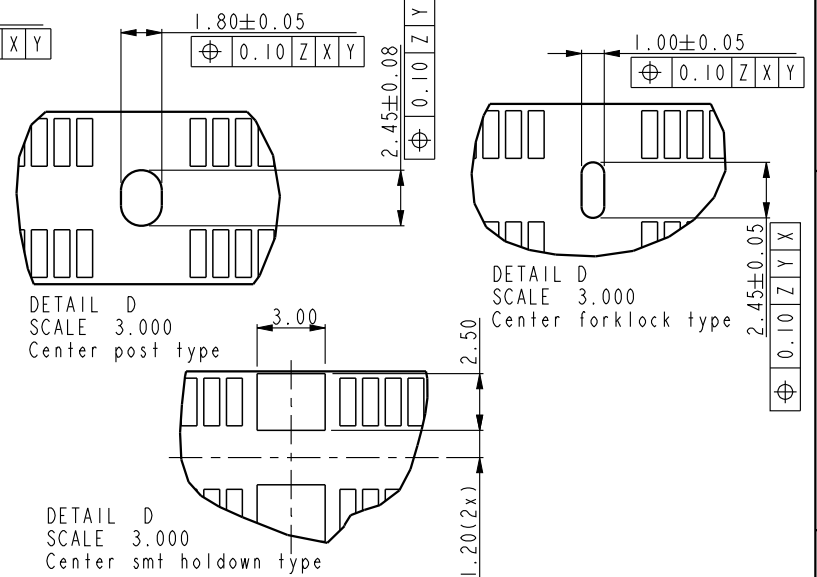

DETAIL D
SCALE 3.000
Center post type

DETAIL D
SCALE 3.000
Center smt holddown type

dr	Rick Bian	2010/07/04	projection 	MM 	size	A4	scale	1.000	
eng	Jeny Ren	2018/02/08			ecn no	ELX-DG-28885-1			
chr	-	-			rel level	Released			
appr	Nickor Zuo	2018/02/09	product family		rev				
Amphenol FCI			title			SMT DDRIII SOCKET ASS'Y		dwg no	10074146
www.fci.com			cat. no.			Product - Customer Drw		sheet 3 of 4	
			title			DDRIII, 240P RDIMM SOCKET(FOR CISCO)		rev	S

A

B

C

D

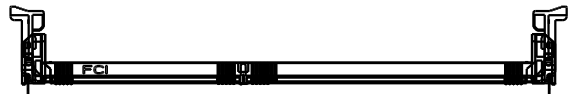

SCALE 0.500
10074146-10***
CENTER SMT HOLDOWN TYPE



SCALE 0.500
10074146-11***
3 FORKLOCK TYPE

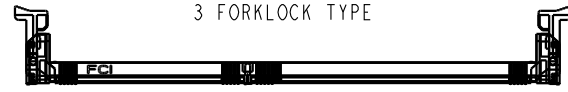

SCALE 0.500
10074146-12***
3 SMT HOLDOWN TYPE



SCALE 0.500
10074146-13*** SEE DETAIL N
3 SMT HOLDOWN AND 2 PLASTIC POST TYPE

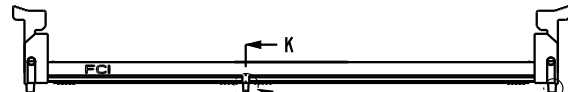

SCALE 0.500
10074146-15*** SEE DETAIL M
3 PLASTIC POST TYPE

NOTES:

- MATERIAL:
HOUSING: HIGH PERFORMANCE RESINS, GLASS FILLED UL94V-0 RATED.
EJECTOR: HIGH PERFORMANCE RESINS, GLASS FILLED UL94V-0 RATED.
TERMINAL: HIGH PERFORMANCE COPPER ALLOY
METAL CLIP: COPPER ALLOY.
- FCI LOGO TO BE APPROXIMATELY LOCATED AS SHOWN ON PRINT.
- PRODUCT SPECIFICATION: GS-12-481.
- PACKAGING SPECIFICATION: GS-14-899.
- RECOMMENDED STENCIL THICKNESS NO LESS THAN 0.15 mm.
- FOR OPTUM PERFORMANCE, THE TIE BAR IS TO BE ON AN INTERNAL LAYER SO THAT THE REMNANT CANNOT CAUSE CONTACT DAMAGE.
- THE DATE CODE IS SHOWN "MMDDYY*.". "*" MEANS PRODUCTION LINE.
- THIS PRODUCT MEETS EUROPEAN UNION DIRECTIVES AND OTHER COUNTRY REGULATIONS AS DESCRIBED IN GS-22-008.
- THE HOUSING WILL WITH STAND EXPOSURE TO 260°C PEAK TEMPERATURE FOR 10 SECONDS IN AN IR REFLOW SOLDERING APPLICATION.
- THE HOLDOWN TYPES ARE OPTION FOR FORKLOCK OR SMT HOLDOWN.
- A Δ SYMBOL WILL BE NEXT TO ANY DIMENSION, VIEW, OR NOTE WHICH HAS BEEN MODIFIED WITH THE CURRENT DRAWING REVISION

STYLE : MECHANICAL KEYING

1 : 1.5 VOLT. W/ CENTER KEY

HOLD DOWN TYPE

- 0 : CENTER HOLD DOWN, FORKLOCK AT BOTH END
1 : 3 FORKLOCK TYPE
2 : 3 SMT HOLDOWN TYPE
3 : 3 SMT HOLDOWN AND 2 PLASTIC POST
5 : 3 PLASTIC POST TYPE

PACKAGE AND MYLAR OPTION

- 0: SOFT TRAY WITHOUT MYLAR (OBSOLETE)
1: HARD TRAY WITH MYLAR
2: HARD TRAY WITHOUT MYLAR
3: SOFT TRAY WITH MYLAR (OBSOLETE)

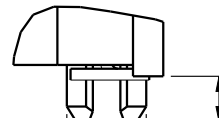

DETAIL N
SCALE 5.000

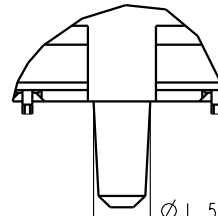

DETAIL J
SCALE 5.000

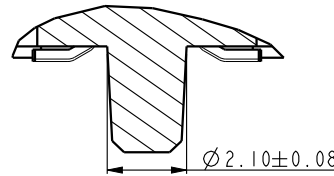

SECTION K-K
SCALE 5.000

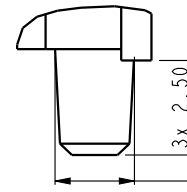

DETAIL M
SCALE 5.000

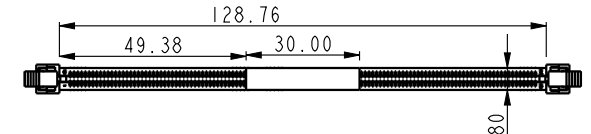

SCALE 0.500
WITH MYLAR TAPE (OPTIONAL)

10074146 - □ □ □ □ □

PLATING

CODE	CONTACT	SOLDERTAIL	UNDERPLATE	NOTE
1	10u" (0.25um) MIN. GOLD	100u" (2.54um) TIN-LEAD	50u" (1.27um) MIN. NICKEL OVERALL	CONTACT NON-LUBRICATED
2	15u" (0.38um) MIN. GOLD			
3	30u" (0.76um) MIN. GOLD			
4	GOLD FLASH			CONTACT LUBRICATED
5	10u" (0.25um) MIN. GOLD			
6	15u" (0.38um) MIN. GOLD	100u" (2.54um) MIN. 100% MATT TIN	50u" (1.27um) MIN. NICKEL OVERALL	CONTACT NON-LUBRICATED
7	30u" (0.76um) MIN. GOLD			
8	GOLD FLASH			
1LF	10u" (0.25um) MIN. GOLD	100u" (2.54um) MIN. 100% MATT TIN	50u" (1.27um) MIN. NICKEL OVERALL	CONTACT NON-LUBRICATED
2LF	15u" (0.38um) MIN. GOLD			
3LF	30u" (0.76um) MIN. GOLD			
4LF	GOLD FLASH			
5LF	10u" (0.25um) MIN. GOLD			CONTACT LUBRICATED
6LF	15u" (0.38um) MIN. GOLD			
7LF	30u" (0.76um) MIN. GOLD			
8LF	GOLD FLASH			

COLOR OF HOUSING AND EJECTOR

- 0 : BLACK HOUSING + IVORY EJECTOR
1 : BLACK HOUSING + BLACK EJECTOR
2 : BLACK HOUSING + BLUE(661C) EJECTOR
3 : BLACK HOUSING + YELLOW(123C) EJECTOR

dr	Rick Bian	2010/07/04	projection	MM	size	A4	scale	1.000
eng	Jeny Ren	2018/02/08			ecn no ELX-DG-28885-1			
chr	-	-			rel level Released			
appr	Nickor Zuo	2018/02/09	product family		rev			
Amphenol FCI		SMT DDRIII SOCKET ASS'Y			dwg no		10074146	
www.fci.com		DDRIII, 240P RDIMM SOCKET(FOR CISCO)			sheet 4 of 4		S	
cat. no.		Product - Customer Drw			sheet 4 of 4			