

PART NAME	UTILIBOX (STYLE E)	PART No.	CU-793 & CUR-793
-----------	--------------------	----------	------------------

**MATERIAL:**

ABS THERMOPLASTIC  
 (FLAMMABILITY RATING OF 94V-0 AT  
 0.070" THICKNESS AND CONTINUOUS  
 USE TEMPERATURE OF 70° C.)

**FINISH:**

BODY (NO SUFFIX) - OUTSIDE SURFACES ARE TEXTURED FINISH WITH TEXTURED INSERT AREA.  
 BODY (SUFFIX -R) - OUTSIDE SURFACES ARE TEXTURED FINISH WITH SMOOTH RECESSED INSERT AREA.  
 COVER - SURFACES ARE SMOOTH.

**COLOR:** BLACK

COVER REDUCES INSIDE HEIGHT BY 0.085.

LENGTH AND WIDTH DIMENSIONS ARE TAKEN FROM CLOSED END OF THE BOX. DIMENSIONS INCREASE SLIGHTLY AT OPEN END DUE TO TAPER.

FOUR (4) #4 x 0.500" LG. SELF THREADING SCREWS WITH HI/LOW THREADS ARE SUPPLIED FOR MOUNTING COVER.

**NOTE:** ALL DIMENSIONS HAVE ±0.010 TOLERANCE UNLESS OTHERWISE SPECIFIED.

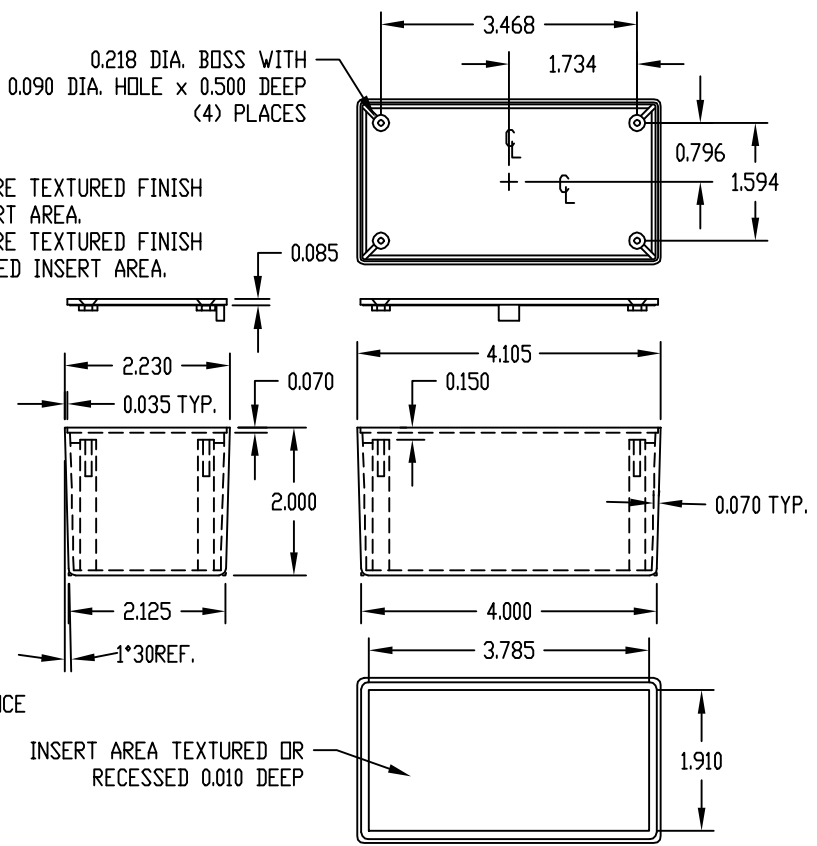

PART NAME	UTILIBOX (STYLE E)	PART No.	CU-793-MB & CUR-793-MB
-----------	--------------------	----------	------------------------

**MATERIAL:**

ABS THERMOPLASTIC  
 (FLAMMABILITY RATING OF 94V-0 AT  
 0.070" THICKNESS AND CONTINUOUS  
 USE TEMPERATURE OF 70° C.)

**FINISH:**

BODY (SUFFIX -MB) - OUTSIDE SURFACES ARE TEXTURED FINISH WITH TEXTURED INSERT AREA.  
 BODY (SUFFIX -RMB) - OUTSIDE SURFACES ARE TEXTURED FINISH WITH SMOOTH RECESSED INSERT AREA.  
 COVER - SURFACES ARE SMOOTH.

**COLOR:** BLACK

COVER REDUCES INSIDE HEIGHT BY 0.085.

LENGTH AND WIDTH DIMENSIONS ARE TAKEN FROM CLOSED END OF THE BOX. DIMENSIONS INCREASE SLIGHTLY AT OPEN END DUE TO TAPER.

FOUR (4) #4 x 0.500" LG. SELF THREADING SCREWS WITH HI/LOW THREADS ARE SUPPLIED FOR MOUNTING COVER.

**NOTE:** ALL DIMENSIONS HAVE ±0.010 TOLERANCE UNLESS OTHERWISE SPECIFIED.

