

PART NUMBER	REVISION	DESCRIPTION	FEED TYPE
2266451-2	F	FINE CRIMP HEIGHT ADJUST	PNEUMATIC
7-2266451-2	F	PNEUMATIC AND CRIMP TOOLING KIT	PNEUMATIC
7-2266451-7	E	CRIMP TOOLING KIT	-

ATLANTIC VERSION TERMINATOR INTERFACE ADAPTER

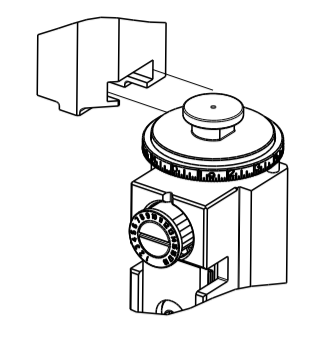

APPLICATOR DATA		
CRIMP	SIZE	TYPE
WIRE	2.54 mm [.100]	F
INSUL	3.05 mm [.120]	OV

APPLICATOR INSTRUCTIONS 408-35042

TERMINAL DATA: YAZAKI TERMINAL YAZAKI CRIMP SPECIFICATION			
TERMINAL NAME: 6.3 SYSTEM CONNECTOR FEMALE			
WIRE STRIP LENGTH		INSULATION DIAMETER RANGE	
5.00-5.50 mm [.197-.217 IN]		Ø1.40-2.20 mm [.055-.087 IN]	
TERMINAL APPLICATION SPECIFICATION	YAZAKI SPEC Rev -	-	-
TERMINALS APPLIED			
TE TERMINAL	YAZAKI TERMINAL	TE TERMINAL	YAZAKI TERMINAL
2113144-1	7116-4120-02	1949028-1	7114-4120-02

WIRE SIZE	CRIMP HEIGHT mm [INCH]	CRIMP HEIGHT REFERENCE SETTING
1.25mm2	1.40 +/- 0.05 [0.055 +/- .002]	3.9
0.75mm2	1.30 +/- 0.05 [0.051 +/- .002]	5.0
0.50mm2	1.25 +/- 0.05 [0.049 +/- .002]	5.3

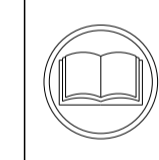

- 1 RECOMMENDED SPARE PARTS
- 2 REFER TO SUPPLIED INSTRUCTION SHEET FOR CLEANING, LUBRICATION AND STORAGE OF APPLICATOR.
- 3 APPLY PART NUMBER 2-23419-6 LOCTITE TO THREADS OF ITEM 242.
- 4 CRIMP HEIGHT REFERENCE SETTING WAS THE SETTING USED WHEN THE APPLICATOR WAS QUALIFIED AT THE FACTORY. ADJUSTMENT MAY BE NECESSARY WHEN RUNNING APPLICATOR IN THE FIELD.
- 5 TERMINAL PITCH NOT COMPATIBLE WITH MECHANICAL FEED.
- 6. UNLESS SPECIFIED OTHERWISE TORQUE VALUES SHALL BE USED PER DOCUMENT, 101-35000.

***WARNING**
 ON INSTALLATION, SET WIRE DISC TO CRIMP HEIGHT REFERENCE SETTING FOR LARGEST WIRE SIZE. CRIMP HEIGHT REFERENCE SETTINGS GREATER THAN THE VALUE SHOWN MAY CAUSE DAMAGE TO THE CRIMP TOOLING. REFER TO THE INSTRUCTION SHEET FOR PROPER SETUP AND ADJUSTMENTS.

ATLANTIC VERSION
 Shown on sheets 1 of 4 & 2 of 4
 (Pacific version shown on sheets 3 of 4 & 4 of 4)

LOC	DIST	REVISIONS					
A	66	P	LTN	DESCRIPTION	DATE	OWN	APVD
		D		ECR-20-006183	29APR2020	JWC	GB
		E		ECR-20-016764	25NOV2020	FZ	TE
		E1		ECR-21-007004	22JUL2021	JWC	TE
		F		ECR-21-112993	07SEP2021	JWC	RK

-	1	1	2119641-1	FEED CAM, AIR FEED	248
-	1	1	2119082-4	CAM, SNAIL, INSULATION ADJUSTMENT	244
-	1	1	2079764-1	WASHER, WAVE SPRING, CREST-TO-CREST	243
-	1	1	2119083-1	RETAINER, INSULATION DIAL	242
-	1	1	7-18023-7	SCR, SKT HD CAP M3 X 4.0	241
-	1	1	2844940-2	AIR FEED MODULE	238
-	REF	REF	994970-2	COUNTER, MAGNETIC	164
-	1	1	2844908-1	SCREW, LOCKING	99
-	1	1	2844907-1	POST, LOCKING	98
-	1	1	455888-6	SPACER, CRIMPER	82
-	2	2	2079383-4	SCR, BHSC, RoHS (M4 X 8)	79
-	1	1	1803096-1	EXTENSION PLATE	78
-	1	1	1803607-3	DOCUMENTATION PACKAGE	71
-	1	1	2119740-1	TAG, IDENTIFICATION	67
-	2	2	2168078-1	SCREW, DRIVE, RH, RoHS, 2 x .188	66
-	1	1	2168083-2	SCR, SKT HD CAP, RoHS, M4 X 8.0	60
-	1	1	5-18022-5	SCR, HEX HD CAP, M4 X 6.0	59
-	1	1	1338685-1	PAWL, FEED	56
-	4	4	2168083-3	SCR, SKT HD CAP, RoHS, M4 X 12.0	54
-	2	2	2-2168083-5	SCR, SKT HD CAP, RoHS, M4 X 14	53
-	1	1	1803382-6	HOLD DOWN, SPRING LOADED	50
-	1	1	18023-9	SCR, SKT HD CAP M4 X 6.0	49
-	1	1	1803583-9	APPLICATOR BASIC ASSEMBLY, SF	46
-	1	1	1803515-1	RAM ASSEMBLY, SF ATLANTIC	44
-	1	1	1803602-1	SCR, BHSC, RoHS (M8 X 25)	41
-	1	1	1752356-1	SUPPORT, TERMINAL	34
-	2	2	2079383-5	SCR, BHSC, RoHS (M4 X 20)	33
-	2	2	2-2844962-0	SPACER, CYLINDRICAL, STRIP GUIDE	30
-	1	1	2844992-2	ASSEMBLY, STRIP GUIDE	29
-	1	1	455888-3	SPACER, CRIMPER	28
-	1	1	1320928-4	STRIP GUIDE	24
-	1	1	2168083-2	SCR, SKT HD CAP, RoHS, M4 X 8.0	21
-	2	2	1-18028-2	WASHER, FLAT, REG M4	20
-	1	1	2119533-1	STRIPPER, SIDE FEED	19
-	1	1	2119806-1	INSERT, SHEAR	13
-	1	1	3-22280-3	SPRING, COMPRESSION	12
-	1	1	1-356885-4	STOP, SHEAR	11
-	1	1	2119805-1	SHEAR HOLDER, FRONT	10
-	1	1	454276-5	FLOATING SHEAR, FRONT	9
1	2	1	2-1633922-1	ANVIL, COMBINATION	8
-	1	1	3-240641-1	SPACER	7
-	-	-	-	-	6
-	1	1	2119757-8	DEPRESSOR, SHEAR	5
-	1	1	2-238011-1	BLOCK, CRIMPER SPACER	4
1	2	1	6-1633964-4	CRIMPER, INSULATION OVERLAP PREMIUM	3
-	1	1	455888-5	SPACER, CRIMPER	2
1	2	1	3-456407-3	CRIMPER, WIRE PREMIUM	1
-	77	-72	-2	PART NO	ITEM NO

DIMENSIONS: mm 		TOLERANCES UNLESS OTHERWISE SPECIFIED: 0 PLC ± 1 PLC ± 2 PLC ± 3 PLC ± 4 PLC ± ANGLES ± FINISH ±		DWG J.HOU 30JULY2014 CHK Y.YIN 30JULY2014 APVD U.GUO 30JULY2014		NAME Ocean Side Feed Applicator SIZE CAGE CODE DRAWING NO RESTRICTED TO A1 00779 C=2266451 -	
MATERIAL		FINISH		WEIGHT		SCALE 1:2 SHEET 1 OF 4 REV F	

LOC	DIST	REVISIONS			
P	LTN	DESCRIPTION	DATE	OWN	APVD
A	66	SEE SHEET 1	-	-	-

FEED TYPE

PNEUMATIC

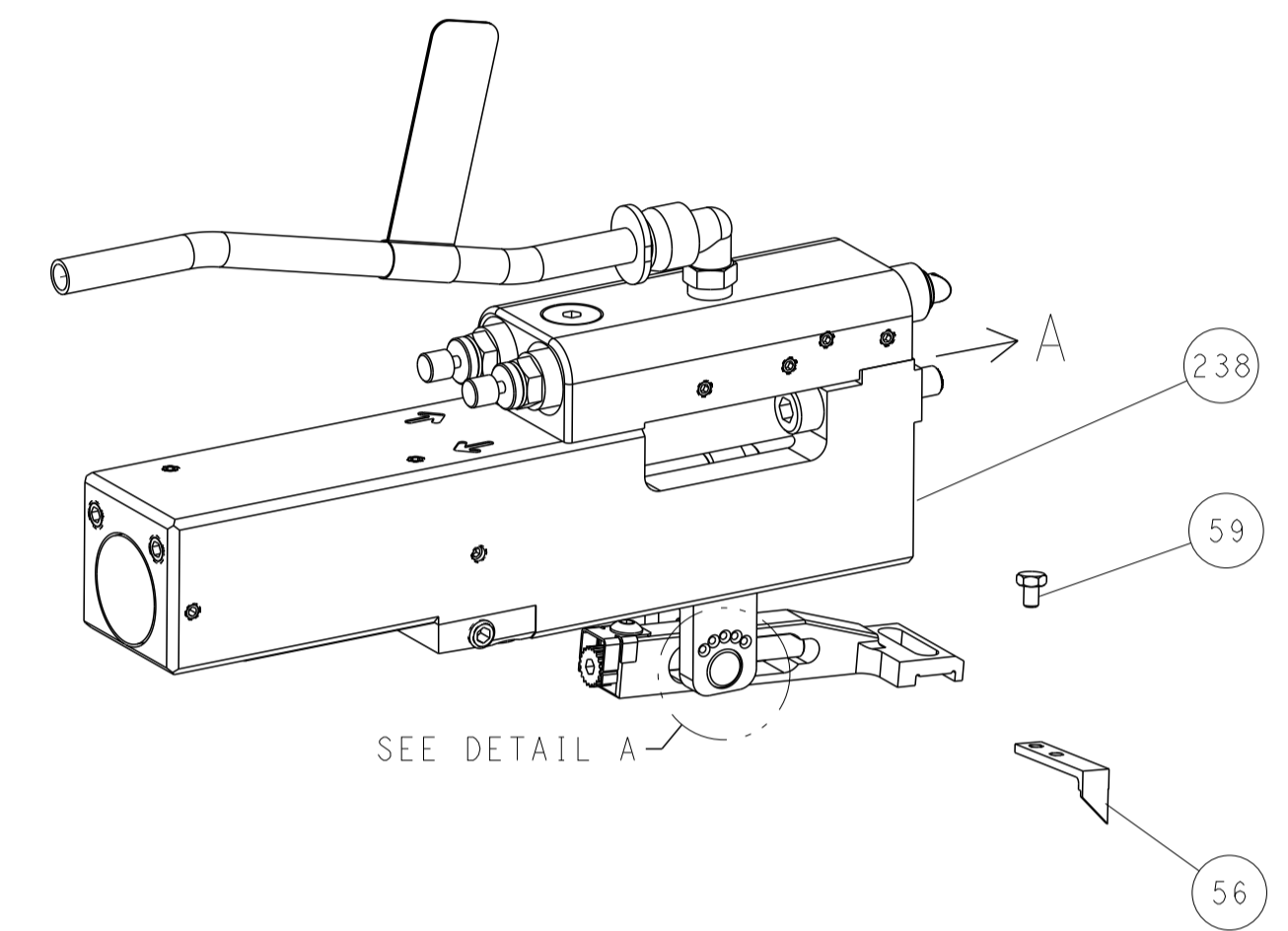

FEED SPRING SETTING POSITION (SHOWN FROM REAR SIDE)

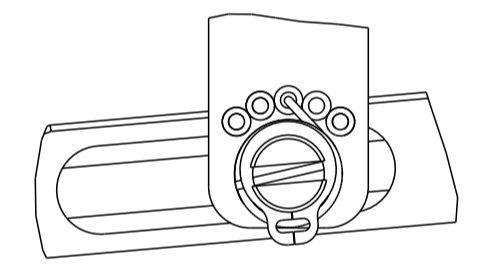

DETAIL A

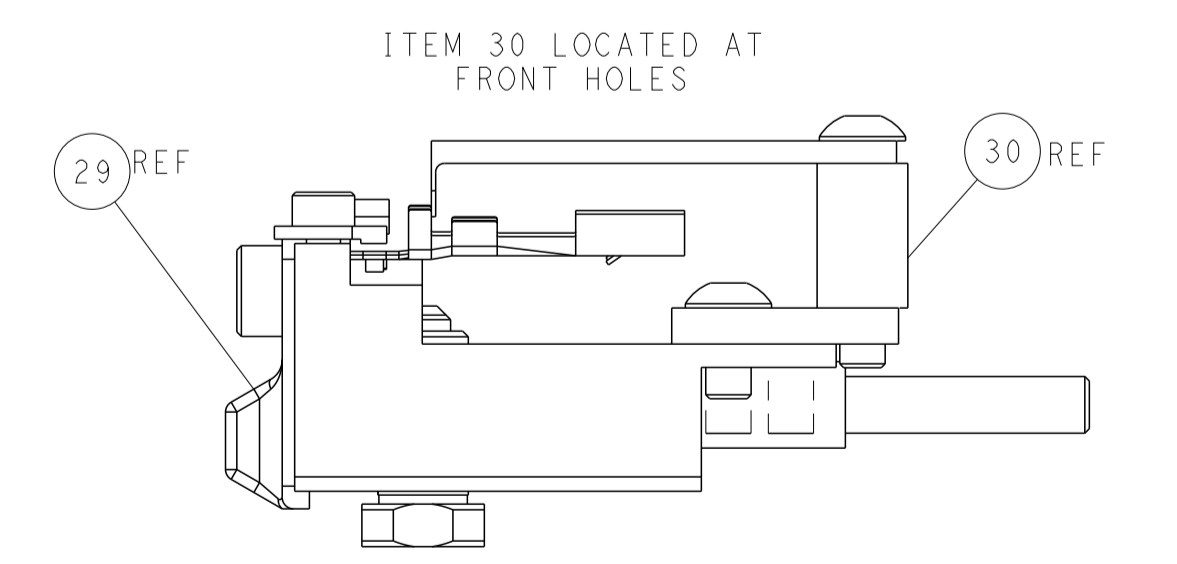
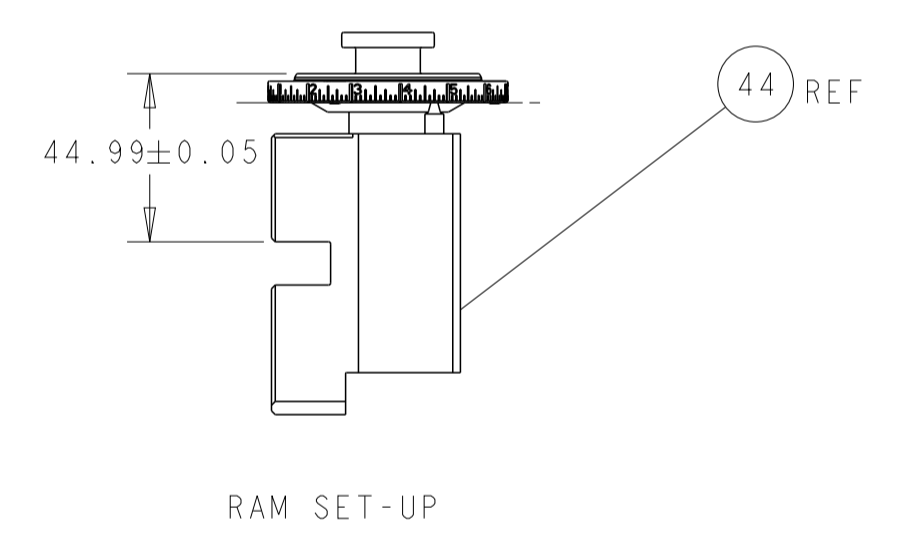
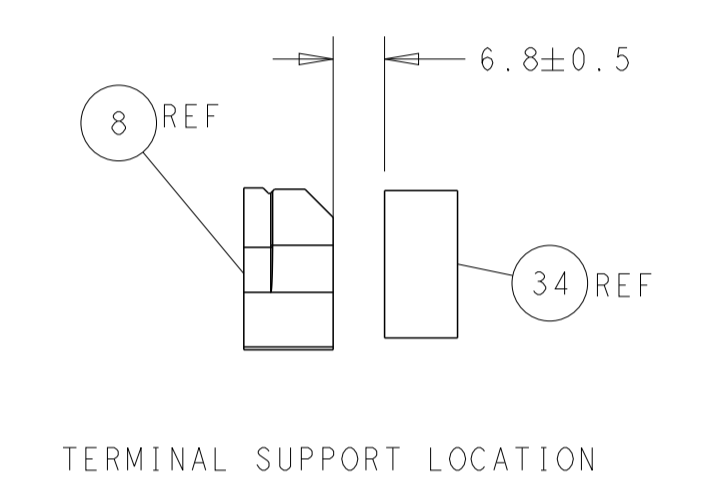
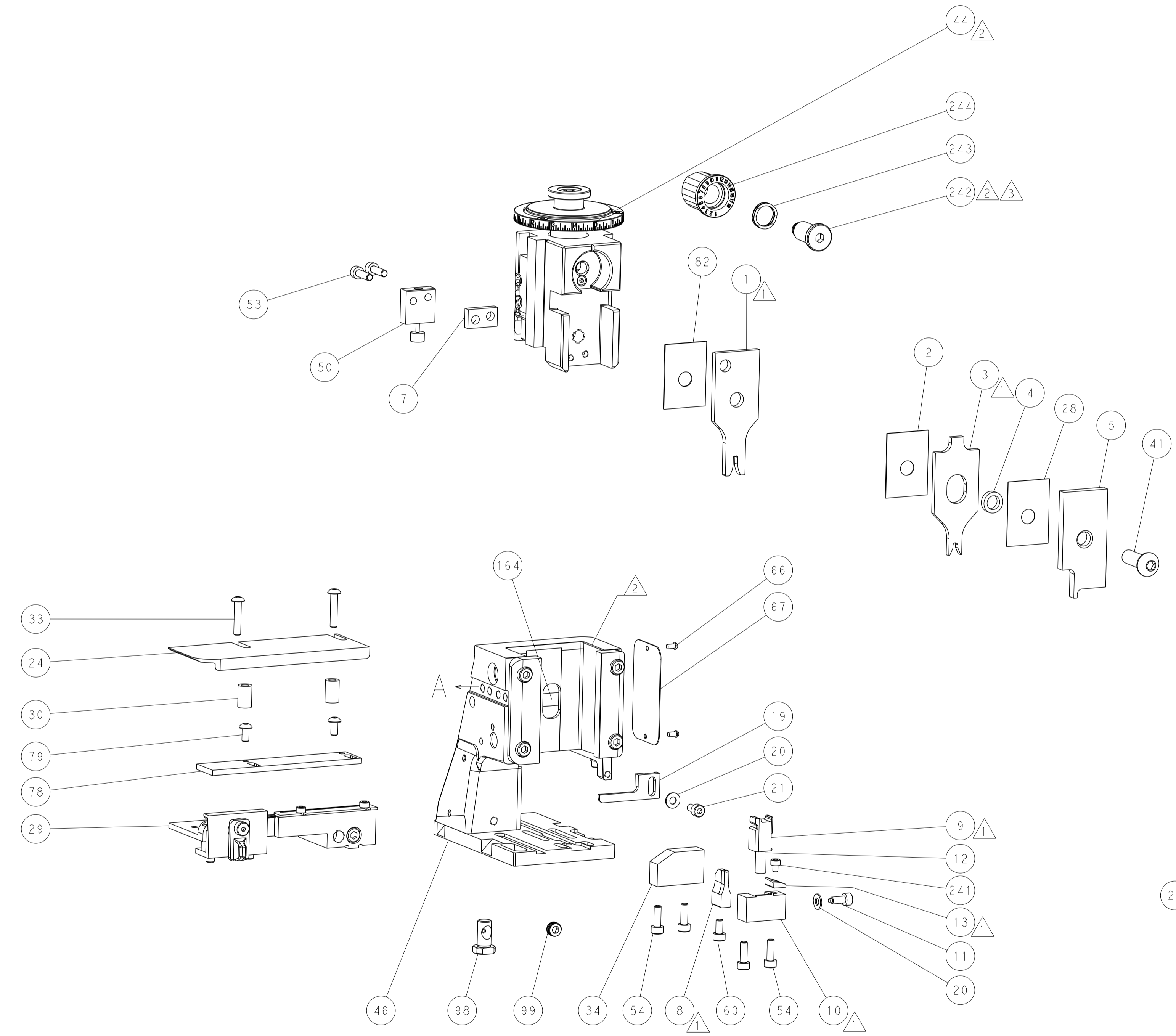

CAM POSITION

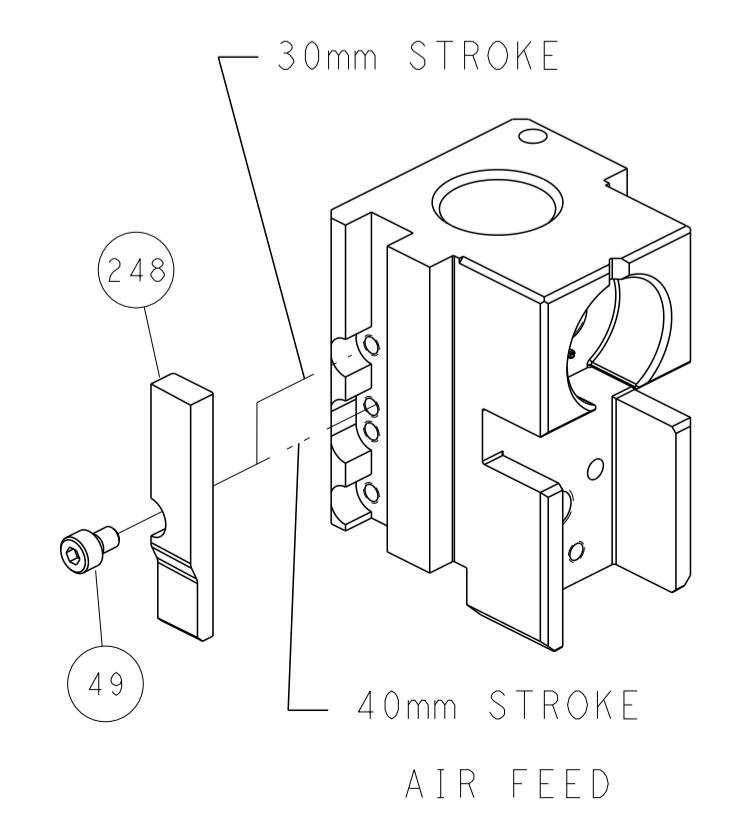

ATLANTIC VERSION
 Shown on sheets 1 of 4 & 2 of 4
 (Pacific version shown on sheets 3 of 4 & 4 of 4)

<small>THIS DRAWING IS UNPUBLISHED. RELEASED FOR PUBLICATION. ALL RIGHTS RESERVED. THIS DRAWING IS CONTROLLED DOCUMENT. THIS DRAWING IS THE PROPERTY OF TYCO ELECTRONICS CORPORATION. IT IS TO BE USED ONLY FOR THE PURPOSES AND IN THE MANNER SPECIFIED BY THE DRAWING. IT IS TO BE KEPT IN THE ORIGINAL OR IN A COPY. IT IS TO BE DESTROYED WHEN NO LONGER REQUIRED FOR THE LATEST REVISION.</small>		DWN J.HOU 30JULY2014 CHK Y.YIN 30JULY2014 APVD H.GUO 30JULY2014	NAME Ocean Side Feed Applicator SIZE A1 CAGE CODE 00779 DRAWING NO. C=2266451 RESTRICTED TO F
DIMENSIONS: mm TOLERANCES UNLESS OTHERWISE SPECIFIED: 0 PLC ± 1 PLC ± 2 PLC ± 3 PLC ± 4 PLC ± ANGLES ± FINISH	WEIGHT SCALE 1:2 SHEET 2 OF 4 REV F	TE Connectivity Harrisburg, PA 17105-3608	Customer Accessible Production Drawing

PART NUMBER	REVISION	DESCRIPTION	FEED TYPE
2-2266451-2	F	FINE CRIMP HEIGHT ADJUST	PNEUMATIC
7-2266451-7	E	CRIMP TOOLING KIT	-

PACIFIC VERSION TERMINATOR
INTERFACE ADAPTER



APPLICATOR DATA		
CRIMP	SIZE	TYPE
WIRE	2.54 mm [.100]	F
INSUL	3.05 mm [.120]	OV
APPLICATOR INSTRUCTIONS 408-35042		

TERMINAL DATA: YAZAKI TERMINAL YAZAKI CRIMP SPECIFICATION	
TERMINAL NAME: 6.3 SYSTEM CONNECTOR FEMALE	
WIRE STRIP LENGTH 5.00-5.50 mm [.197-.217 IN]	INSULATION DIAMETER RANGE Ø1.40-2.20 mm [.055-.087 IN]
TERMINAL APPLICATION SPECIFICATION YAZAKI SPEC Rev -	
TERMINALS APPLIED	
TE TERMINAL 2113144-1	YAZAKI TERMINAL 7116-4120-02
TE TERMINAL 1949028-1	YAZAKI TERMINAL 7114-4120-02

WIRE SIZE	CRIMP HEIGHT mm [INCH]	CRIMP HEIGHT REFERENCE SETTING
1.25mm2	1.40 +/- 0.05 [.055 +/- .002]	3.9
0.75mm2	1.30 +/- 0.05 [.051 +/- .002]	5.0
0.50mm2	1.25 +/- 0.05 [.049 +/- .002]	5.3



- 1 RECOMMENDED SPARE PARTS
- 2 REFER TO SUPPLIED INSTRUCTION SHEET FOR CLEANING, LUBRICATION AND STORAGE OF APPLICATOR.
- 3 APPLY PART NUMBER 2-23419-6 LOCTITE TO THREADS OF ITEM 242.
- 4 CRIMP HEIGHT REFERENCE SETTING WAS THE SETTING USED WHEN THE APPLICATOR WAS QUALIFIED AT THE FACTORY. ADJUSTMENT MAY BE NECESSARY WHEN RUNNING APPLICATOR IN THE FIELD.
- 5 TERMINAL PITCH NOT COMPATIBLE WITH MECHANICAL FEED.
- 6. UNLESS SPECIFIED OTHERWISE TORQUE VALUES SHALL BE USED PER DOCUMENT, 101-35000.

***WARNING**
ON INSTALLATION, SET WIRE DISC TO CRIMP HEIGHT REFERENCE SETTING FOR LARGEST WIRE SIZE. CRIMP HEIGHT REFERENCE SETTINGS GREATER THAN THE VALUE SHOWN MAY CAUSE DAMAGE TO THE CRIMP TOOLING, REFER TO THE INSTRUCTION SHEET FOR PROPER SETUP AND ADJUSTMENTS.

PACIFIC VERSION
Shown on sheets 3 of 4 & 4 of 4
(Atlantic version shown on sheets 1 of 4 & 2 of 4)

LOC	DIST	REVISIONS					
A	66	P	LTN	DESCRIPTION	DATE	DWN	APVD
-	-	-	-	SEE SHEET 1	-	-	-

-	1	2119082-4	CAM, SNAIL, INSULATION ADJUSTMENT	244	
-	1	2079764-1	WASHER, WAVE SPRING, CREST-TO-CREST	243	
-	1	2119083-1	RETAINER, INSULATION DIAL	242	
-	1	7-18023-7	SCR, SKT HD CAP M3 X 4.0	241	
-	1	2844940-2	AIR FEED MODULE	238	
-	REF	994970-2	COUNTER, MAGNETIC	164	
-	1	2119641-2	FEED CAM, AIR FEED	151	
-	1	2168083-8	SCR, SKT HD CAP, RoHS, M4 X 16	144	
-	4	2168083-9	SCR, SKT HD CAP, RoHS, M4 X 20	143	
-	-	2119653-2	FEED CAM, POST FEED	142	
-	1	1-1803583-0	APPLICATOR BASIC ASSEMBLY, SF	141	
-	1	1803516-1	RAM ASSEMBLY, SF PACIFIC	140	
-	1	2844908-1	SCREW, LOCKING	99	
-	1	2844907-1	POST, LOCKING	98	
-	1	455888-6	SPACER, CRIMPER	82	
-	2	2079383-4	SCR, BHSC, RoHS (M4 X 8)	79	
-	1	1803096-1	EXTENSION PLATE	78	
-	1	1803607-3	DOCUMENTATION PACKAGE	71	
-	1	2119740-1	TAG, IDENTIFICATION	67	
-	2	2168078-1	SCREW, DRIVE, RH, RoHS, 2 x .188	66	
-	1	5-18022-5	SCR, HEX HD CAP, M4 X 6.0	59	
-	1	1338685-1	PAWL, FEED	56	
-	2	2-2168083-5	SCR, SKT HD CAP, RoHS, M4 X 14	53	
-	1	1803382-6	HOLD DOWN, SPRING LOADED	50	
-	1	18023-9	SCR, SKT HD CAP M4 X 6.0	49	
-	1	1803602-1	SCR, BHSC, RoHS (M8 X 25)	41	
-	1	1752356-1	SUPPORT, TERMINAL	34	
-	2	2079383-5	SCR, BHSC, RoHS (M4 X 20)	33	
-	2	2-2844962-0	SPACER, CYLINDRICAL, STRIP GUIDE	30	
-	1	2844992-2	ASSEMBLY, STRIP GUIDE	29	
-	1	455888-3	SPACER, CRIMPER	28	
-	1	1320928-4	STRIP GUIDE	24	
-	1	2168083-2	SCR, SKT HD CAP, RoHS, M4 X 8.0	21	
-	2	1-18028-2	WASHER, FLAT, REG M4	20	
-	1	2119533-1	STRIPPER, SIDE FEED	19	
-	1	2119806-1	INSERT, SHEAR	13	
-	1	3-22280-3	SPRING, COMPRESSION	12	
-	1	1-356885-4	STOP, SHEAR	11	
-	1	2119805-1	SHEAR HOLDER, FRONT	10	
-	1	454276-5	FLOATING SHEAR, FRONT	9	
-	1	2-1633922-1	ANVIL, COMBINATION	8	
-	1	3-240641-1	SPACER	7	
-	-	-	-	6	
-	1	2119757-8	DEPRESSOR, SHEAR	5	
-	1	2-238011-1	BLOCK, CRIMPER SPACER	4	
-	1	6-1633964-4	CRIMPER, INSULATION OVERLAP PREMIUM	3	
-	1	455888-5	SPACER, CRIMPER	2	
-	1	3-456407-3	CRIMPER, WIRE PREMIUM	1	
-	77	-22	PART NO	DESCRIPTION	ITEM NO

DIMENSIONS:		TOLERANCES UNLESS OTHERWISE SPECIFIED:		DWG J.HOU 30JULY2014		REV Y.YIN 30JULY2014		NAME Ocean Side Feed Applicator		RESTRICTED TO	
mm		0 PLC ± 1 PLC ± 2 PLC ± 3 PLC ± 4 PLC ± ANGLES ± FINISH		APVD J.GUO 30JULY2014		PRODUCT SPEC		SIZE A1		SCALE 1:2	
MATERIAL				WEIGHT		CAGE CODE 00779		DRAWING NO 2266451		SHEET 3 OF 4	
						Customer Accessible Production Drawing		REV F			

SHEETS 1 & 2 ARE NOT REQUIRED FOR PACIFIC VERSION

LOC	DIST	REVISIONS			
P	LTN	DESCRIPTION	DATE	OWN	APVD
-	-	SEE SHEET 1	-	-	-

FEED TYPE

PNEUMATIC

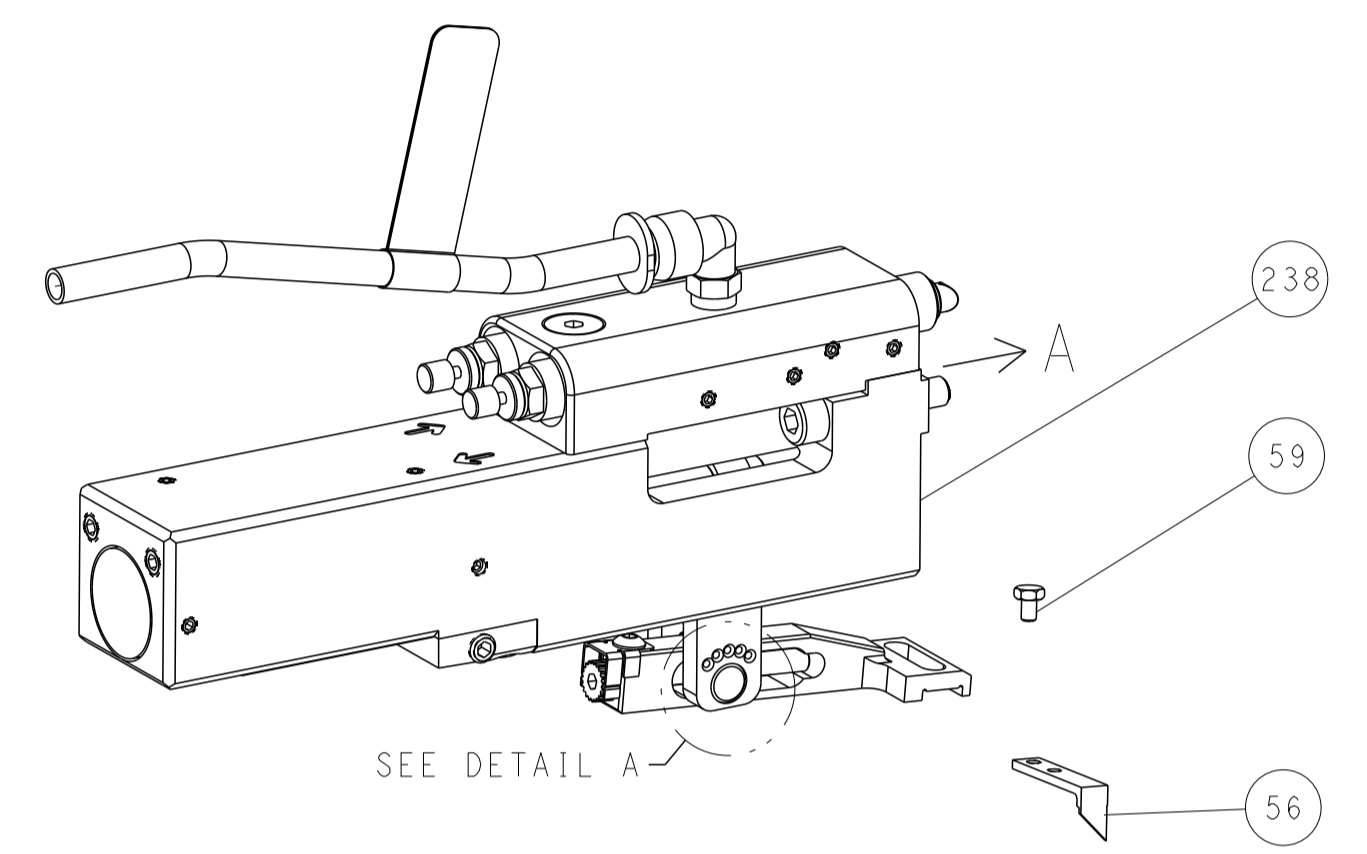

SEE DETAIL A

FEED SPRING SETTING POSITION (SHOWN FROM REAR SIDE)

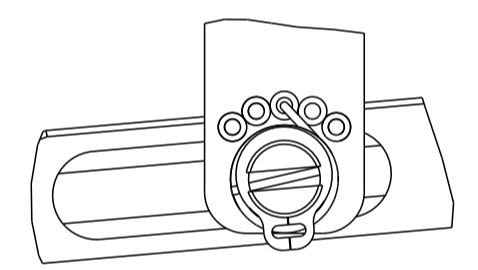

DETAIL A

CAM POSITION

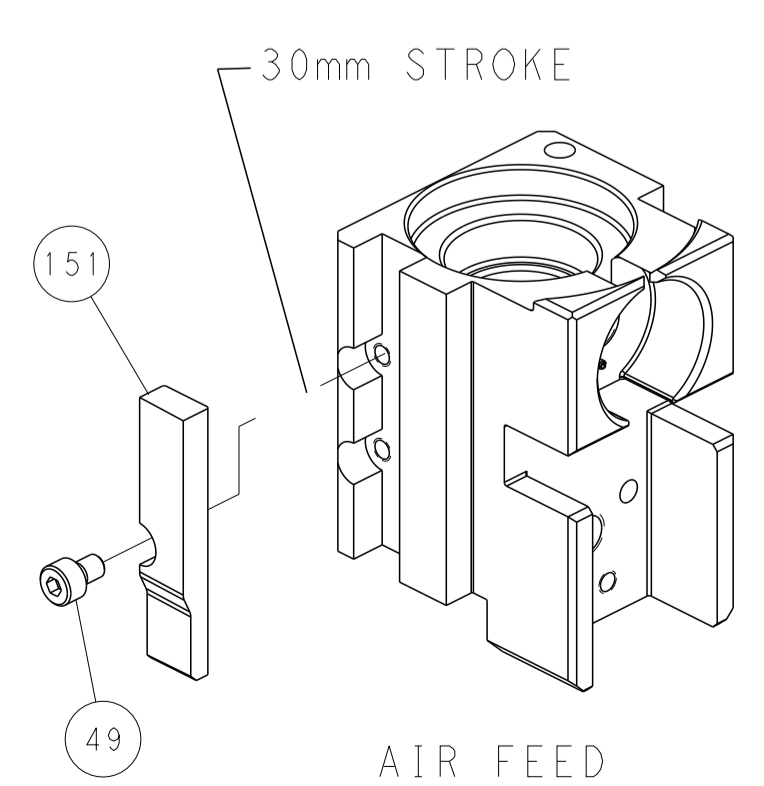

AIR FEED

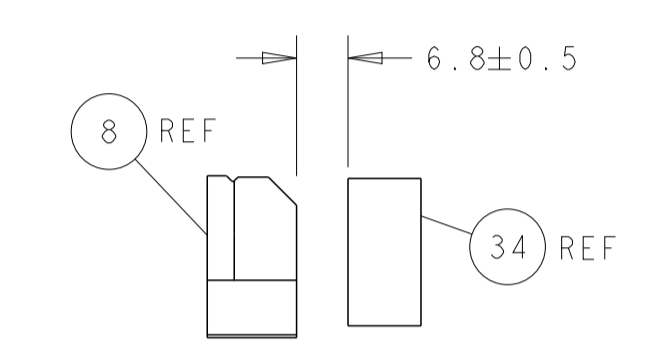
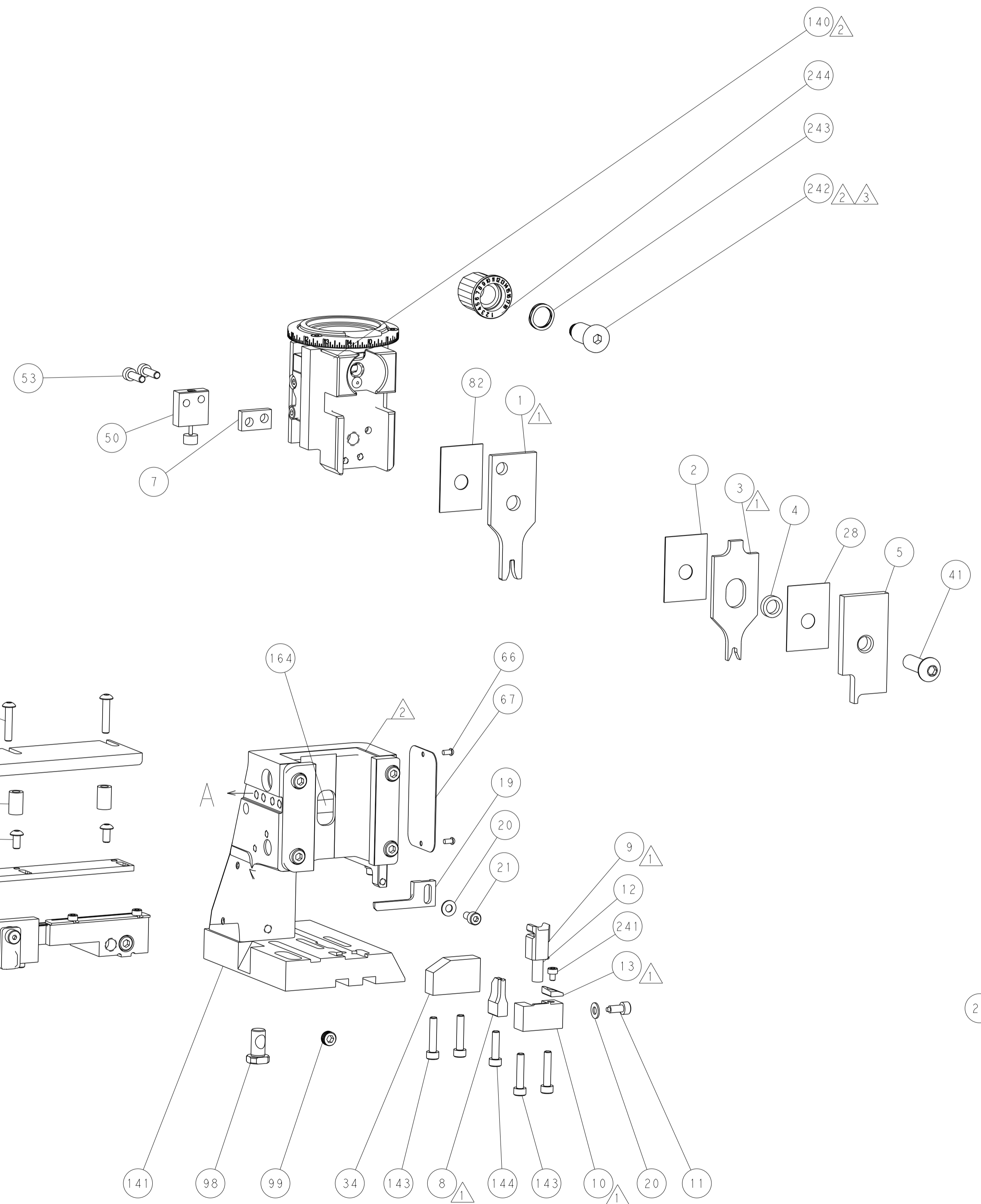

TERMINAL SUPPORT LOCATION

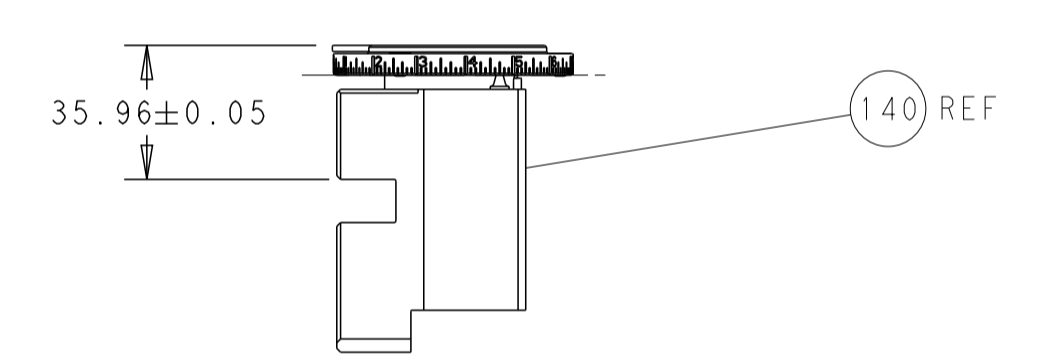

RAM SET-UP

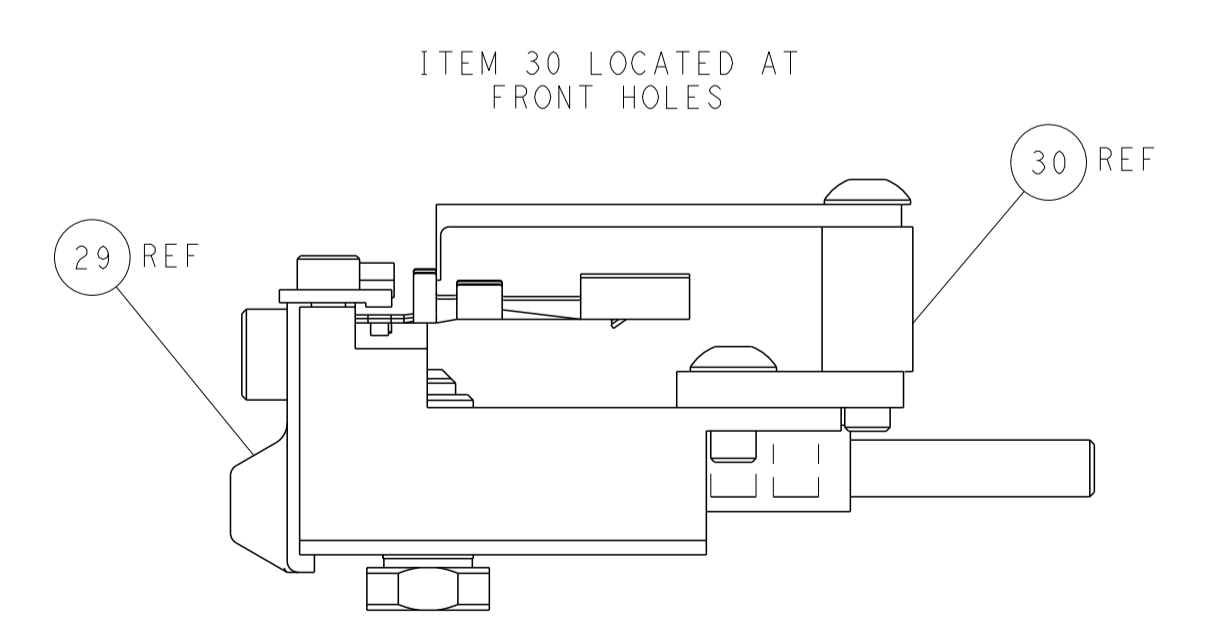

FEED TRACK POSITION
GUIDE BY INSULATION BARREL

PACIFIC VERSION
 Shown on sheets 3 of 4 & 4 of 4
 (Atlantic version shown on sheets 1 of 4 & 2 of 4)

<small>THIS DRAWING IS UNPUBLISHED. RELEASED FOR PUBLICATION 20. COPYRIGHT 20 BY TYCO ELECTRONICS CORPORATION. ALL RIGHTS RESERVED.</small>		DWN: J.HOU 30JULY2014 CHK: Y.YIN 30JULY2014 APVD: H.GUO 30JULY2014	TE Connectivity Harrisburg, PA 17105-3608
DIMENSIONS: mm TOLERANCES UNLESS OTHERWISE SPECIFIED: 0 PLC ± 1 PLC ± 2 PLC ± 3 PLC ± 4 PLC ± ANGLES ± MATERIAL: - FINISH: -		PRODUCT SPEC: - APPLICATION SPEC: - WEIGHT: - SCALE: 1:2	NAME: Ocean Side Feed Applicator SIZE: A1 CAGE CODE: 00779 DRAWING NO: C=2266451 RESTRICTED TO: - SHEET 4 OF 4 REV F