



STGB20NB32LZ STGB20NB32LZ-1

N-CHANNEL CLAMPED 20A - D²PAK/I²PAK
INTERNALLY CLAMPED PowerMESH™ IGBT

TYPE	V _{CES}	V _{CE(sat)}	I _c
STGB20NB32LZ	CLAMPED	< 2.0 V	20 A
STGB20NB32LZ-1	CLAMPED	< 2.0 V	20 A

- POLYSILICON GATE VOLTAGE DRIVEN
- LOW THRESHOLD VOLTAGE
- LOW ON-VOLTAGE DROP
- HIGH CURRENT CAPABILITY
- HIGH VOLTAGE CLAMPING FEATURE

DESCRIPTION

Using the latest high voltage technology based on a patented strip layout, STMicroelectronics has designed an advanced family of IGBTs, the PowerMESH™ IGBTs, with outstanding performances. The built in collector-gate zener exhibits a very precise active clamping while the gate-emitter zener supplies an ESD protection.

APPLICATIONS

- ELECTRONIC IGNITION FOR AUTOMOTIVE

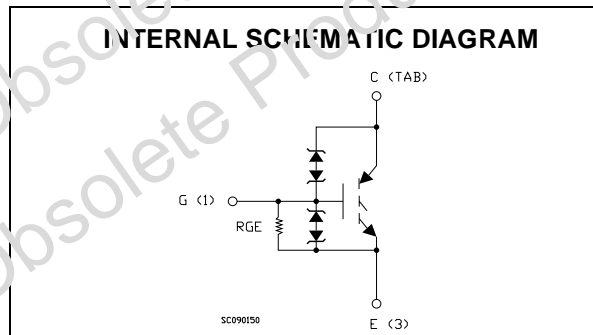
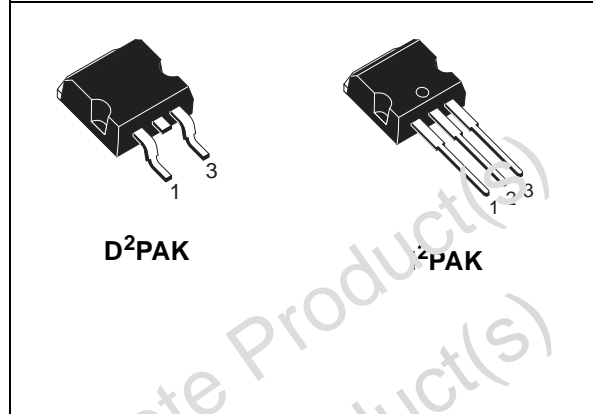

ORDERING INFORMATION

SALES TYPE	MARKING	PACKAGE	PACKAGING
STGB20NB32LZT4	GB20NB32LZ	D ² PAK	TAPE & REEL
STGB20NB32LZ-1	GB20NB32LZ	I ² PAK	TUBE

STGB20NB32LZ - STGB20NB32LZ-1

ABSOLUTE MAXIMUM RATINGS

Symbol	Parameter	Value	Unit
V_{CES}	Collector-Emitter Voltage ($V_{GS} = 0$)	CLAMPED	V
V_{ECR}	Reverse Battery Protection	20	V
V_{GE}	Gate-Emitter Voltage	CLAMPED	V
I_C	Collector Current (continuous) at $T_c = 25^\circ\text{C}$	40	A
I_C	Collector Current (continuous) at $T_c = 100^\circ\text{C}$	30	A
$I_{CM}(\bullet)$	Collector Current (pulsed)	80	A
E_{as}	Single Pulse Energy $T_c = 25^\circ\text{C}$	700	mJ
P_{tot}	Total Dissipation at $T_c = 25^\circ\text{C}$	150	W
	Derating Factor	1	W/ $^\circ\text{C}$
E_{SD}	ESD (Human Body Model)	4	KV
T_{stg}	Storage Temperature	-65 to 175	$^\circ\text{C}$
T_j	Max. Operating Junction Temperature	175	$^\circ\text{C}$

(\bullet)Pulse width limited by safe operating area

THERMAL DATA

$R_{thj-case}$	Thermal Resistance Junction-case Max	1	$^\circ\text{C}/\text{W}$
$R_{thj-amb}$	Thermal Resistance Junction-ambient Max	62.5	$^\circ\text{C}/\text{W}$

ELECTRICAL CHARACTERISTICS ($T_{CASE} = 25^\circ\text{C}$ UNLESS OTHERWISE SPECIFIED) OFF

Symbol	Parameter	Test Conditions	Min.	Typ.	Max.	Unit
$BV_{(CES)}$	Clamped Voltage	$I_C = 2\text{ mA}, V_{GE} = 0, T_c = -40^\circ\text{C}$	330	355	380	V
		$I_C = 2\text{ mA}, V_{GE} = 0, T_c = 25^\circ\text{C}$	325	350	375	V
		$I_C = 2\text{ mA}, V_{GE} = 0, T_c = 150^\circ\text{C}$	320	345	370	V
$BV_{(ECR)}$	Emitter Collector Break-down Voltage	$I_C = 75\text{ mA}, T_c = 25^\circ\text{C}$	20	28		V
BV_{GE}	Gate Emitter Break-down Voltage	$I_G = \pm 2\text{ mA}$	12	14	16	V
I_{CES}	Collector cut-off Current ($V_{GE} = 0$)	$V_{CE} = 15\text{ V}, V_{GE} = 0, T_c = 150^\circ\text{C}$			10	μA
		$V_{CE} = 200\text{ V}, V_{GE} = 0, T_c = 150^\circ\text{C}$			100	μA
I_{GES}	Gate-Emitter Leakage Current ($V_{CE} = 0$)	$V_{GE} = \pm 10\text{ V}, V_{CE} = 0$	± 400	± 660	± 1000	μA
R_{GE}	Gate Emitter Resistance		10	15	25	$\text{K}\Omega$

ON (1)

Symbol	Parameter	Test Conditions	Min.	Typ.	Max.	Unit
$V_{GE(th)}$	Gate Threshold Voltage	$V_{CE} = V_{GE}, I_C = 250\mu\text{A}, T_c = -40^\circ\text{C}$	1.2			V
		$V_{CE} = V_{GE}, I_C = 250\mu\text{A}, T_c = 25^\circ\text{C}$	1	1.4	2	V
		$V_{CE} = V_{GE}, I_C = 250\mu\text{A}, T_c = 150^\circ\text{C}$	0.6			V
$V_{CE(SAT)}$	Collector-Emitter Saturation Voltage	$V_{GE} = 4.5\text{ V}, I_C = 10\text{ A}, T_c = 25^\circ\text{C}$		1.1	1.8	V
		$V_{GE} = 4.5\text{ V}, I_C = 10\text{ A}, T_c = 150^\circ\text{C}$		1	1.7	V
		$V_{GE} = 4.5\text{ V}, I_C = 20\text{ A}, T_c = 25^\circ\text{C}$		1.35	2	V
		$V_{GE} = 4.5\text{ V}, I_C = 20\text{ A}, T_c = 150^\circ\text{C}$		1.25	2	V

ELECTRICAL CHARACTERISTICS (T_{CASE} = 25 °C UNLESS OTHERWISE SPECIFIED)
DYNAMIC

Symbol	Parameter	Test Conditions	Min.	Typ.	Max.	Unit
g _{fs}	Forward Transconductance	V _{CE} = 25 V, I _C = 20 A		35		S
C _{ies}	Input Capacitance	V _{CE} = 25 V, f = 1 MHz, V _{GE} = 0		2300		pF
C _{oes}	Output Capacitance			165		pF
C _{res}	Reverse Transfer Capacitance			28		pF
Q _g	Gate Charge	V _{CE} = 280 V, I _C = 20 A, V _{GE} = 5 V		51		nC

FUNCTIONAL CHARACTERISTICS

Symbol	Parameter	Test Conditions	Min.	Typ.	Max.	Unit
I _l	Latching Current	R _{Goff} = 127Ω, V _{Clamp} = 250 V, V _{GE} = 5 V, T _C = 125 °C	34			A
U.I.S.	Functional Test Open Secondary Coil	R _{Goff} = 1KΩ, T _C = 125°C, V _G = 5 V, L = 1.6mH	21.6			A

SWITCHING ON

Symbol	Parameter	Test Conditions	Min.	Typ.	Max.	Unit
t _{d(on)} t _r	Delay Time Rise Time	V _{CC} = 250 V, I _C = 20 A R _G = 1KΩ, V _{GE} = 4.5 V		2.3 0.6		μs μs
(di/dt) _{on}	Turn-on Current Slope	V _{CC} = 250 V, I _C = 20 A R _G = 1KΩ, V _{GE} = 4.5 V		550		A/μs
E _{on}	Turn-on Switching Losses	V _{CC} = 250 V, I _C = 20 A, T _C = 25°C R _G = 1KΩ, V _{GE} = 4.5 V, T _C = 150°C		8.8 9.2		mJ mJ

SWITCHING OFF

Symbol	Parameter	Test Conditions	Min.	Typ.	Max.	Unit	
t _c	Cross-Over Time	V _{CC} = 250 V, I _C = 20 A, R _{GE} = 1 KΩ, V _{GE} = 4.5 V		4.8		μs	
t _{r(Voff)}	Off Voltage Rise Time			2.6		μs	
t _f	Fall Time			2		μs	
t _{d(off)}	Off Voltage Delay Time	V _{CC} = 250 V, I _C = 20 A, R _{GE} = 1 KΩ, V _{GE} = 4.5 V T _C = 150 °C		11.5		μs	
E _{off(**)}	Turn-off Switching Loss			11.8		mJ	
t _c	Cross-Over Time				7.8		μs
t _{r(Voff)}	Off Voltage Rise Time				3.5		μs
t _f	Fall Time			3.9		μs	
t _{d(off)}	Off Voltage Delay Time			12		μs	
E _{off(**)}	Turn-off Switching Loss			17.8		mJ	

(**)Losses Include Also the Tail (jedec Standardization)

STGB20NB32LZ - STGB20NB32LZ-1

Output Characteristics

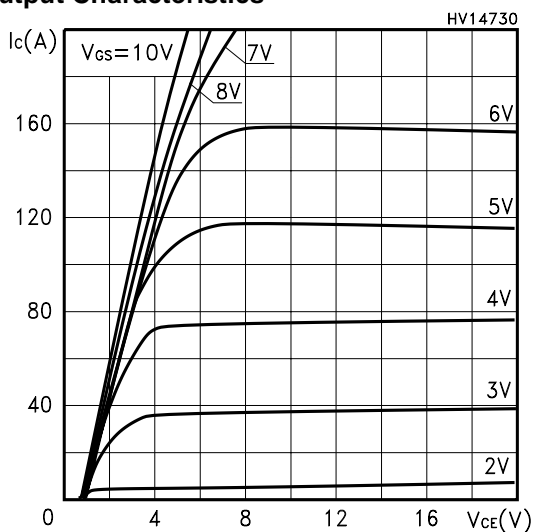

Transfer Characteristics

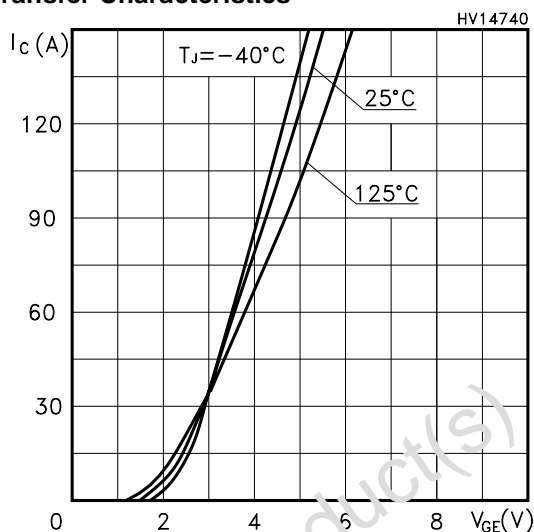

Normalized Gate Threshold Voltage vs Temp.

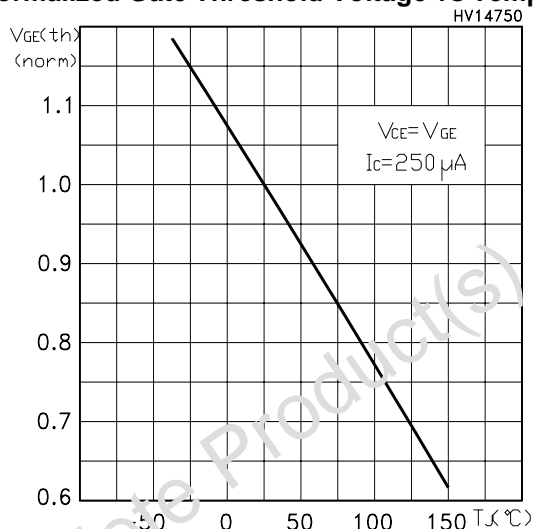

Transconductance

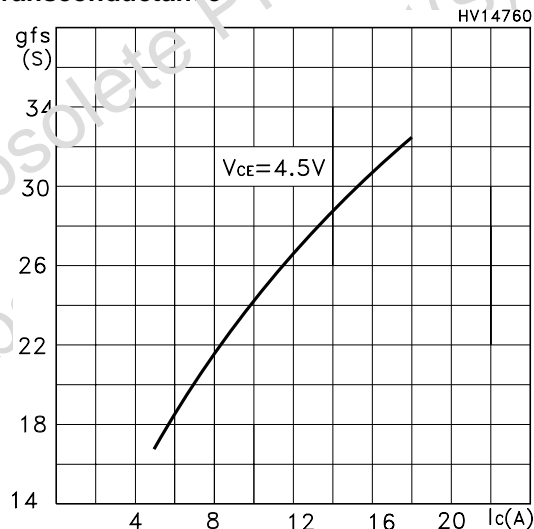

Collector-Emitter On Voltage vs Temperature

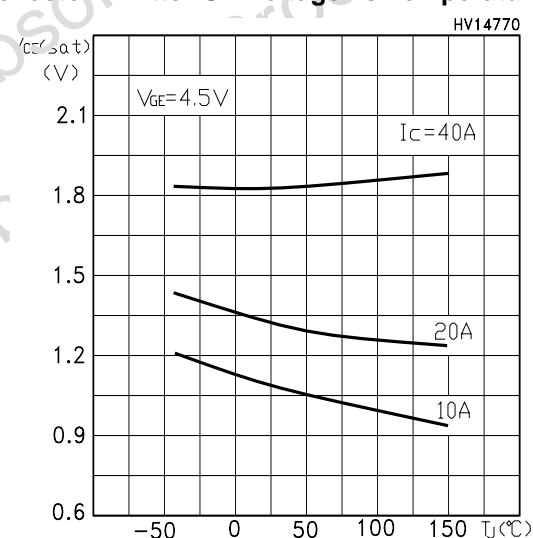

Capacitance Variations

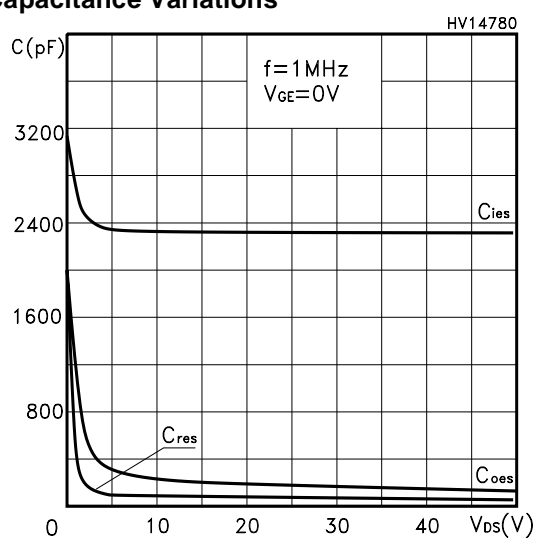

Gate Charge vs Gate-Emitter Voltage

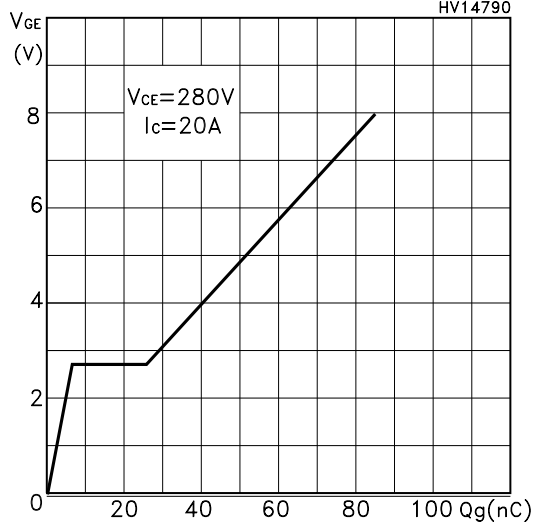

Normalized BreakDown Voltage vs Temperature

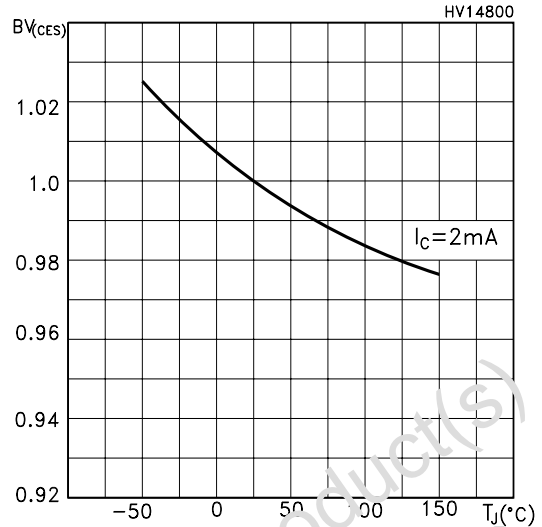

Break-Down Voltage vs Emitter Resistance

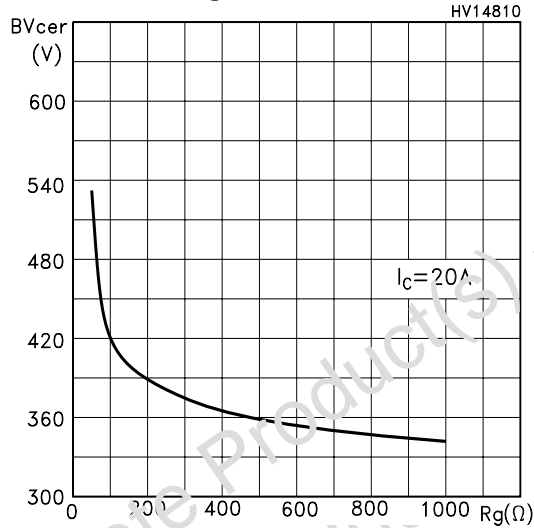

BVGE0 (Zener Gate-Emitter) vs Temperature

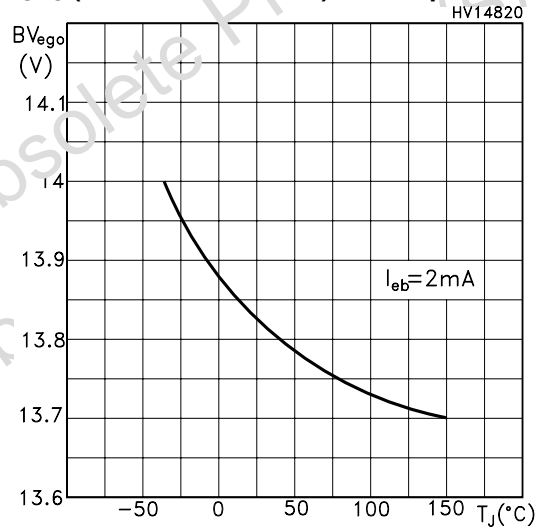

Self Clamped Inductive Switching Energy vs Open Secondary Coil

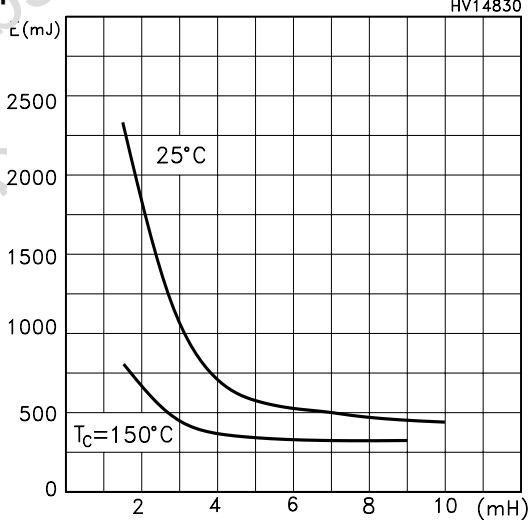

dV/dt Gate-Emitter Resistance

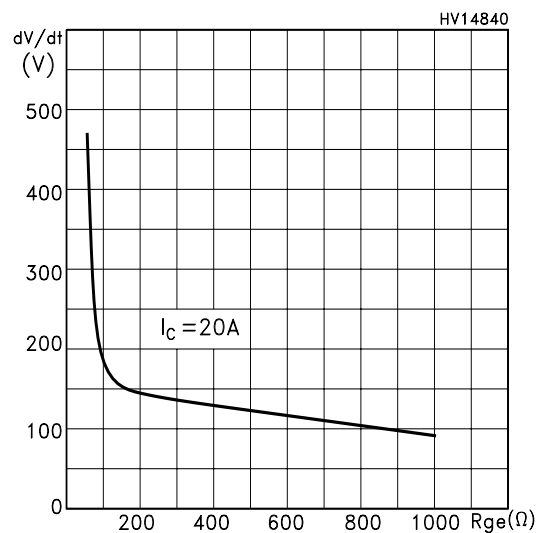

STGB20NB32LZ - STGB20NB32LZ-1

B_{VEC} Reverse Battery Voltage

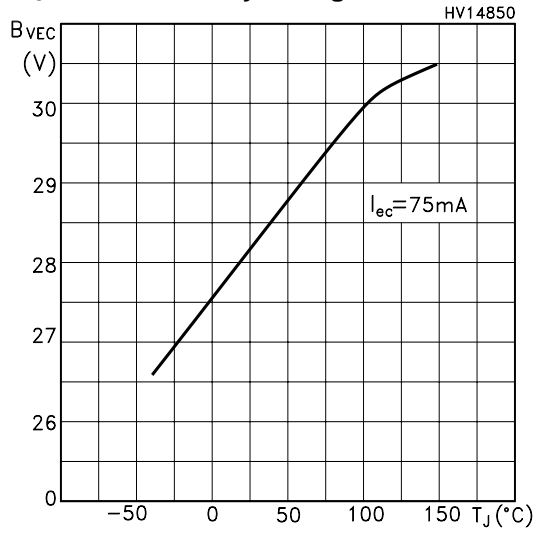

Thermal Impedance

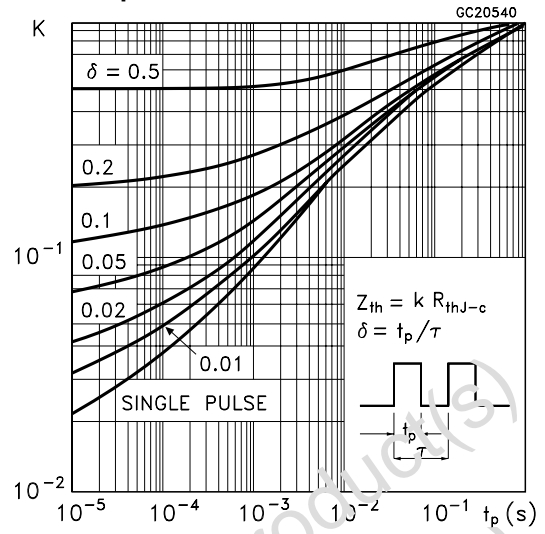

Switching Off Safe Operating Area

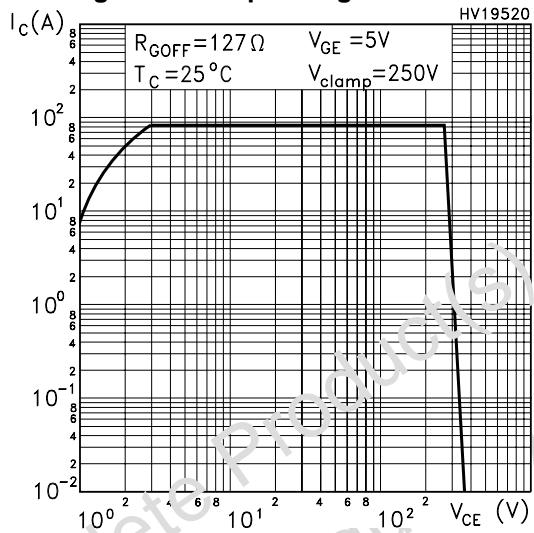

Fig. 1: Unclamped Inductive Load Test Circuit

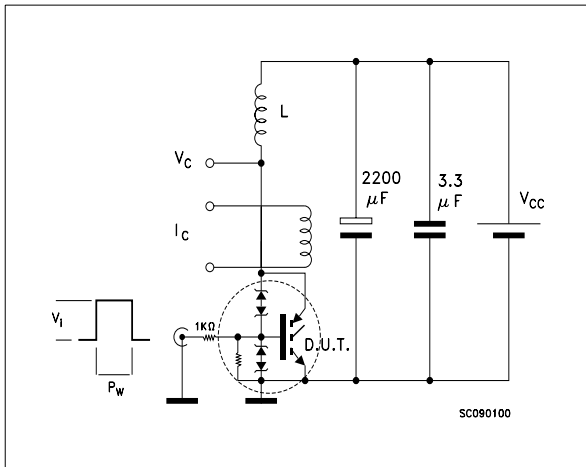

Fig. 2: Unclamped Inductive Waveform

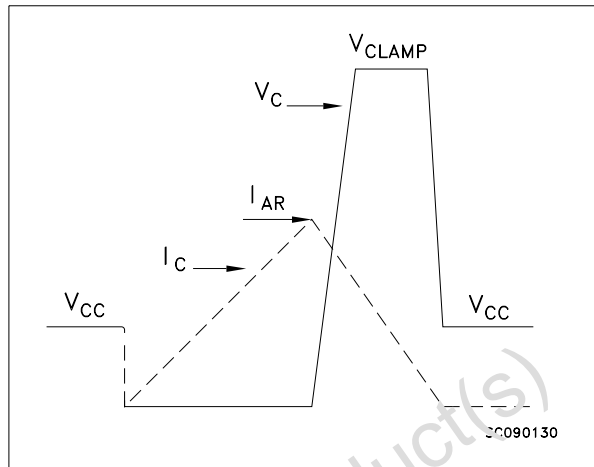

Fig. 3: Test Circuit For Inductive Load Switching And Diode Recovery Times

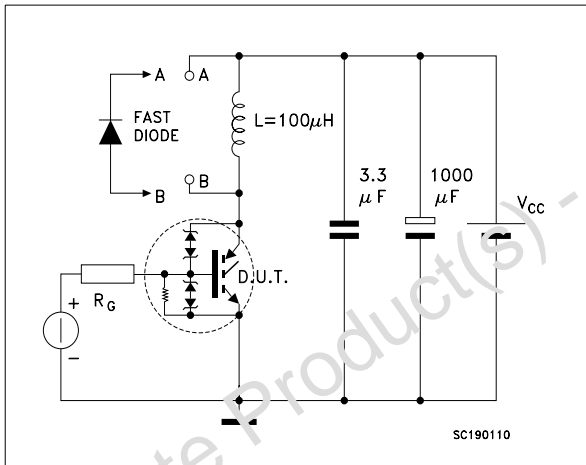
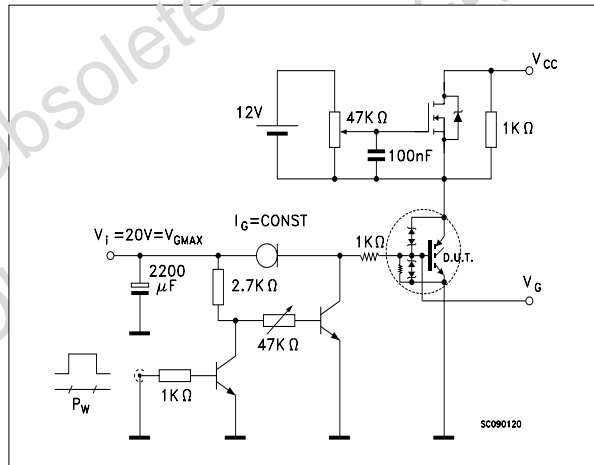
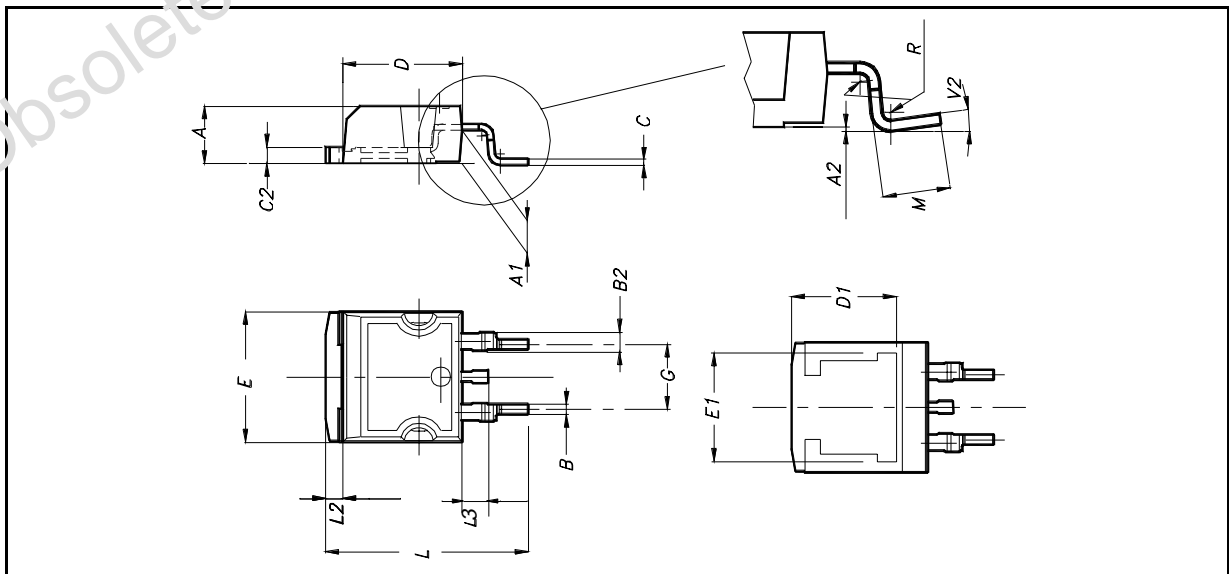

Fig. 4: Gate Charge test Circuit



D²PAK MECHANICAL DATA

DIM.	mm.			inch		
	MIN.	TYP	MAX.	MIN.	TYP.	MAX.
A	4.4		4.6	0.173		0.181
A1	2.49		2.69	0.098		0.106
A2	0.03		0.23	0.001		0.009
B	0.7		0.93	0.027		0.036
B2	1.14		1.7	0.044		0.067
C	0.45		0.6	0.017		0.023
C2	1.23		1.36	0.048		0.053
D	8.95		9.35	0.352		0.368
D1		8			0.315	
E	10		10.4	0.393		
E1		8.5			0.334	
G	4.88		5.23	0.192		0.208
L	15		15.95	0.590		0.625
L2	1.27		1.4	0.050		0.055
L3	1.4		1.75	0.055		0.068
M	2.4		3.2	0.094		0.126
R		0.4			0.015	
V2			8°			



TO-262 (I²PAK) MECHANICAL DATA

DIM.	mm.			inch		
	MIN.	TYP.	MAX.	MIN.	TYP.	MAX.
A	4.40		4.60	0.173		0.181
A1	2.40		2.72	0.094		0.107
b	0.61		0.88	0.024		0.034
b1	1.14		1.70	0.044		0.066
c	0.49		0.70	0.019		0.027
c2	1.23		1.32	0.048		0.052
D	8.95		9.35	0.352		0.368
e	2.40		2.70	0.094		0.106
e1	4.95		5.15	0.194		0.202
E	10		10.40	0.393		0.410
L	13		14	0.511		0.551
L1	3.50		3.93	0.137		0.154
L2	1.27		1.40	0.050		0.055

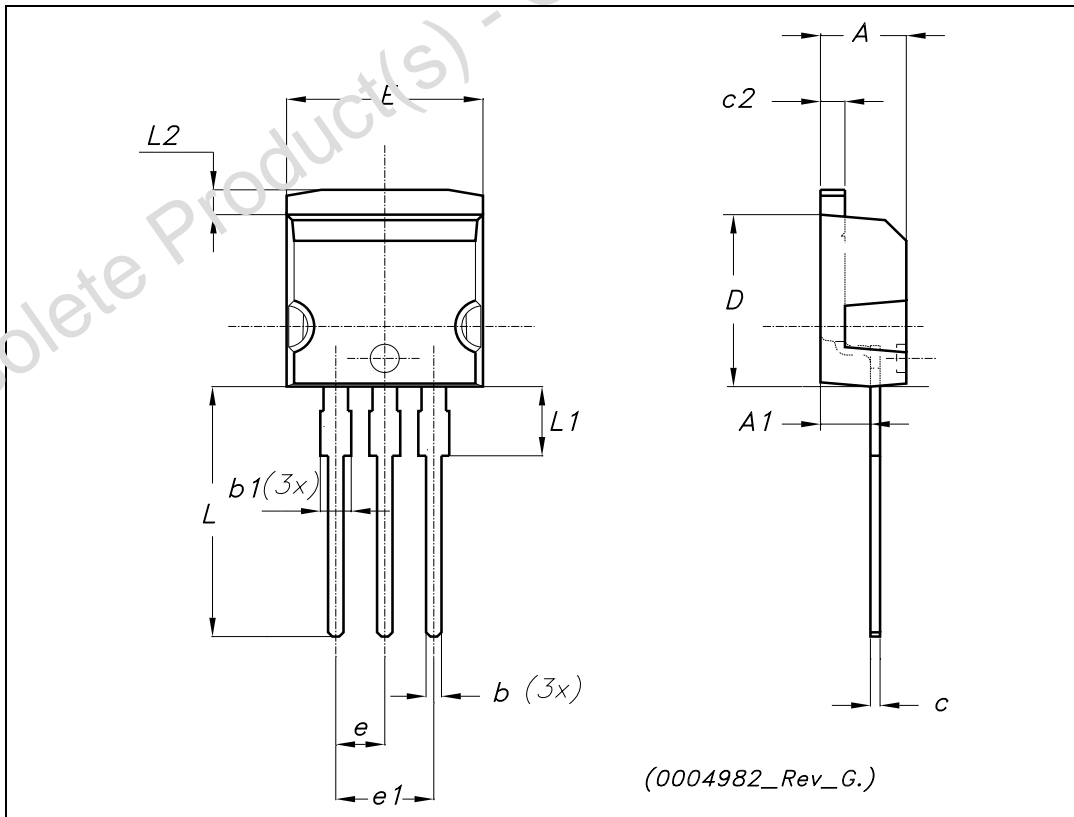

D²PAK FOOTPRINT

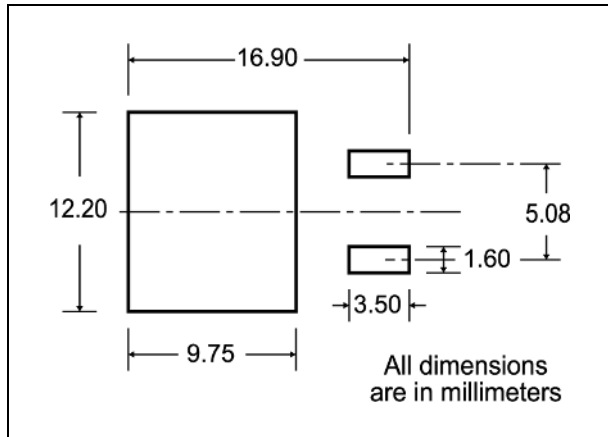

TUBE SHIPMENT (no suffix)*

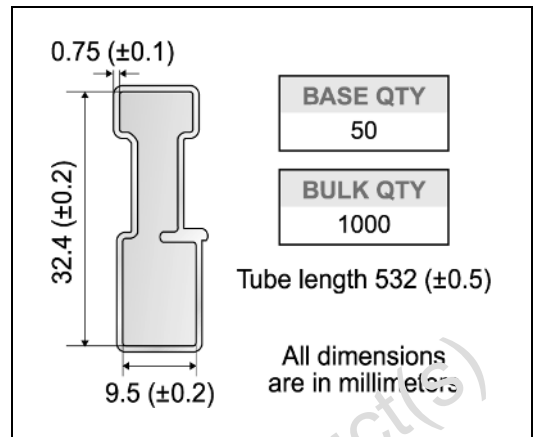

TAPE AND REEL SHIPMENT (suffix "T4")*

TAPE MECHANICAL DATA

DIM.	mm		inch	
	MIN.	MAX.	MIN.	MAX.
A0	10.5	10.7	0.413	0.421
B0	15.7	15.9	0.618	0.626
D	1.5	1.6	0.059	0.063
D1	1.59	1.61	0.062	0.063
E	1.65	1.85	0.065	0.073
F	11.4	11.6	0.449	0.456
K0	4.8	5.0	0.189	0.197
P0	3.9	4.1	0.153	0.161
P1	11.9	12.1	0.468	0.476
P2	1.9	2.1	0.075	0.082
R	50		1.574	
T	0.25	0.35	0.0098	0.0137
W	23.7	24.3	0.933	0.956

REEL MECHANICAL DATA

DIM.	mm		inch	
	MIN.	MAX.	MIN.	MAX.
A		330		12.992
B	1.5		0.059	
C	12.8	13.2	0.504	0.520
D	20.2		0.795	
G	24.4	26.4	0.960	1.039
N	100		3.937	
T		30.4		1.197

BASE QTY	BULK QTY
1000	1000

* on sales type
10/11



Obsolete Product(s) - Obsolete Product(s)

Information furnished is believed to be accurate and reliable. However, STMicroelectronics assumes no responsibility for the consequences of use of such information nor for any infringement of patents or other rights of third parties which may result from its use. No license is granted by implication or otherwise under any patent or patent rights of STMicroelectronics. Specifications mentioned in this publication are subject to change without notice. This publication supersedes and replaces all information previously supplied. STMicroelectronics products are not authorized for use as critical components in life support devices or systems without express written approval of STMicroelectronics.

© The ST logo is a registered trademark of STMicroelectronics

© 2003 STMicroelectronics - Printed in Italy - All Rights Reserved
STMicroelectronics GROUP OF COMPANIES

Australia - Brazil - Canada - China - Finland - France - Germany - Hong Kong - India - Israel - Italy - Japan - Malaysia - Malta - Morocco
Singapore - Spain - Sweden - Switzerland - United Kingdom - United States.

© <http://www.st.com>