

Product Document

AS5140H

10-Bit 360° Programmable Magnetic Rotary Encoder For High Ambient Temperatures

General Description

The AS5140H is a contactless magnetic rotary encoder for accurate angular measurement over a full turn of 360° and over an extended ambient temperature range of -40°C to 150°C.

It is a system-on-chip, combining integrated Hall elements, analog front end and digital signal processing in a single device.

To measure the angle, only a simple two-pole magnet, rotating over the center of the chip, is required. The magnet may be placed above or below the IC.

The absolute angle measurement provides instant indication of the magnet's angular position with a resolution of $0.35^\circ = 1024$ positions per revolution. This digital data is available as a serial bit stream and as a PWM signal. Furthermore, a user-programmable incremental output is available.

An internal voltage regulator allows the AS5140H to operate at either 3.3V or 5V supplies.

The AS5140H is pin-compatible to the AS5040; however it uses low-voltage OTP programming cells with additional programming options.

Ordering Information and Content Guide appear at end of datasheet.

Key Benefits & Features

The benefits and features of AS5140H, 10-Bit 360° Programmable Magnetic Rotary Encoder For High Ambient Temperatures are listed below:

Figure 1:
Added Value of Using AS5140H

Benefits	Features
No mechanical wear	Contactless high resolution rotational position encoding over a full turn of 360°
High resolution absolute position sensing	Two digital 10-bit absolute outputs: Serial interface and Pulse width modulated (PWM) output
Easy to use for motor control	Three incremental output modes: Quadrature A/B and Index output signal, Step / Direction and Index output signal, 3-phase commutation for brushless DC motors
Adjustable zero position	User programmable zero / index position

Benefits	Features
Tolerant to magnet misalignment	Failure detection mode for magnet placement monitoring and loss of power supply
Usable for high speed applications	Rotational speeds up to 10000 rpm
Tolerant to airgap variations	Pushbutton functionality detects movement of magnet in Z-axis
Supports daisy chain application	Serial read-out of multiple interconnected AS5140H devices using Daisy Chain mode
Fitting to automotive applications	Fully automotive qualified to AEC-Q100, grade 0
Operates up to 150°C ambient temperature	Wide ambient temperature range: -40°C to 150°C

Applications

The AS5140H is an ideal solution for automotive applications like engine compartment sensors, transmission gearbox encoder, throttle valve position control and for industrial applications like rotary sensors in high temperature environment.

Block Diagram

The functional blocks of this device for reference are shown below:

Figure 2:
AS5140H Block Diagram

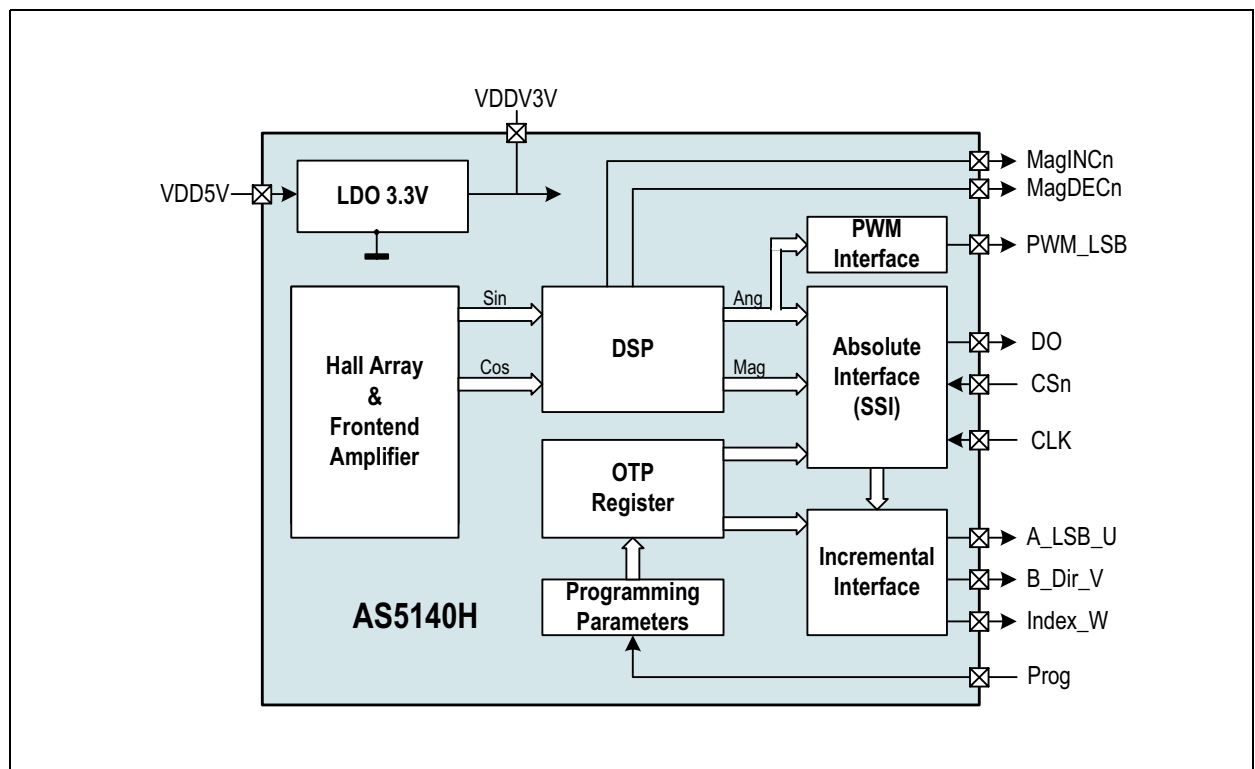

Pin Assignment

Figure 3:
Pin Diagram (Top View)

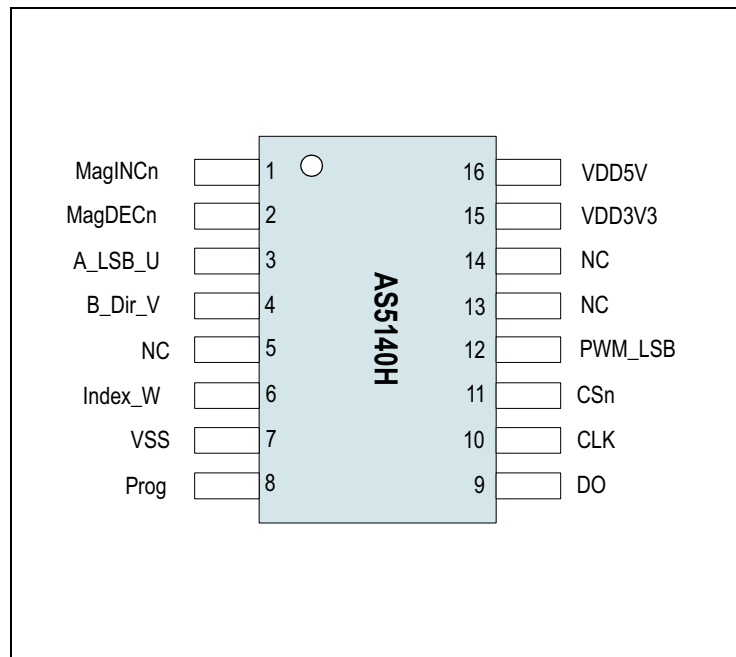

Pin Description

The following figure shows the description of each pin of the standard SSOP16 package (Shrink Small Outline Package, 16 leads, body size: 5.3mm x 6.2mm; See [Figure 3](#)).

Figure 4:
Pin Description

Pin Number	Pin Name	Description
1	MagINCn	Magnet Field Magnitude Increase. Active low. Indicates a distance reduction between the magnet and the device surface.
2	MagDECn	Magnet Field Magnitude Decrease. Active low. Indicates a distance increase between the device and the magnet.
3	A_LSB_U	Mode1.x: Quadrature A channel Mode2.x: Least Significant Bit Mode3.x: U signal (phase1)
4	B_Dir_V	Mode1.x: Quadrature B channel quarter period shift to channel A Mode2.x: Direction of Rotation Mode3.x: V signal (phase2)
5	NC	For internal use. Must be left unconnected.
6	Index_W	Mode1.x and Mode2.x: Index signal indicates the absolute zero position Mode3.x: W signal (phase3)

Pin Number	Pin Name	Description
7	VSS	Negative Supply Voltage (GND).
8	Prog	OTP Programming Input and Data Input for Daisy Chain mode. Internal pull-down resistor (~74kΩ). May be connected to VSS if programming is not used.
9	DO	Data Output of Synchronous Serial Interface.
10	CLK	SSI Clock Input. Schmitt-Trigger input.
11	CSn	Chip Select. Active low; Schmitt-Trigger input, internal pull-up resistor (~50kΩ) connect to VSS in incremental mode (see Incremental Power-up Lock Option on page 21)
12	PWM_LSB	Pulse Width Modulation of approx. 1kHz; LSB in Mode3.x
13	NC	For internal use. Must be left unconnected.
14	NC	For internal use. Must be left unconnected.
15	VDD3V3	3V-Regulator Output (see Figure 38)
16	VDD5V	Positive Supply Voltage 5V

Pin 1 and 2 are the magnetic field change indicators, MagINCn and MagDECn (magnetic field strength increase or decrease through variation of the distance between the magnet and the device). These outputs can be used to detect the valid magnetic field range. Furthermore those indicators can also be used for contact-less push-button functionality. Pins 3, 4 and 6 are the incremental pulse output pins. The functionality of these pins can be configured through programming the one-time programmable (OTP) register.

Figure 5:
Pin Assignment for Different Incremental Output Modes

Output Mode	Pin 3	Pin 4	Pin 6	Pin 12
1.x: Quadrature	A	B	Index	PWM
2.x: Step/direction	LSB	Direction	Index	PWM
3.x: Commutation	U	V	W	LSB

Mode 1.x: Quadrature A/B Output

Represents the default quadrature A/B signal mode.

Mode 2.x: Step / Direction Output

Configures pin 3 to deliver up to 512 pulses (up to 1024 state changes) per revolution. It is equivalent to the LSB (least significant bit) of the absolute position value. Pin 4 provides the information of the rotational direction.

Note(s): Both modes (mode 1.x and mode 2.x) provide an index signal (1 pulse/revolution) with an adjustable width of one LSB or three LSB's.

Mode 3.x: Brushless DC Motor Commutation Mode

In addition to the absolute encoder output over the SSI interface, this mode provides commutation signals for brushless DC motors with either one pole pair or two pole pair rotors. The commutation signals are usually provided by 3 discrete Hall switches, which are no longer required, as the AS5140H can fulfill two tasks in parallel: absolute encoder + BLDC motor commutation.

In this mode,

- Pin 12 provides the LSB output instead of the PWM (Pulse-Width-Modulation) signal.
- Pin 8 (Prog) is also used to program the different incremental interface modes, the incremental resolution and the zero position into the OTP (see [Incremental Mode Programming](#)). This pin is also used as digital input to shift serial data through the device in Daisy Chain configuration, (see [Figure 24](#)).
- Pin 11 Chip Select (CSn; active low) selects a device within a network of AS5140H encoders and initiates serial data transfer. A logic high at CSn puts the data output pin (DO) to tri-state and terminates serial data transfer. This pin is also used for alignment mode (see [Alignment Mode](#)) and programming mode (see [Programming the AS5140H](#)).
- Pin 12 allows a single wire output of the 10-bit absolute position value. The value is encoded into a pulse width modulated signal with 1 μ s pulse width per step (1 μ s to 1024 μ s over a full turn). By using an external low pass filter, the digital PWM signal is converted into an analog voltage, allowing a direct replacement of potentiometers.

Absolute Maximum Ratings

Stresses beyond those listed in Absolute maximum Ratings may cause permanent damage to the device. These are stress ratings only, and functional operation of the device at these or any other conditions beyond those indicated in [Operating Conditions](#) is not implied. Exposure to absolute maximum rating conditions for extended periods may affect device reliability.

Figure 6:
Absolute Maximum Ratings

Parameter	Min	Max	Units	Comments
DC supply voltage at pin VDD5V	-0.3	7	V	
DC supply voltage at pin VDD3V3	-0.3	5	V	
Input pin voltage	-0.3	7	V	Pins Prog, MagINCn, MagDECn, CLK, CSn
Input current (latchup immunity)	-100	100	mA	Norm: JEDEC 78
Electrostatic discharge	± 2		kV	Norm: MIL 883 E method 3015
Storage temperature	-55	150	°C	
Body temperature (Lead-free package)		260	°C	t=20 to 40s, Norm: IPC/JEDEC J-Std-020C Lead finish 100% Sn "matte tin"
Humidity non-condensing	5	85	%	
Ambient temperature	-40	150	°C	
Moisture Sensitivity Level (MSL)	3			Represents a maximum floor time of 168h

Electrical Characteristics

$T_{AMB} = -40$ to 150°C , $V_{DD5V} = 3.0$ - 3.6V (3V operation)
 $V_{DD5V} = 4.5$ - 5.5V (5V operation) unless otherwise noted.

Figure 7:
Operating Conditions

Symbol	Parameter	Condition	Min	Typ	Max	Unit
I_{supp}	Supply current			16	21	mA
VDD5V	External supply voltage at pin VDD5V	5V operation	4.5	5.0	5.5	V
VDD3V3	Internal regulator output voltage at pin VDD3V3		3.0	3.3	3.6	V
VDD5V	External supply voltage at pin VDD5V, VDD3V3	3.3V operation (pins VDD5V and VDD3V3 connected)	3.0	3.3	3.6	V
VDD3V3			3.0	3.3	3.6	V
t_{pwrup3}	External VDD3V3 supply voltage rise time at power-up	10-90% level in 3.3V mode (pins VDD5V and VDD3V3 connected)	1		150	μs

DC Characteristics for Digital Inputs and Outputs

Figure 8:
CMOS Schmitt-Trigger Inputs: CLK, CSn (CSn = Internal Pull-up)

Symbol	Parameter	Condition	Min	Typ	Max	Unit
V_{IH}	High level input voltage	Normal operation	$0.7 * V_{DD5V}$			V
V_{IL}	Low level input voltage				$0.3 * V_{DD5V}$	V
$V_{ION} - V_{IOFF}$	Schmitt Trigger hysteresis		1			V
I_{LEAK}	Input leakage current	CLK only	-1		1	μA
I_{iL}	Pull-up low level input current	CSn only, VDD5V:5.0V	-30		-100	

Figure 9:
CMOS / Program Input: Prog

Symbol	Parameter	Condition	Min	Typ	Max	Unit
V_{IH}	High level input voltage		$0.7 * V_{DD5V}$		5	V
V_{PROG}	High level input voltage	During programming	Refer to Programming Conditions			V
V_{IL}	Low level input voltage				$0.3 * V_{DD5V}$	V
I_{iL}	Pull-up high level input current	$V_{DD5V}:5.0V$			100	μA

Figure 10:
CMOS Output Open Drain: MagINCn, MagDECn

Symbol	Parameter	Condition	Min	Typ	Max	Unit
V_{OL}	Low level output voltage				$V_{SS}+0.4$	V
I_O	Output current	$V_{DD5V}:4.5V$			4	mA
		$V_{DD5V}:3V$			2	
I_{OZ}	Open drain leakage current				1	μA

Figure 11:
CMOS Output: A, B, Index, PWM

Symbol	Parameter	Condition	Min	Typ	Max	Unit
V_{OH}	High level output voltage		$V_{DD5V}-0.5$			V
V_{OL}	Low level output voltage				$V_{SS}+0.4$	V
I_O	Output current	$V_{DD5V}:4.5V$			4	mA
		$V_{DD5V}:3V$			2	

Figure 12:
Tristate CMOS Output: DO

Symbol	Parameter	Condition	Min	Typ	Max	Unit
V_{OH}	High level output voltage		VDD5V-0.5			V
V_{OL}	Low level output voltage				VSS+0.4	V
I_O	Output current	VDD5V:4.5V			4	mA
		VDD5V:3V			2	
I_{OZ}	Tri-state leakage current				1	μ A

Magnetic Input Specification

Figure 13:
Electrical Characteristics

Symbol	Parameter	Condition	Min	Typ	Max	Unit
Magnetic Input Specification (Two-pole cylindrical diametrically magnetized source)						
d_{mag}	Diameter	Recommended magnet: Ø 6mm x 2.5mm for cylindrical magnets	4	6		mm
t_{mag}	Thickness		2.5			
B_{pk}	Magnetic input field amplitude	Required vertical component of the magnetic field strength on the die's surface, measured along a concentric circle with a radius of 1.1mm	45		75	mT
B_{OFF}	Magnetic offset	Constant magnetic stray field			± 10	mT
	Field non-linearity	Including offset gradient			5	%
f_{mag_abs}	Input frequency (rotational speed of magnet)	Absolute mode: 600 rpm @ readout of 1024 positions (see Figure 33)			10	Hz
		Incremental mode: no missing pulses at rotational speeds of up to 10000 rpm (see Figure 33)			166	
Disp	Displacement radius	Max. X-Y offset between defined IC package center and magnet axis (see Figure 40)			0.25	mm
		Max. X-Y offset between chip center and magnet axis			0.485	

Symbol	Parameter	Condition	Min	Typ	Max	Unit
	Chip placement tolerance	Placement tolerance of chip within IC package (see Figure 42)			±0.235	mm
	Recommended magnet material and temperature drift	NdFeB (Neodymium Iron Boron)		-0.12		%K
		SmCo (Samarium Cobalt)		-0.035		

Electrical System Specifications

Figure 14:
Electrical System Specifications

Symbol	Parameter	Condition	Min	Typ	Max	Unit
RES	Resolution ⁽¹⁾	0.352 deg			10	bit
LSB	7 bit	Adjustable resolution only available for incremental output modes; Least significant bit, minimum step		2.813		deg
	8 bit			1.406		
	9 bit			0.703		
	10 bit			0.352		
INL _{opt}	Integral non-linearity (optimum) ⁽²⁾	Maximum error with respect to the best line fit. Verified at optimum magnet placement, T _{AMB} = 25°C			±0.5	deg
INL _{temp}	Integral non-linearity (optimum)	Maximum error with respect to the best line fit. Verified at optimum magnet placement, T _{AMB} = -40°C to 150°C			±0.9	deg
INL	Integral non-linearity	Best line fit = $(Err_{max} - Err_{min}) / 2$ Over displacement tolerance with 6mm diameter magnet, T _{AMB} = -40°C to 150°C (see Figure 19)			±1.4	deg
DNL	Differential non-linearity ⁽³⁾	10bit, no missing codes			±0.176	deg
TN	Transition noise ⁽⁴⁾	RMS equivalent to 1 sigma			0.12	Deg RMS
Hyst	Hysteresis	Incremental modes only		0.704		deg

Symbol	Parameter	Condition	Min	Typ	Max	Unit
V_{ON}	Power-on reset thresholds On voltage; 300mV typ. hysteresis	DC supply voltage 3.3V (VDD3V3)	1.37	2.2	2.9	V
V_{OFF}	Power-on reset thresholds OFF voltage; 300mV typ. hysteresis		1.08	1.9	2.6	
t_{PwrUp}	Power-up time	Until offset compensation finished			50	ms
t_{delay}	System propagation delay absolute output	Includes delay of ADC and DSP			48	μ s
	System propagation delay incremental output	Calculation over two samples			192	μ s
f_s	Sampling rate for absolute output	Internal sampling rate, $T_{AMB} = 25^{\circ}C$	9.90	10.42	10.94	kHz
		Internal sampling rate, $T_{AMB} = -40^{\circ}C$ to $150^{\circ}C$	9.38	10.42	11.46	
CLK	Read-out frequency	Max. clock frequency to read out serial data			1	MHz

Note(s) and/or Footnote(s):

1. Digital Interface.
2. Integral Non-Linearity (INL) is the maximum deviation between actual position and indicated position.
3. Differential Non-Linearity (DNL) is the maximum deviation of the step length from one position to the next.
4. Transition Noise (TN) is the repeatability of an indicated position.

Programming Conditions

$T_{AMB} = -40^{\circ}\text{C}$ to 150°C , $V_{DD5V} = 3.0\text{-}3.6\text{V}$ (3V operation)
 $V_{DD5V} = 4.5\text{-}5.5\text{V}$ (5V operation), unless otherwise noted.

Figure 15:
Programming Conditions

Symbol	Parameter	Condition	Min	Typ	Max	Unit
V_{PROG}	Programming voltage	Voltage applied during programming	3.0	3.3	3.6	V
$V_{ProgOFF}$	Programming voltage OFF level	Line must be discharged to this level	0		1	V
I_{PROG}	Programming current	Current during programming			100	mA
$R_{programmed}$	Programmed fuse resistance (log 1)	10 μ A max. current @ 100mV	100k			Ω
$R_{unprogrammed}$	Unprogrammed fuse resistance (log 0)	2mA max. current @ 100mV	50		100	Ω
t_{PROG}	Programming time per bit	Time to prog. a single fuse bit	10		20	μ s
t_{CHARGE}	Refresh time per bit	Time to charge the cap after t_{PROG}	1			μ s
f_{LOAD}	LOAD frequency	Data can be loaded at $n \cdot 2\mu$ s			500	kHz
f_{READ}	READ frequency	Read the data from the latch			2.5	MHz
f_{WRITE}	WRITE frequency	Write the data to the latch			2.5	MHz

Timing Characteristics

$T_{AMB} = -40$ to 150 °C, $V_{DD5V} = 3.0$ to $3.6V$ (3V operation)
 $V_{DD5V} = 4.5$ to $5.5V$ (5V operation), unless otherwise noted

Figure 16:
Synchronous Serial Interface (SSI)

Symbol	Parameter	Conditions	Min	Typ	Max	Units
$t_{DO\ active}$	Data output activated (logic high)	Time between falling edge of CSn and data output activated			100	ns
t_{CLKFE}	First data shifted to output register	Time between falling edge of CSn and first falling edge of CLK	500			ns
$T_{CLK/2}$	Start of data output	Rising edge of CLK shifts out one bit at a time	500			ns
$t_{DO\ valid}$	Data output valid	Time between rising edge of CLK and data output valid			413	ns
$t_{DO\ tristate}$	Data output tristate	After the last bit DO changes back to "tri-state"			100	ns
t_{CSn}	Pulse width of CSn	CSn =high; to initiate read-out of next angular position	500			ns
f_{CLK}	Read-out frequency	Clock frequency to read out serial data	>0		1	MHz

Figure 17:
Pulse Width Modulation Output

Symbol	Parameter	Conditions	Min	Typ	Max	Units
f_{PWM}	PWM frequency	Signal period = $1025\mu s \pm 5\%$ at $T_{AMB} = 25^\circ C$	0.927	0.976	1.024	kHz
		Signal period = $1025\mu s \pm 10\%$ at $T_{AMB} = -40^\circ C$ to $150^\circ C$	0.878	0.976	1.074	
PW_{MIN}	Minimum pulse width	Position 0d; angle 0 degree	0.90	1	1.10	μs
PW_{MAX}	Maximum pulse width	Position 1023d; angle 359.65 degree	922	1024	1126	μs

Figure 18:
Incremental Outputs

Symbol	Parameter	Conditions	Min	Typ	Max	Units
$t_{\text{Incremental outputs valid}}$	Incremental outputs valid after power-up	Time between first falling edge of CSn after power-up and valid incremental outputs			500	ns
$t_{\text{Dir valid}}$	Directional indication valid	Time between rising or falling edge of LSB output and valid directional indication			500	ns

Figure 19:
Integral and Differential Non-Linearity Example (Exaggerated Curve)

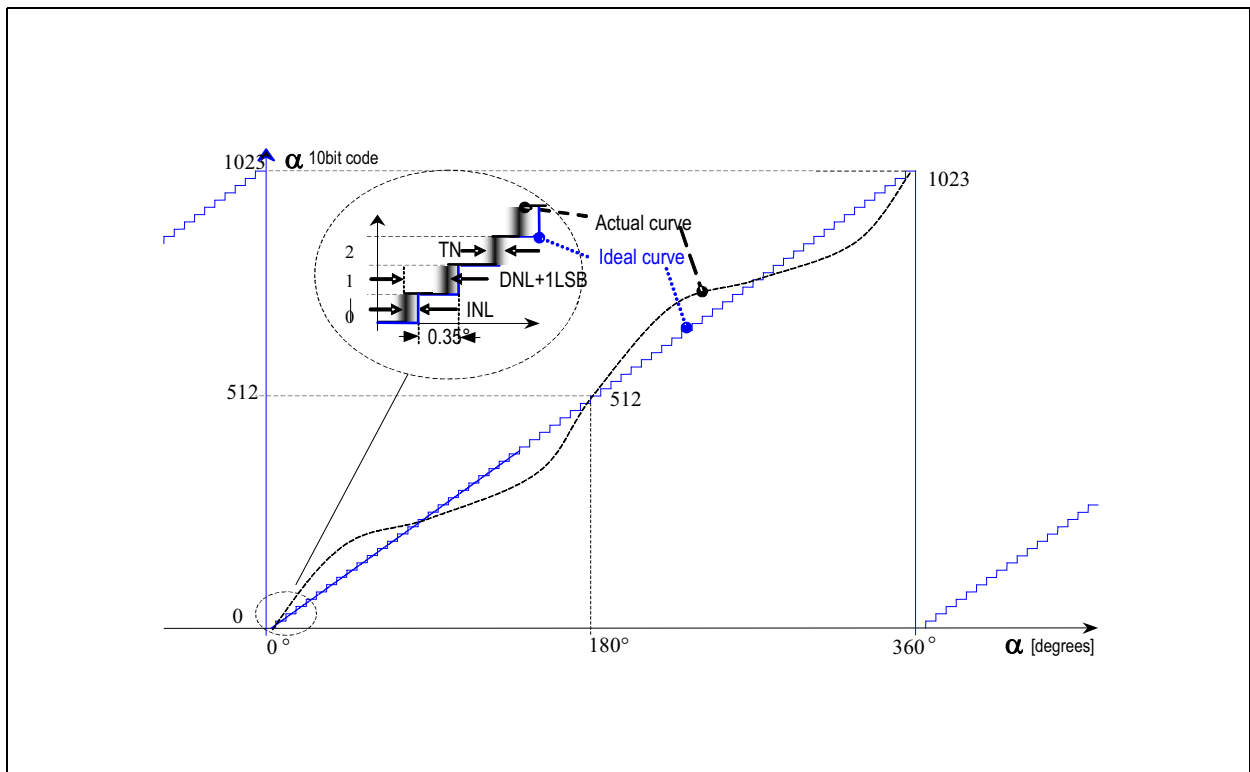

Detailed Description

The AS5140H is manufactured in a CMOS standard process and uses a spinning current Hall technology for sensing the magnetic field distribution across the surface of the chip. The integrated Hall elements are placed around the center of the device, and deliver a voltage representation of the magnetic field at the surface of the IC. Through Sigma-Delta Analog / Digital Conversion and Digital Signal-Processing (DSP) algorithms, the AS5140H provides accurate high-resolution absolute angular position information. For this purpose, a Coordinate Rotation Digital Computer (CORDIC) calculates the angle and the magnitude of the Hall array signals. The DSP is also used to provide digital information at the outputs MagINCn and MagDECn that indicate movements of the used magnet towards or away from the device's surface. A small low cost diametrically magnetized (two-pole) standard magnet provides the angular position information (see [Figure 39](#)).

The AS5140H senses the orientation of the magnetic field and calculates a 10-bit binary code. This code can be accessed via a Synchronous Serial Interface (SSI). In addition, an absolute angular representation is given by a Pulse Width Modulated signal at pin 12 (PWM). Simultaneously, the device also provides incremental output signals. The various incremental output modes can be selected by programming the OTP mode register bits (see [Figure 35](#)). As long as no programming voltage is applied to pin Prog, the new setting may be overwritten at any time and will be reset to default when power is turned off. To make the setting permanent, the OTP register must be programmed. The default setting is a quadrature A/B mode including the Index signal with a pulse width of 1 LSB. The Index signal is logic high at the user programmable zero position.

The AS5140H is tolerant to magnet misalignment and magnetic stray fields due to differential measurement technique and Hall sensor conditioning circuitry.

Figure 20:
Typical Arrangement of AS5140H and Magnet

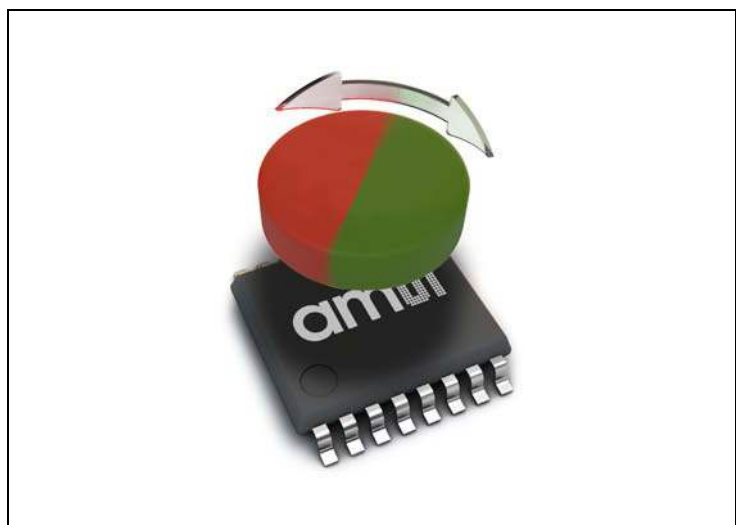

10-Bit Absolute Angular Position Output

Synchronous Serial Interface (SSI)

If CSn changes to logic low, Data Out (DO) will change from high impedance (tri-state) to logic high and the read-out will be initiated.

- After a minimum time $t_{CLK\ FE}$, data is latched into the output shift register with the first falling edge of CLK.
- Each subsequent rising CLK edge shifts out one bit of data.
- The serial word contains 16 bits; the first 10 bits are the angular information D[9:0], the subsequent 6 bits contain system information about the validity of data such as OCF, COF, LIN, Parity and Magnetic Field status (increase/decrease).
- A subsequent measurement is initiated by a log “high” pulse at CSn with a minimum duration of t_{CSn} .

Figure 21:
Synchronous Serial Interface with Absolute Angular Position Data

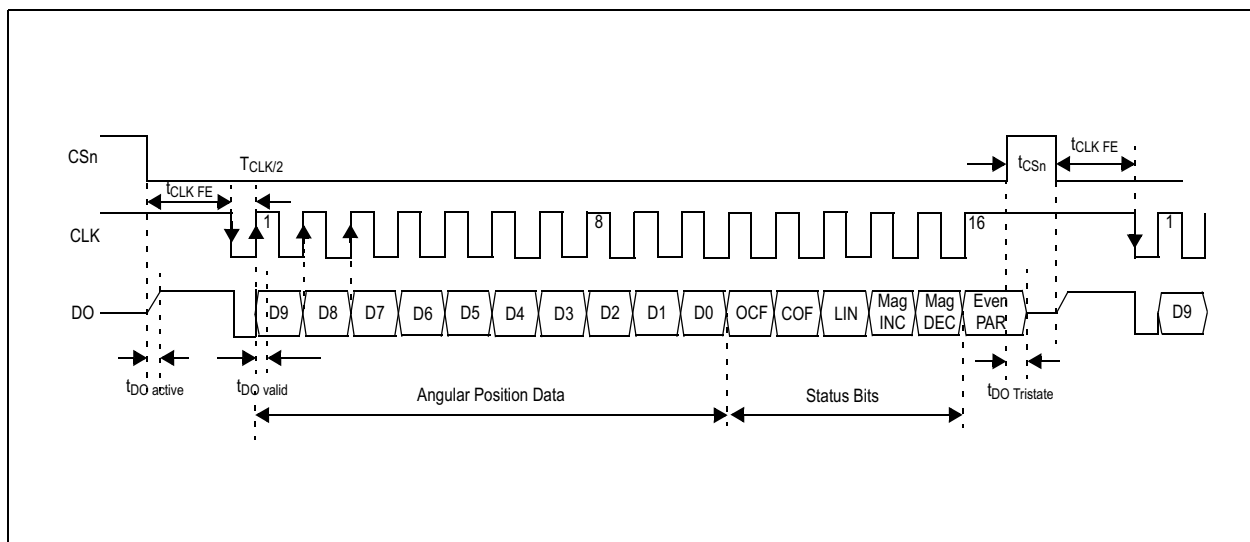

Data Content

D9:D0 – Absolute angular position data (MSB is clocked out first).

OCF – (Offset Compensation Finished). Logic high indicates the finished Offset Compensation Algorithm. For fast startup, this bit may be polled by the external microcontroller. As soon as this bit is set, the AS5140H has completed the startup and the data is valid (see [Figure 23](#)).

COF – (Cordic Overflow). Logic high indicates an out of range error in the CORDIC part. When this bit is set, the data at D9:D0 is invalid. The absolute output maintains the last valid angular value. This alarm may be resolved by bringing the magnet within the X-Y-Z tolerance limits.

LIN – (Linearity Alarm). Logic high indicates that the input field generates a critical output linearity. When this bit is set, the data at D9:D0 may still be used, but can contain invalid data. This warning may be resolved by bringing the magnet within the X-Y-Z tolerance limits.

MagINCn – (Magnitude Increase) becomes HIGH, when the magnet is pushed towards the IC, thus increasing the magnetic field strength.

MagDECn – (Magnitude Decrease) becomes HIGH, when the magnet is pulled away from the IC, thus decreasing the magnetic field strength.

Signal “HIGH” for both MagINCn and MagDECn indicate a magnetic field that is out of the allowed range (see [Figure 22](#)).

Figure 22:
Magnetic Magnitude Variation Indicator

MagINCn	MagDECn	Description
0	0	No distance change Magnetic Input Field OK (in range)
0	1	Distance increase: Pull-function. This state is dynamic, it is only active while the magnet is moving away from the chip in Z-axis.
1	0	Distance decrease: Push- function. This state is dynamic, it is only active while the magnet is moving towards the chip in Z-axis.
1	1	Magnetic Input Field invalid – out of range: Too large, too small (missing magnet).

Note(s) and/or Footnote(s):

1. Pins 1 and 2 (MagINCn, MagDECn) are open drain outputs and require external pull-up resistors. If the magnetic field is in range, both outputs are turned OFF.

The two pins may also be combined with a single pull-up resistor. In this case, the signal is high when the magnetic field is in range. It is low in all other cases (see [Figure 22](#)).

Even Parity – A bit for transmission error detection of bits 1 to 15 (D9 to D0, OCF, COF, LIN, MagINCn, MagDECn).

The absolute angular output is always set to a resolution of 10 bit. Placing the magnet above the chip, angular values increase in clockwise direction by default. Data D9:D0 is valid, when the status bits have the following configurations:

Figure 23:
Status Bit Outputs

OCF	COF	LIN	MagINCn	MagDECn	Parity
1	0	0	0	0	Even checksum of bits 1:15
			0	1	
			1	0	

The absolute angular position is sampled at a rate of 10kHz (0.1ms). This allows reading of all 1024 positions per 360 degrees within 0.1 seconds = 9.76Hz (~10Hz) without skipping any position. Multiplying 10Hz by 60, results the corresponding maximum rotational speed of 600rpm. Readout of every second angular position allows for rotational speeds of up to 1200 rpm.

Consequently, increasing the rotational speed reduces the number of absolute angular positions per revolution (see [Figure 45](#)). Regardless of the rotational speed or the number of positions to be read out, the absolute angular value is always given at the highest resolution of 10 bit.

The incremental outputs are not affected by rotational speed restrictions due to the implemented interpolator. The incremental output signals may be used for high-speed applications with rotational speeds of up to 10000 rpm without missing pulses.

Daisy Chain Mode

The Daisy Chain mode allows connection of several AS5140H’s in series, while still keeping just one digital input for data transfer (see “Data IN” in [Figure 24](#) below). This mode is accomplished by connecting the data output (DO; pin 9) to the data input (Prog; pin 8) of the subsequent device. The serial data of all connected devices is read from the DO pin of the first device in the chain. The Prog pin of the last device in the chain should be connected to VSS. The length of the serial bit stream increases with every connected device. It is,

(EQ1) $n * (16+1) \text{ bits}$

For example, 34 bits for two devices, 51 bits for three devices, etc.

The last data bit of the first device (Parity) is followed by a logic low bit and the first data bit of the second device (D9), etc. (see [Figure 25](#)).

Figure 24:
Daisy Chain Hardware Configuration

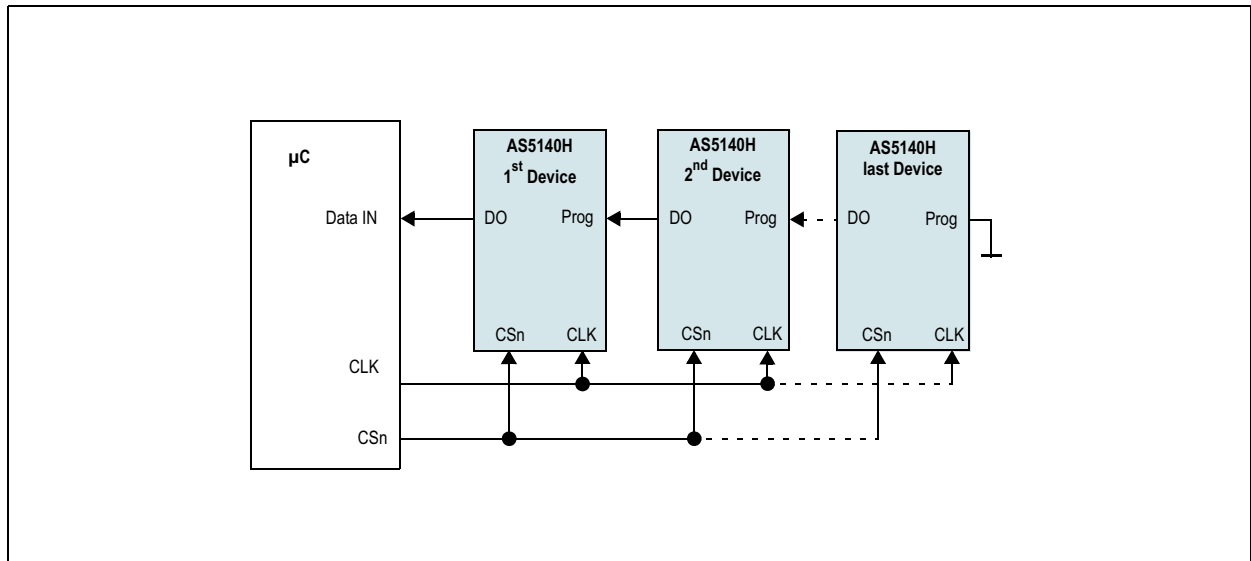
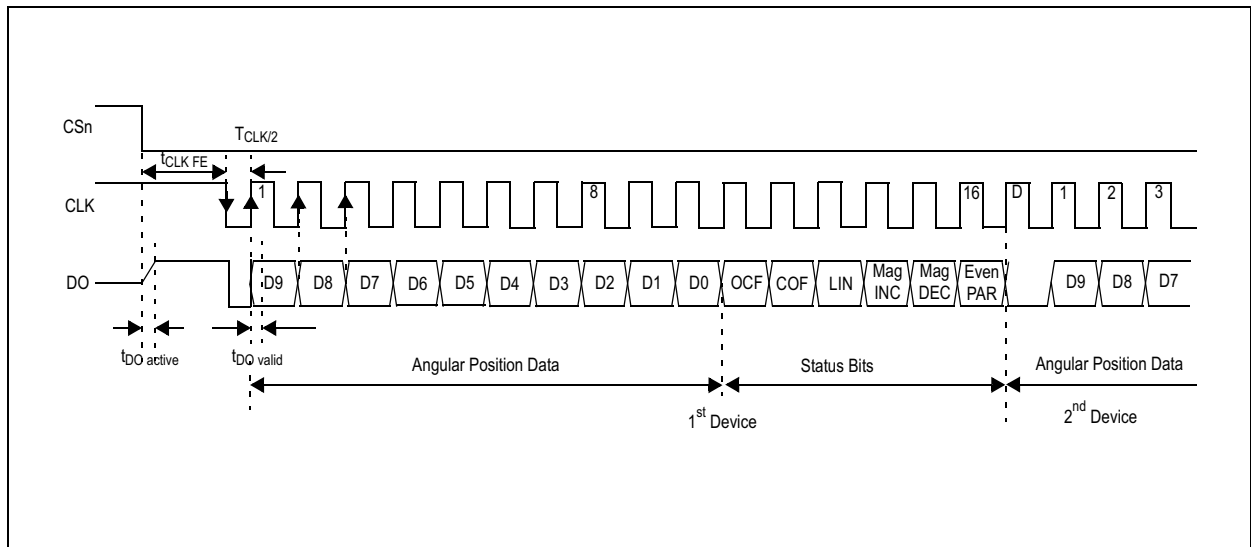

Figure 25:
Daisy Chain Mode Data Transfer



Programming Daisy Chained Devices. In Daisy Chain mode, the Prog pin is connected directly to the DO pin of the subsequent device in the chain (see Figure 24). During programming (see Programming the AS5140H), a programming voltage of 7.5V must be applied to pin Prog. This voltage level exceeds the limits for pin DO, so one of the following precautions must be made during programming:

- Open the connection DO→Prog during programming, (or)
- Add a Schottky diode between DO and Prog (Anode = DO, Cathode = Prog)

Due to the parallel connection of CLK and CSn, all connected devices may be programmed simultaneously.

Incremental Outputs

Three different incremental output modes are possible with quadrature A/B being the default mode. Figure 26 shows the two-channel quadrature as well as the step / direction incremental signal (LSB) and the direction bit in clockwise (CW) and counter-clockwise (CCW) direction.

Quadrature A/B Output (Quad A/B Mode)

The phase shift between channel A and B indicates the direction of the magnet movement. Channel A leads channel B at a clockwise rotation of the magnet (top view) by 90 electrical degrees. Channel B leads channel A at a counter-clockwise rotation.

Figure 26:
Incremental Output Modes

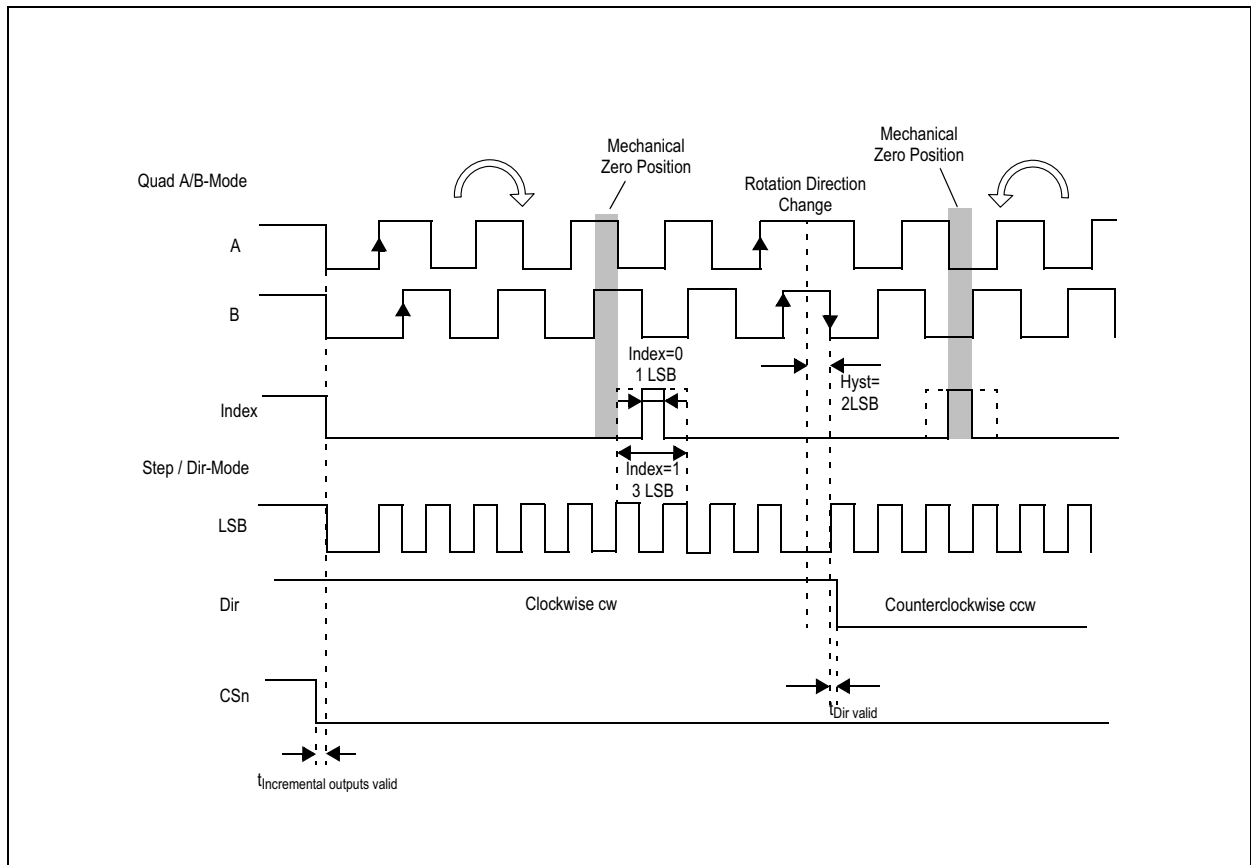

LSB Output (Step/Direction Mode)

Output LSB reflects the LSB (least significant bit) of the programmed incremental resolution (OTP Register Bit Div0, Div1). Output Dir provides information about the rotational direction of the magnet, which may be placed above or below the device (1=clockwise; 0=counter clockwise; top view). Dir is updated with every LSB change. In both modes (quad A/B, step/direction), the resolution and the index output are user programmable. The index pulse indicates the zero position and is by default one angular step (1LSB) wide. However, it can be set to three LSBs by programming the Index-bit of the OTP register accordingly (see [Figure 35](#)).

Incremental Power-up Lock Option. After power-up, the incremental outputs can optionally be locked or unlocked, depending on the status of the CSn pin:

- CSn = low at power-up: CSn has an internal pull-up resistor and must be externally pulled low ($R_{ext} \leq 5K\Omega$). If CSn is low at power-up, the incremental outputs (A, B, Index) will be high until the internal offset compensation is finished. This unique state (A=B=Index = high) may be used as an indicator for the external controller to shorten the waiting time at power-up. Instead of waiting for the specified maximum power up-time (0), the controller can start requesting data from the AS5140H as soon as the state (A=B=Index = high) is cleared.
- CSn = high or open at power-up: In this mode, the incremental outputs (A, B, Index) will remain at logic high state, until CSn goes low or a low pulse is applied at CSn. This mode allows intentional disabling of the incremental outputs until, for example the system microcontroller is ready to receive data.

Incremental Output Hysteresis

To avoid flickering incremental outputs at a stationary magnet position, a hysteresis is introduced. In case of a rotational direction change, the incremental outputs have a hysteresis of 2 LSB. Regardless of the programmed incremental resolution, the hysteresis of 2 LSB always corresponds to the highest resolution of 10 bit. In absolute terms, the hysteresis is set to 0.704 degrees for all resolutions. For constant rotational directions, every magnet position change is indicated at the incremental outputs (see [Figure 27](#)). For example, if the magnet turns clockwise from position “x+3” to “x+4”, the incremental output would also indicate this position accordingly. A change of the magnet’s rotational direction back to position “x+3” means that the incremental output still remains unchanged for the duration of 2 LSB, until position “x+2” is reached. Following this direction, the incremental outputs will again be updated with every change of the magnet position.

Figure 27:
Hysteresis Window for Incremental Outputs

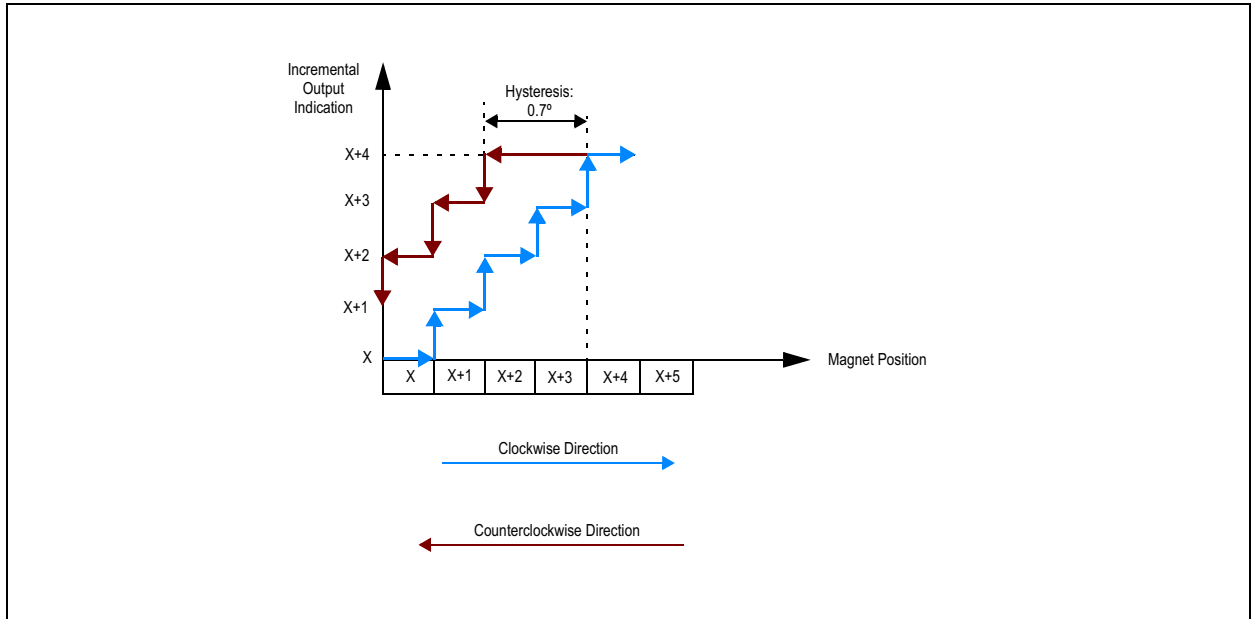

Pulse Width Modulation (PWM) Output

The AS5140H provides a pulse width modulated output (PWM), whose duty cycle is proportional to the measured angle:

$$(EQ2) \text{ Position} = \frac{t_{ON} \cdot 1025}{(t_{ON} + t_{OFF})} - 1$$

The PWM frequency is internally trimmed to an accuracy of $\pm 5\%$ ($\pm 10\%$ over full temperature range). This tolerance can be cancelled by measuring the complete duty cycle as shown above.

Figure 28:
PWM Output Signal

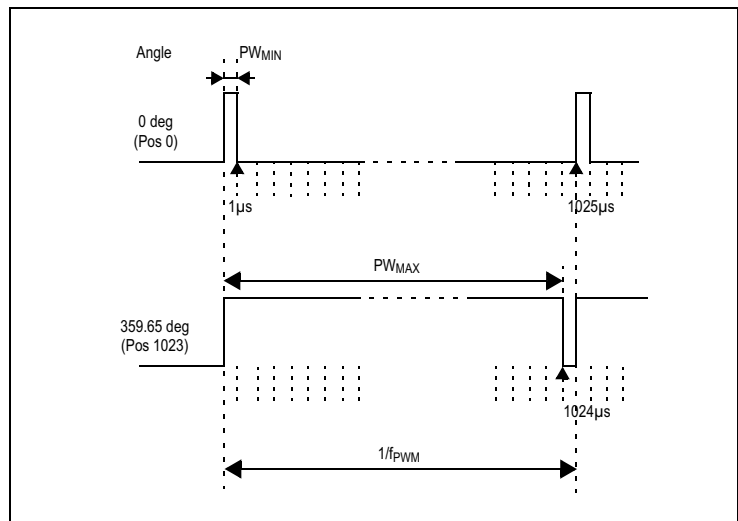

Figure 29:
PWM Signal Parameters

Symbol	Parameter	Typ	Unit	Note
f_{PWM}	PWM frequency	0.9756	kHz	Signal period: 1025 μ s
PW_{MIN}	MIN pulse width	1	μ s	Position 0d Angle 0 deg
PW_{MAX}	MAX pulse width	1024	μ s	Position 1023d Angle 359.65 deg

Analog Output

An analog output may be generated by averaging the PWM signal, using an external active or passive lowpass filter. The analog output voltage is proportional to the angle: 0° = 0V; 360° = VDD5V. Using this method, the AS5140H can be used as direct replacement of potentiometers.

Figure 30:
Simple Passive 2nd Order Lowpass Filter

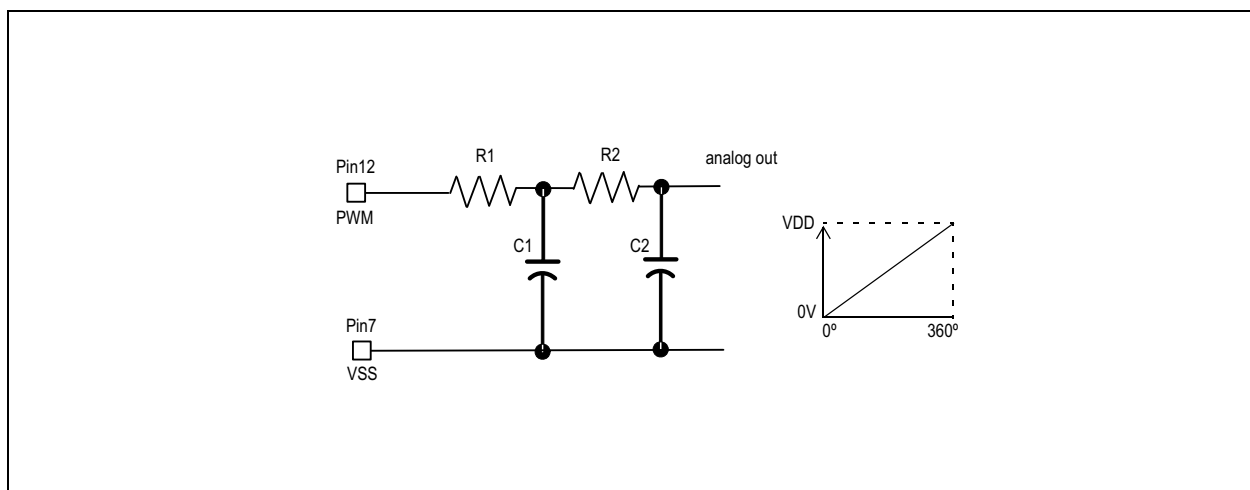

$$(EQ3) \quad R1, R2 \geq 4k\Omega \quad C1, C2 \geq 1\mu F/6V$$

R1 should be $\geq 4k\Omega$ to avoid loading of the PWM output. Larger values of R_x and C_x will provide better filtering and less ripple, but will also slow down the response time.

Brushless DC Motor Commutation Mode

Brushless DC motors require angular information for stator commutation. The AS5140H provides U-V-W commutation signals for one and two pole pair motors. In addition to the three-phase output signals, the step (LSB) output at pin 12 allows high accuracy speed measurement. Two resolutions (9 or 10 bit) can be selected by programming Div0 according to Figure 35.

Mode 3.0 (3.1) is used for brush-less DC motors with one-pole pair rotors. The three phases (U, V, W) are 120 degrees apart, each phase is 180 degrees on and 180 degrees OFF.

Mode 3.2 (3.3) is used for motors with two pole pairs requiring a higher pulse count to ensure a proper current commutation. In this case the pulse width is 256 positions, equal to 90 degrees. The precise physical angle at which the U, V and W signals change state (“Angle” in Figure 31 and Figure 32) is calculated by multiplying each transition position by the angular value of 1 count:

$$(EQ4) \quad Angle[deg] = Position \times (360 \text{ degree}/1024)$$

Figure 31:
U, V and W-Signals for BLDC Motor Commutation (Div1=0, Div0=0)

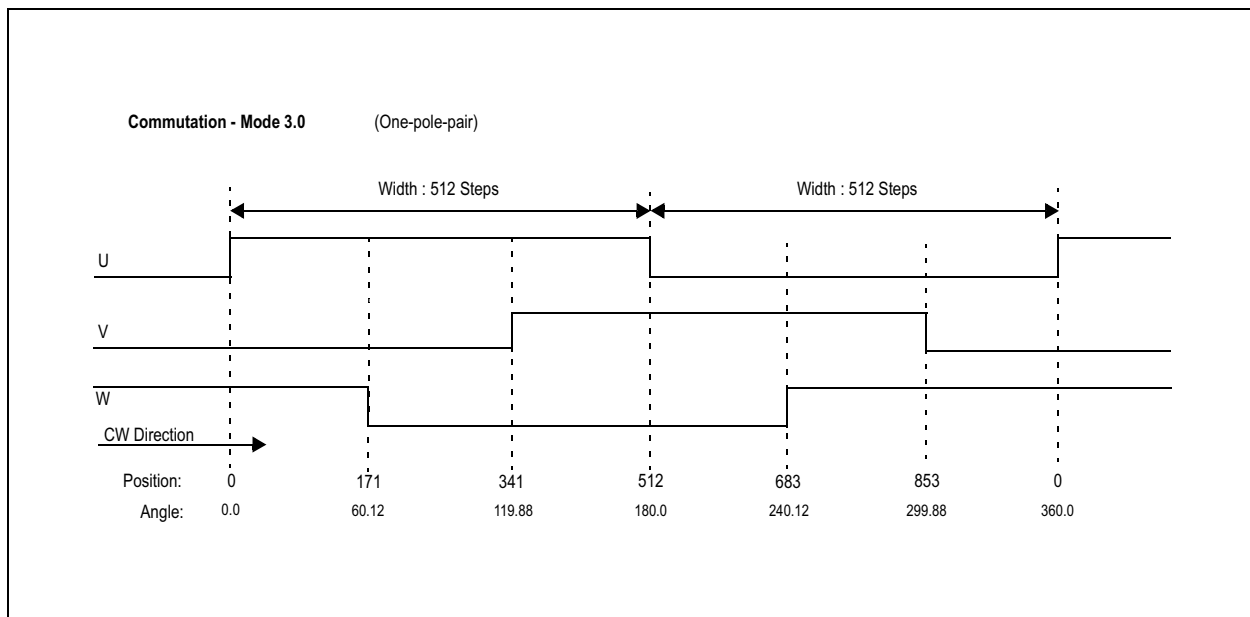
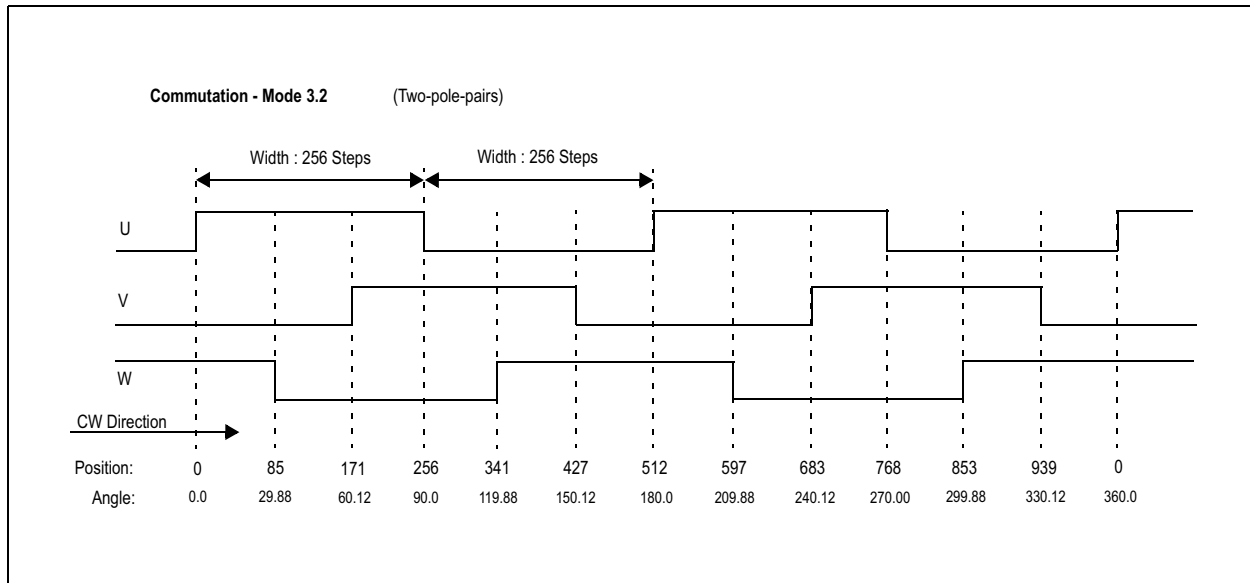

Figure 32:
U, V and W-Signals for 2Pole BLDC Motor Commutation (Div1=1, Div0=0)



Programming the AS5140H

Note(s): A detailed description of the **ams** low voltage polyfuse OTP programming method is given in Application Note AN514X-10, which can be downloaded from the **ams** website. The OTP programming description in this datasheet is for general information only.

After power-on, programming the AS5140H is enabled with the rising edge of CSn with Prog = high and CLK = low. The AS5140H programming is a one-time-programming (OTP) method, based on polysilicon fuses. The advantage of this method is that a programming voltage of only 3.3V is required for programming. The OTP consists of 52 bits, of which 21 bits are available for user programming. The remaining 31 bits contain factory settings and a unique chip identifier (Chip-ID).

A single OTP cell can be programmed only once. Per default, the cell is "0"; a programmed cell will contain a "1". While it is not possible to reset a programmed bit from "1" to "0", multiple OTP writes are possible, as long as only unprogrammed "0"-bits are programmed to "1". Independent of the OTP programming, it is possible to overwrite the OTP register temporarily with an OTP write command at any time. This setting will be cleared and overwritten with the hard programmed OTP settings at each power-up sequence or by a LOAD operation.

The OTP memory can be accessed in several ways:

- **Load Operation:** The Load operation reads the OTP fuses and loads the contents into the OTP register. Note that the Load operation is automatically executed after each power-on-reset.
- **Write Operation:** The Write operation allows a temporary modification of the OTP register. It does not program the OTP. This operation can be invoked multiple times, and will remain set while the chip is supplied with power and while the OTP register is not modified with another Write or Load operation.
- **Read Operation:** The Read operation reads the contents of the OTP register, for example to verify a Write command or to read the OTP memory after a Load command.
- **Program Operation:** The Program operation writes the contents of the OTP register permanently into the OTP ROM.
- **Analog Readback Operation:** The Analog Readback operation allows a quantifiable verification of the programming. For each programmed or unprogrammed bit, there is a representative analog value (in essence, a resistor value) that is read to verify whether a bit has been successfully programmed or not.

OTP Memory Assignment**Figure 33:
OTP Bit Assignment**

Bit	Symbol	Function	
	mbit1	Factory Bit 1	
51	Md0	Incremental output mode selection	Customer Section
50	Md1		
49	Div0		
48	Div1		
47	Index		
46	Z0	10-bit Zero Position	
:	:		
37	Z9		
36	CCW	Direction	
35	RA0	Redundancy Address	
:	:		
31	RA4		
30	FS 0	Factory Bit	Factory Section
:	:		
18	FS 12		
17	ChipID0	18-bit Chip ID	ID Section
16	ChipID1		
:	:		
0	ChipID17		
	mbit0	Factory Bit 0	

User Selectable Settings

The AS5140H allows programming of the following user selectable options:

- **Md1, Md0:** Incremental Output Mode Selection.
- **Div1, Div0:** Divider Setting of Incremental Output.
- **Index:** Index Pulse Width Selection – 1LSB / 3LSB.
- **Z [9:0]:** Programmable Zero / Index Position.

- **CCW:** Counter Clockwise Bit.
ccw=0 – angular value increases in clockwise direction.
ccw=1 – angular value increases in counterclockwise direction.
- **RA [4:0]:** Redundant Address. An OTP bit location addressed by this address is always set to “1” independent of the corresponding original OTP bit setting.

OTP Default Setting

The AS5140H can also be operated without programming. The default, un-programmed setting is as listed below.

- **Md0, MD1:00** = Incremental mode = quadrature.
- **Div0, Div1:00** = Incremental resolution = 10bit.
- **Index:0** = Index bit width = 1LSB.
- **Z9 to Z0:00** = No programmed zero position.
- **CCW:0** = Clockwise operation.
- **RA4 to RA0:0** = No OTP bit is selected.

Redundant Programming Option

In addition to the regular programming, a redundant programming option is available. This option allows that one selectable OTP bit can be set to “1” (programmed state) by writing the location of that bit into a 5-bit address decoder. This address can be stored in bits RA5...0 in the OTP user settings.

Example: Setting RA5 ...0 to “00001” will select bit 51 = MD0, “00010” selects bit 50 = MD1, “10000” selects bit 36 = CCW, etc.

OTP Register Entry and Exit Condition

To avoid accidental modification of the OTP during normal operation, each OTP access (Load, Write, Read, Program) requires a defined entry and exit procedure, using the CSn, PROG and CLK signals as shown in Figure 34.

Figure 34:
OTP Access Timing Diagram

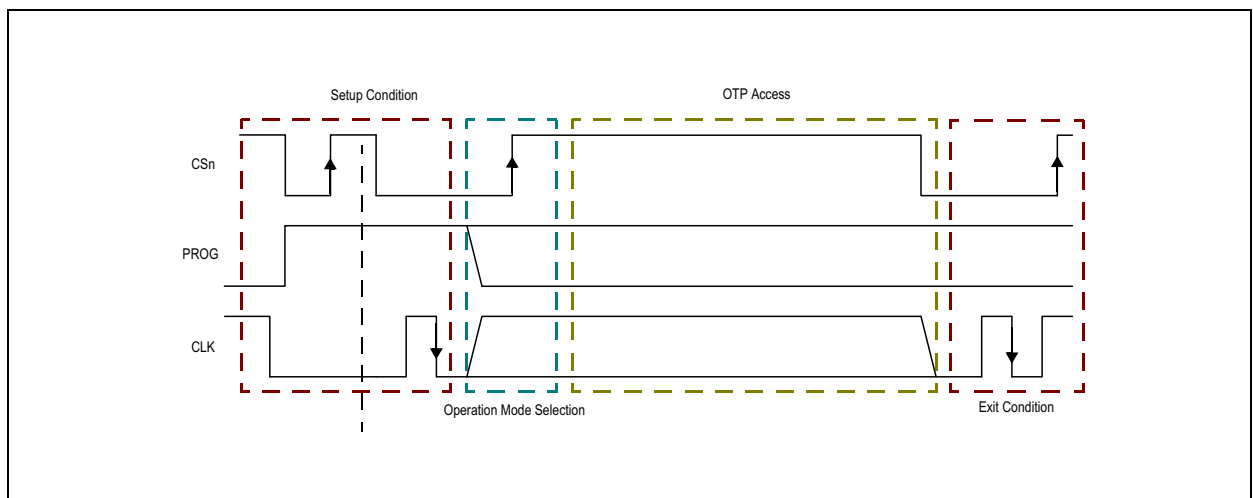

Incremental Mode Programming

The following three different incremental output modes are available:

- Mode: Md1=0 / Md0=1 sets the AS5140H in quadrature mode.
- Mode: Md1=1 / Md0=0 sets the AS5140H in step / direction mode (see [Figure 5](#)).

In both modes listed above, the incremental resolution may be reduced from 10 bit down to 9, 8 or 7 bit using the divider OTP bits Div1 and Div0 (see [Figure 35](#) below).

- Mode: Md1=1 / Md0=1 sets the AS5140H in brushless DC motor commutation mode with an additional LSB incremental signal at pin 12 (PWM_LSB).

To allow programming of all bits, the default factory setting is all bits = 0. This mode is equal to mode 1:0 (quadrature A/B, 1LSB index width, 256ppr). The absolute angular output value, by default, increases with clockwise rotation of the magnet (top view). Setting the CCW-bit (see [Figure 33](#)) allows for reversing the indicated direction, e.g. when the magnet is placed underneath the IC:

- CCW = 0 – angular value increases clockwise;
- CCW = 1 – angular value increases counterclockwise.

By default, the zero / index position pulse is one LSB wide. It can be increased to a three LSB wide pulse by setting the Index-bit of the OTP register. Further programming options (commutation modes) are available for brushless DC motor-control.

Md1 = Md0 = 1 changes the incremental output pins 3, 4 and 6 to a 3-phase commutation signal. Div1 defines the number of pulses per revolution for either a two-pole (Div1=0) or four-pole (Div1=1) rotor.

In addition, the LSB is available at pin 12 (the LSB signal replaces the PWM-signal), which allows for high rotational speed measurement of up to 10000 rpm.

Figure 35:
One Time Programmable (OTP) Register Options

Mode	OTP-Mode-Register-Bit					Pin#				Pulses Per Revolution (ppr)	Incremental Resolution (bit)
	Md1	Md0	Div1	Div0	Index	3	4	6	12		
default (Mode0.0) ⁽¹⁾	0	0	0	0	0	A	B	1LSB	PWM 10 bit	2x256	10
quadAB-Mode1.0	0	1	0	0	0			1LSB			
quadAB-Mode1.1	0	1	0	0	1			3LSBs			
quadAB-Mode1.2	0	1	0	1	0			1LSB		2x128	9
quadAB-Mode 1.3	0	1	0	1	1			3LSBs			
quadAB-Mode 1.4	0	1	1	0	0			1LSB		2x64	8
quadAB-Mode 1.5	0	1	1	0	1			3LSBs			
quadAB-Mode 1.6	0	1	1	1	0			1LSB		2x32	7
quadAB-Mode 1.7	0	1	1	1	1			3LSBs			

Mode	OTP-Mode-Register-Bit					Pin#				Pulses Per Revolution (ppr)	Incremental Resolution (bit)
	Md1	Md0	Div1	Div0	Index	3	4	6	12		
Step/Dir-Mode 2.0	1	0	0	0	0	LSB	Dir	1LSB	PWM 10 bit	512	10
Step/Dir-Mode 2.1	1	0	0	0	1			3LSBs			
Step/Dir-Mode 2.2	1	0	0	1	0			1LSB		256	9
Step/Dir-Mode 2.3	1	0	0	1	1			3LSBs			
Step/Dir-Mode 2.4	1	0	1	0	0			1LSB		128	8
Step/Dir-Mode 2.5	1	0	1	0	1			3LSBs			
Step/Dir-Mode 2.6	1	0	1	1	0			1LSB		64	7
Step/Dir-Mode 2.7	1	0	1	1	1			3LSBs			
Commutation-Mode3.0	1	1	0	0	0	U(0°)	V(120°)	W(240°)	LSB	3x1	10
Commutation-Mode3.1	1	1	0	1	0						9
Commutation-Mode3.2	1	1	1	0	0	U'(0°,180°)	V'(60°,240°)	W'(120°,300°)	LSB	2x3	10
Commutation-Mode3.3	1	1	1	1	0						9

Note(s) and/or Footnote(s):

1. Div1, Div0 and Index cannot be programmed in Mode 0:0.

Zero Position Programming

Zero position programming is an OTP option that simplifies assembly of a system, as the magnet does not need to be manually adjusted to the mechanical zero position. Once the assembly is completed, the mechanical and electrical zero positions can be matched by software. Any position within a full turn can be defined as the permanent new zero/index position. For zero position programming, the magnet is turned to the mechanical zero position (e.g. the "OFF"-position of a rotary switch) and the actual angular value is read.

Alignment Mode

The alignment mode simplifies centering the magnet over the center of the chip to gain maximum accuracy. Alignment mode can be enabled with the falling edge of CS_n while Prog = logic high (see [Figure 37](#)). The Data bits D9-D0 of the SSI change to a 10-bit displacement amplitude output. A high value indicates large X or Y displacement, but also higher absolute magnetic field strength. The magnet is properly aligned, when the difference between highest and lowest value over one full turn is at a minimum. Under normal conditions, a properly aligned magnet will result in a reading of less than 128 over a full turn. The MagINC_n and MagDEC_n indicators will be = 1 when the alignment mode reading is < 128.

At the same time, both hardware pins MagINC_n (#1) and MagDEC_n (#2) will be pulled to VSS. A properly aligned magnet will therefore produce a MagINC_n = MagDEC_n = 1 signal throughout a full 360° turn of the magnet. Stronger magnets or short gaps between magnet and IC may show values larger than 128. These magnets are still properly aligned as long as the difference between highest and lowest value over one full turn is at a minimum. The Alignment mode can be reset to normal operation by a power-on-reset (disconnect / re-connect power supply) or by a falling edge on CS_n with Prog = low.

Figure 36:
Enabling the Alignment Mode

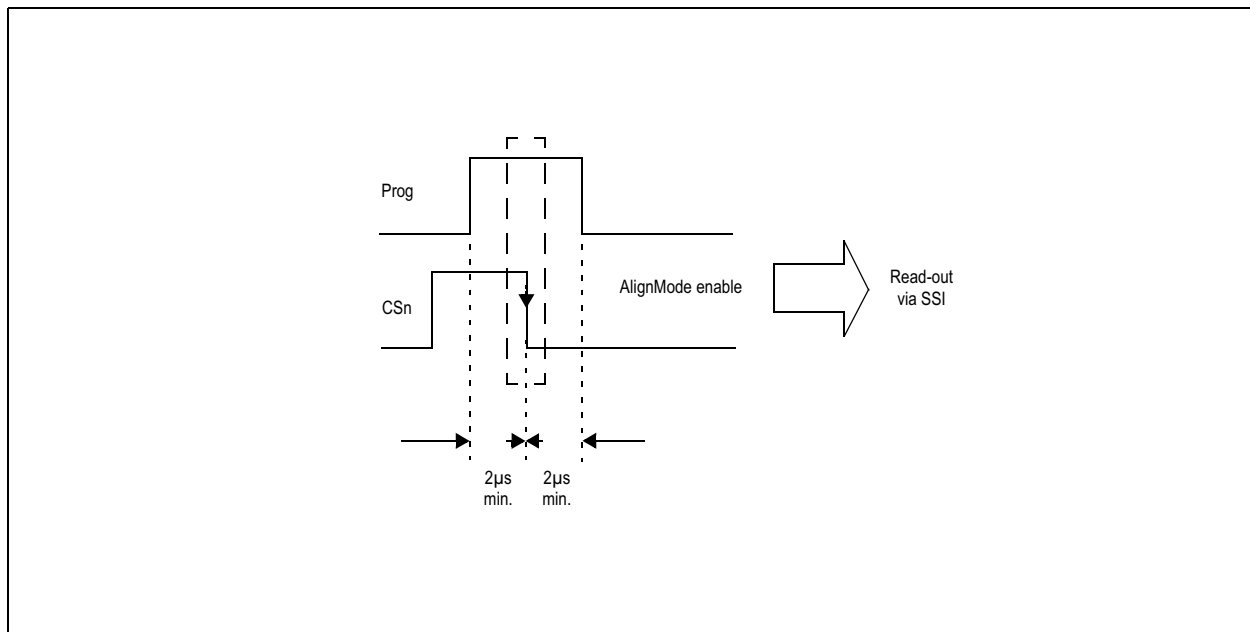
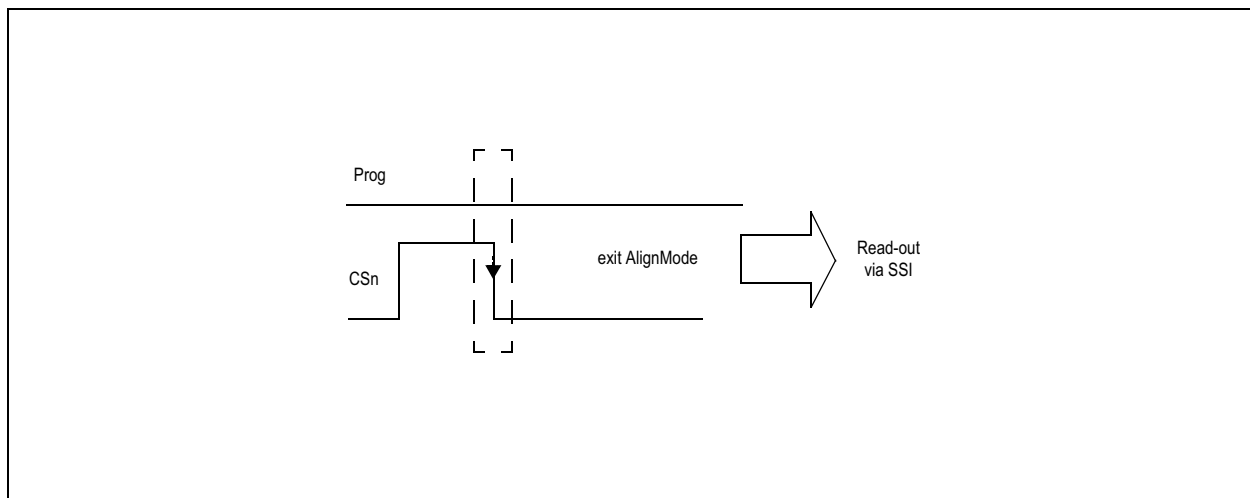

Figure 37:
Exiting Alignment Mode



3.3V / 5V Operation

The AS5140H operates either at 3.3V ±10% or at 5V ±10%. This is made possible by an internal 3.3V Low-Dropout (LDO) voltage regulator. The internal supply voltage is always taken from the output of the LDO, meaning that the internal blocks are always operating at 3.3V. For 3.3V operation, the LDO must be bypassed by connecting VDD3V3 with VDD5V (see [Figure 38](#)).

For 5V operation, the 5V supply is connected to pin VDD5V, while VDD3V3 (LDO output) must be buffered by a 2.2...10µF capacitor, which is supposed to be placed close to the supply pin (see [Figure 38](#)). The VDD3V3 output is intended for internal use only. It must not be loaded with an external load.

The output voltage of the digital interface I/O's corresponds to the voltage at pin VDD5V, as the I/O buffers are supplied from this pin (see Figure 38). A buffer capacitor of 100nF is recommended in both cases close to pin VDD5V.

Note that pin VDD3V3 must always be buffered by a capacitor. It must not be left floating, as this may cause an instable internal 3.3V supply voltage, which may lead to larger than normal jitter of the measured angle.

Figure 38:
Connections for 5V/3.3V Supply Voltages

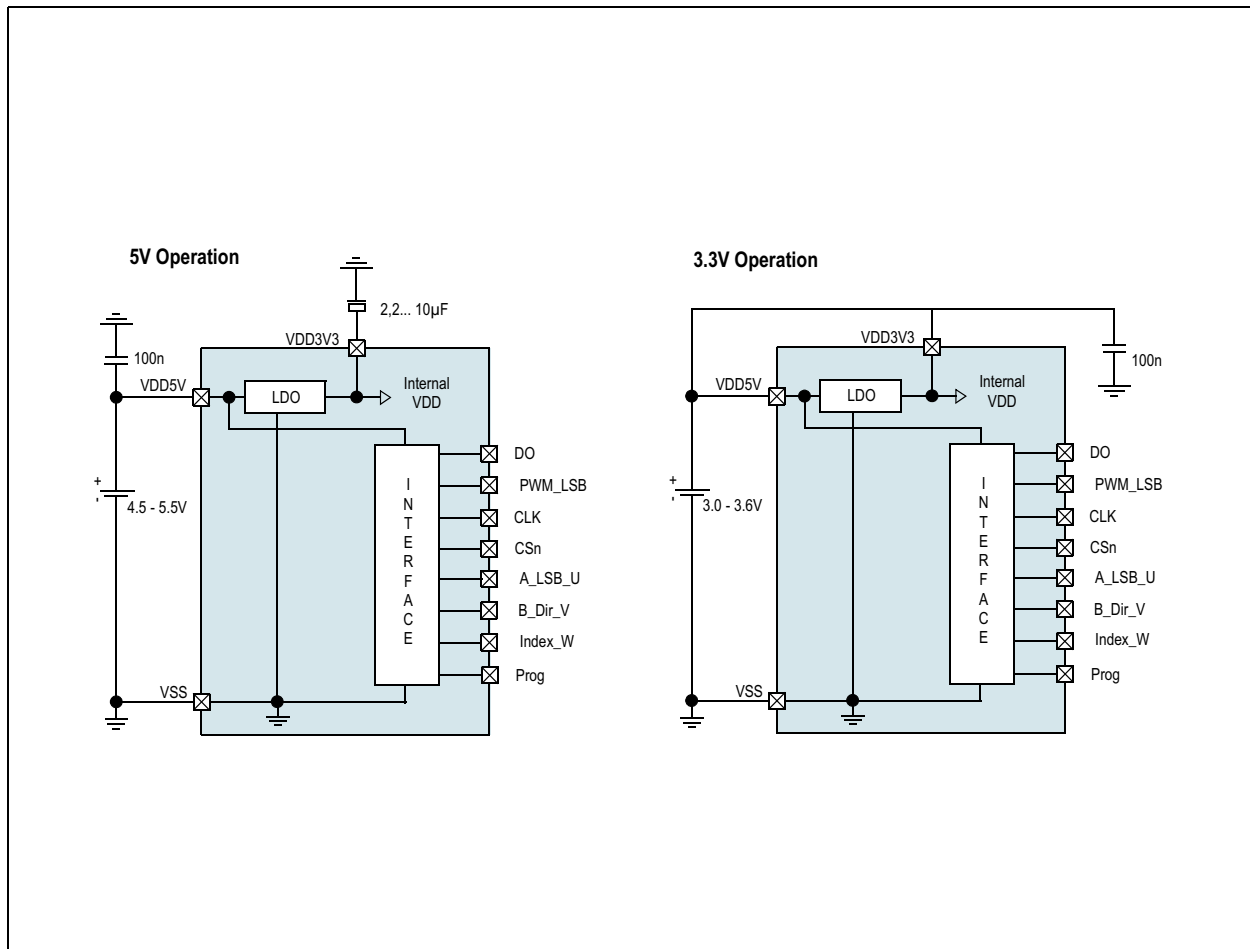

Choosing the Proper Magnet

Typically the magnet should be 6mm in diameter and ≥ 2.5 mm in height. Magnetic materials such as rare earth AlNiCo, SmCo5 or NdFeB are recommended. The magnet's field strength perpendicular to the die surface should be verified using a gaussmeter. The magnetic field B_v at a given distance, along a concentric circle with a radius of 1.1mm (R_1), should be in the range of ± 45 mT ... ± 75 mT. (see [Figure 39](#)).

Physical Placement of the Magnet

The best linearity can be achieved by placing the center of the magnet exactly over the defined center of the IC package as shown in [Figure 40](#).

Magnet Placement. The magnet's center axis should be aligned within a displacement radius R_d of 0.25mm from the defined center of the IC with reference to the edge of pin #1 (see [Figure 40](#)). This radius includes the placement tolerance of the chip within the SSOP-16 package (± 0.235 mm). The displacement radius R_d is 0.485mm with reference to the center of the chip (see [Alignment Mode](#)).

The vertical distance should be chosen such that the magnetic field on the die surface is within the specified limits (see [Figure 39](#)). The typical distance "z" between the magnet and the package surface is 0.5mm to 1.8mm with the recommended magnet (6mm x 2.5mm). Larger gaps are possible, as long as the required magnetic field strength stays within the defined limits. A magnetic field outside the specified range may still produce usable results, but the out-of-range condition will be indicated by MagINCn (pin 1) and MagDECn (pin 2), (see [Figure 22](#)).

Figure 39:
Typical Magnet and Magnetic Field Distribution

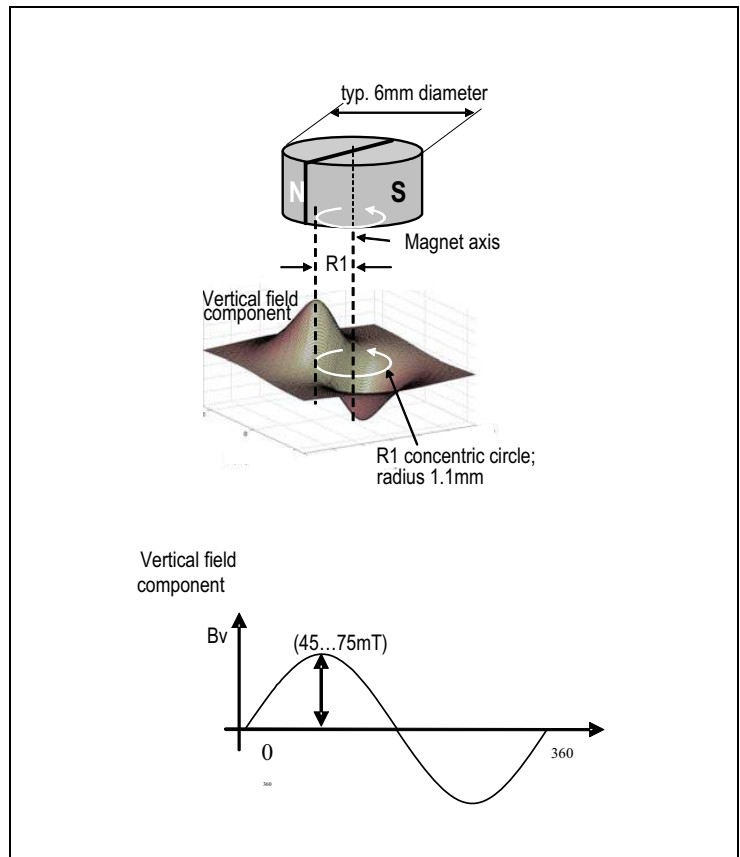

Figure 40:
Defined IC Center and Magnet Displacement Radius

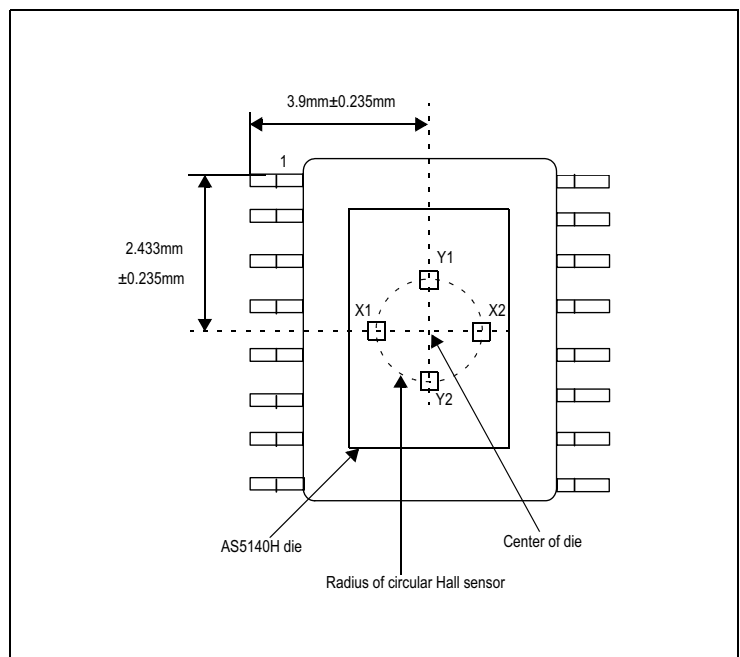
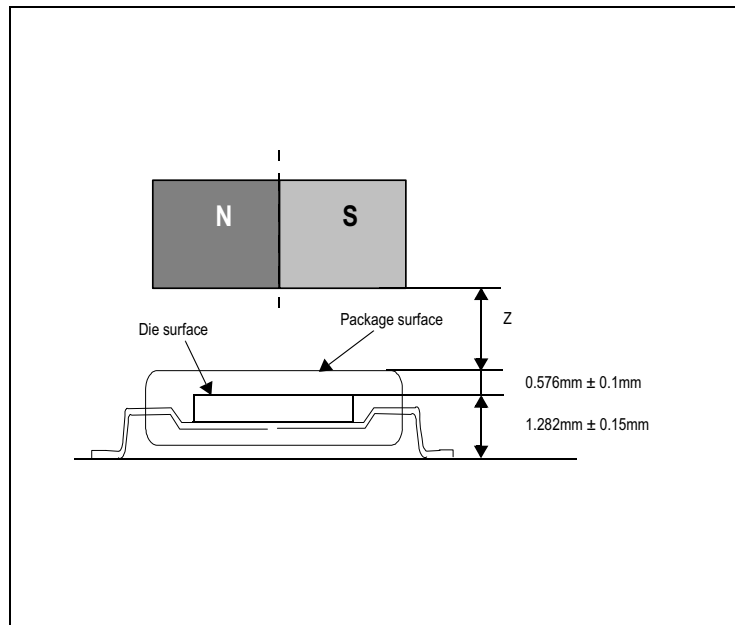

Figure 41:
Vertical Placement of the Magnet



Simulation Modeling

With reference to [Figure 42](#), a diametrically magnetized permanent magnet is placed above or below the surface of the AS5140H. The chip uses an array of Hall sensors to sample the vertical vector of a magnetic field distributed across the device package surface. The area of magnetic sensitivity is a circular locus of 1.1 mm radius with respect to the center of the die. The Hall sensors in the area of magnetic sensitivity are grouped and configured such that orthogonally related components of the magnetic fields are sampled differentially. The differential signal Y1-Y2 will give a sine vector of the magnetic field. The differential signal X1-X2 will give an orthogonally related cosine vector of the magnetic field.

Failure Diagnostics

The AS5140H also offers several diagnostic and failure detection features, which are discussed in detail further in the document.

Magnetic Field Strength Diagnosis

By Software: The MagINCn and MagDECn status bits will both be high when the magnetic field is out of range.

By Hardware: Pins #1 (MagINCn) and #2 (MagDECn) are open-drain outputs and will both be turned on (= low with external pull-up resistor) when the magnetic field is out of range. If only one of the outputs is low, the magnet is either moving towards the chip (MagINCn) or away from the chip (MagDECn).

Power Supply Failure Detection

By Software: If the power supply to the AS5140H is interrupted, the digital data read by the SSI will be all "0"s. Data is only valid, when bit OCF is high, hence a data stream with all "0"s is invalid. To ensure adequate low levels in the failure case, a pull-down resistor (~10kΩ) should be added between pin DO and VSS at the receiving side.

By Hardware: The MagINCn and MagDECn pins are open drain outputs and require external pull-up resistors. In normal operation, these pins are high ohmic and the outputs are high (see [Figure 22](#)). In a failure case, either when the magnetic field is out of range or the power supply is missing, these outputs will become low. To ensure adequate low levels in case of a broken power supply to the AS5140H, the pull-up resistors (>10kΩ) from each pin must be connected to the positive supply at pin 16 (VDD5V).

By Hardware - PWM Output: The PWM output is a constant stream of pulses with 1kHz repetition frequency. In case of power loss, these pulses are missing.

By Hardware - Incremental Outputs: In normal operation, pins A(#3), B(#4) and Index (#6) will never be high at the same time, as Index is only high when A=B=low. However, after a power-on-reset, if VDD is powered up or restarts after a power supply interruption, all three outputs will remain in high state until pin CSn is pulled low. If CSn is already tied to VSS during power-up, the incremental outputs will all be high until the internal offset compensation is finished (within t_{PwrUp}).

Angular Output Tolerances

Accuracy

Accuracy is defined as the error between the measured angle and the actual angle. It is influenced by several factors:

- The non-linearity of the analog-digital converters
- Internal gain and mismatch errors
- Non-linearity due to misalignment of the magnet

As a sum of all these errors, the accuracy with centered magnet = $(Err_{max} - Err_{min})/2$ is specified as better than ± 0.5 degrees @ 25°C (see Figure 44). Misalignment of the magnet further reduces the accuracy. Figure 43 shows an example of a 3D-graph displaying non-linearity over XY-misalignment. The center of the square XY-area corresponds to a centered magnet (see dot in the center of the graph). The X- and Y- axis extends to a misalignment of ± 1 mm in both directions. The total misalignment area of the graph covers a square of 2mm x 2mm (79mil x 79 mil) with a step size of 100 μ m. For each misalignment step, the measurement as shown in Figure 44 is repeated and the accuracy $(Err_{max} - Err_{min})/2$ (e.g. 0.25° in Figure 44) is entered as the Z-axis in the 3D-graph.

Figure 43:
Example of Linearity Error Over XY Misalignment

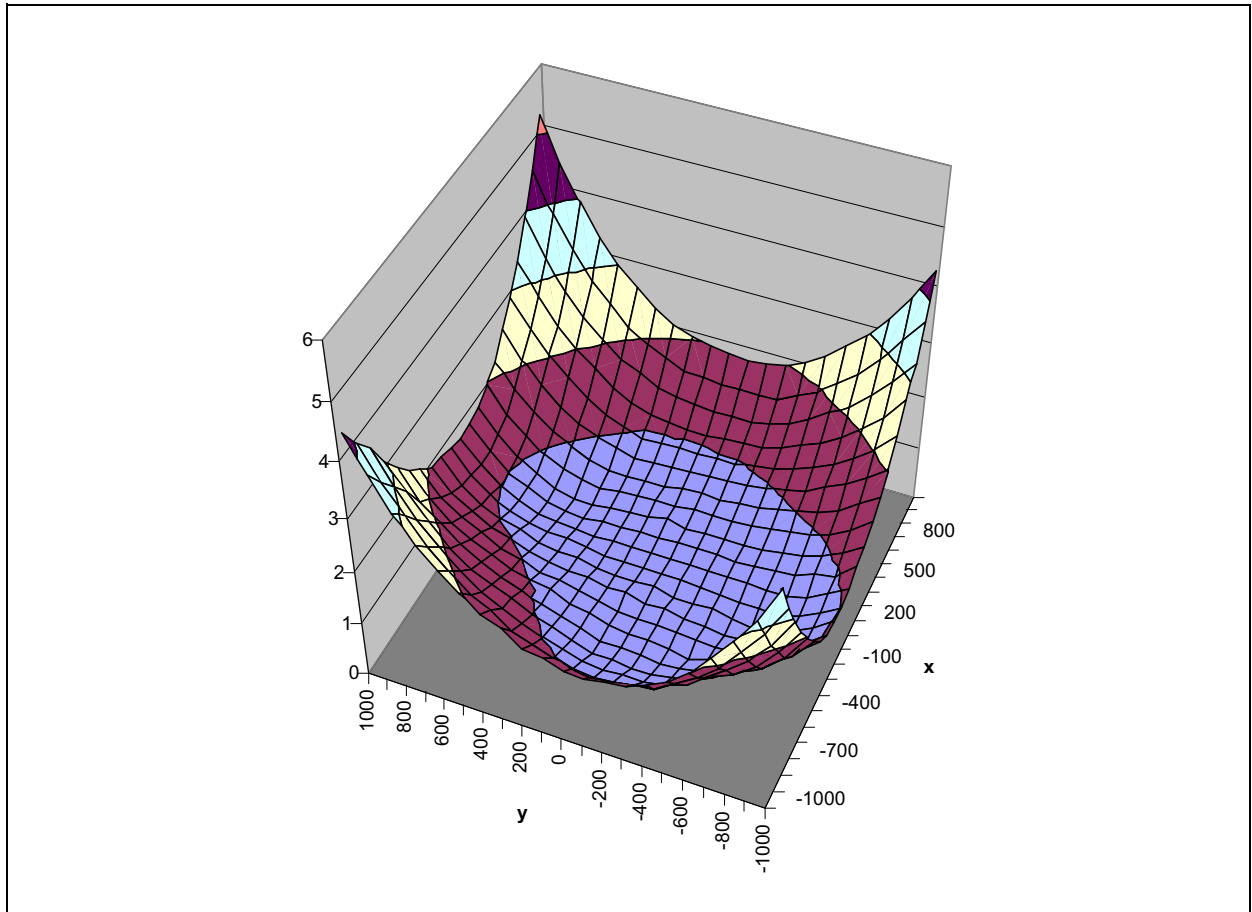

The maximum non-linearity error on this example is better than ± 1 degree (inner circle) over a misalignment radius of ~ 0.7 mm. For volume production, the placement tolerance of the IC within the package (± 0.235 mm) must also be taken into account. The total nonlinearity error over process tolerances, temperature and a misalignment circle radius of 0.25mm is specified better than ± 1.4 degrees.

Note(s): The magnet used for this measurement was a cylindrical NdFeB (Bomatec® BMN-35H) magnet with 6mm diameter and 2.5mm in height.

Figure 44:
Example of Linearity Error Over 360°

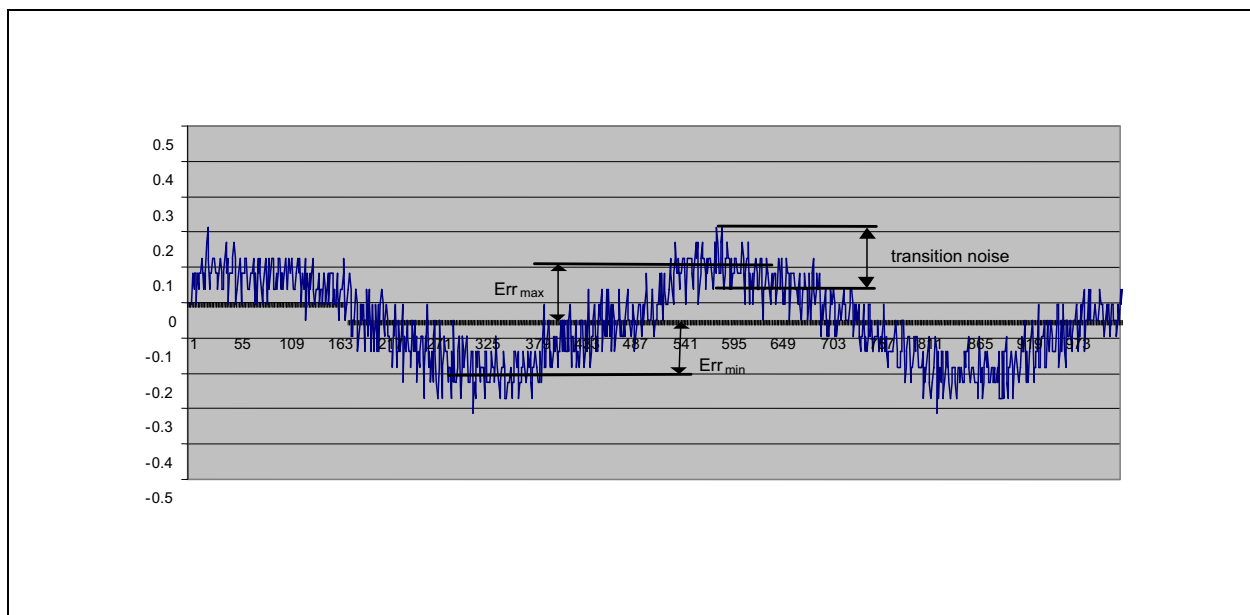

Transition Noise

Transition noise is defined as the jitter in the transition between two steps. Due to the nature of the measurement principle (Hall sensors + Preamplifier + ADC), there is always a certain degree of noise involved. This transition noise voltage results in an angular transition noise at the outputs. It is specified as 0.06 degrees rms (1 sigma)¹. This is the repeatability of an indicated angle at a given mechanical position.

The transition noise has different implications on the type of output that is used:

- **Absolute Output; SSI Interface:** The transition noise of the absolute output can be reduced by the user by applying an averaging of readings. An averaging of 4 readings will reduce the transition noise by 50% = 0.03° rms (1 sigma).

1. Statistically, 1 sigma represents 68.27% of readings; 3 sigma represents 99.73% of readings.

- **PWM Interface:** If the PWM interface is used as an analog output by adding a low pass filter, the transition noise can be reduced by lowering the cutoff frequency of the filter. If the PWM interface is used as a digital interface with a counter at the receiving side, the transition noise may again be reduced by averaging of readings.
- **Incremental Mode:** In incremental mode, the transition noise influences the period, width and phase shift of the output signals A, B and Index. However, the algorithm used to generate the incremental outputs guarantees no missing or additional pulses even at high speeds (up to 10000 rpm and higher).

High Speed Operation

The AS5140H samples the angular value at a rate of 10.42k samples per second. Consequently, the incremental and the absolute outputs are updated each by 96µs. At a stationary position of the magnet, this sampling rate creates no additional error.

Absolute Mode. With the given sampling rate of 10.4 kHz, the number of samples (n) per turn for a magnet rotating at high speed can be calculated by:

$$(EQ6) \quad n = \frac{60}{\text{rpm} \cdot 96\mu\text{s}}$$

In practice, there is no upper speed limit. The only restriction is that there will be fewer samples per revolution as the speed increases.

Regardless of the rotational speed, the absolute angular value is always sampled at the highest resolution of 10 bit. Likewise, for a given number of samples per revolution (n), the maximum speed can be calculated by:

$$(EQ7) \quad \text{rpm} = \frac{60}{n \cdot 96\mu\text{s}}$$

In absolute mode (serial interface and PWM output), 610 rpm is the maximum speed, where 1024 readings per revolution can be obtained. In incremental mode, the maximum error caused by the sampling rate of the ADCs is 0/+96µs. It has a peak of 1LSB = 0.35° at 610 rpm. At higher speeds, this error is reduced again due to interpolation and the output delay remains at 192µs as the DSP requires two sampling periods (2x96µs) to synthesize and redistribute any missing pulses.

Incremental Mode. Incremental encoders are usually required to produce no missing pulses up to several thousand rpm. Therefore, the AS5140H has a built-in interpolator, which ensures that there are no missing pulses at the incremental outputs for rotational speeds of up to 10000 rpm, even at the highest resolution of 10 bits (512 pulses per revolution).

Figure 45:
Speed Performance

Absolute Output Mode	Incremental Output Mode
610rpm = 1024 samples / turn	No missing pulses @ 10 bit resolution (512ppr): max. speed = 10000 rpm
122rpm = 512 samples / turn	
2441rpm = 256 samples / turn	
etc.	

Propagation Delays

The propagation delay is the delay between the time that a sample is taken until it is converted and available as angular data. This delay is 48µs for the absolute interface and 192µs for the incremental interface. Using the SSI interface for absolute data transmission, an additional delay must be considered, caused by the asynchronous sampling ($t=0\dots 1/fs$) and the time it takes the external control unit to read and process the data.

Angular Error Caused by Propagation Delay. A rotating magnet will therefore cause an angular error caused by the output delay. This error increases linearly with speed:

$$(EQ8) \quad e_{\text{sampling}} = \text{rpm} * 6 * \text{prop.delay}$$

Where:

e_{sampling} = angular error [°]

rpm = rotating speed [rpm]

prop.delay = propagation delay [seconds]

Note(s): Since the propagation delay is known, it can be automatically compensated by the control unit that is processing the data from the AS5140H, thus reducing the angular error caused by speed.

Internal Timing Tolerance

The AS5140H does not require an external ceramic resonator or quartz. All internal clock timings for the AS5140H are generated by an on-chip RC oscillator. This oscillator is factory trimmed to ±5% accuracy at room temperature (±10% over full temperature range). This tolerance influences the ADC sampling rate and the pulse width of the PWM output:

- **Absolute output; SSI interface:** A new angular value is updated every 100µs (typ.)
- **Incremental outputs:** The incremental outputs are updated every 100µs (typ.)

- **PWM output:** A new angular value is updated every 100µs (typ.). The PWM pulse timings T_{ON} and T_{OFF} also have the same tolerance as the internal oscillator. If only the PWM pulse width T_{ON} is used to measure the angle, the resulting value also has this timing tolerance. However, this tolerance can be cancelled by measuring both T_{ON} and T_{OFF} and calculating the angle from the duty cycle (see [Pulse Width Modulation \(PWM\) Output](#)):

$$(EQ9) \quad \text{Position} = \frac{t_{ON} \cdot 1025}{(t_{ON} + t_{OFF})} - 1$$

Temperature

Magnetic Temperature Coefficient. One of the major benefits of the AS5140H, in comparison to linear Hall sensors is that it is much less sensitive to temperature. While linear Hall sensors require a compensation of the magnet's temperature coefficient, the AS5140H automatically compensates for the varying magnetic field strength over temperature. The magnet's temperature drift does not need to be considered, as the AS5140H operates with magnetic field strengths from ±45 ... ±75mT.

Example:

A NdFeB magnet has a field strength of 75mT @ -40°C and a temperature coefficient of -0.12% per Kelvin. The temperature change is from -40°C to 150°C = 190K. The magnetic field change is: 190 x -0.12% = -22.8%, which corresponds to 75mT at -40°C and 57.9mT at 150°C.

In the above described scenario, the AS5140H can automatically compensate for the change in temperature related field strength. No user adjustment is required.

Accuracy Over Temperature. The influence of temperature in the absolute accuracy is very low. While the accuracy is $\leq \pm 0.5^\circ$ at room temperature, it may increase to $\leq \pm 0.9^\circ$ due to increasing noise at high temperatures.

Timing Tolerance Over Temperature. The internal RC oscillator is factory trimmed to $\pm 5\%$. Over temperature, this tolerance may increase to $\pm 10\%$. Generally, the timing tolerance has no influence in the accuracy or resolution of the system, as it is used mainly for internal clock generation. The only concern to the user is the width of the PWM output pulse, which relates directly to the timing tolerance of the internal oscillator. This influence however can be cancelled by measuring the complete PWM duty cycle (see [Internal Timing Tolerance](#)).

Application Information

The benefits of AS5140H are as follows:

- Complete system-on-chip
- Flexible system solution provides absolute, PWM and incremental outputs simultaneously
- Ideal for applications in harsh environments due to contactless position sensing
- Tolerant to magnet misalignment and airgap variations
- Tolerant to external magnetic fields
- Operates up to 150°C ambient temperature
- No temperature compensation necessary
- No calibration required
- 10, 9, 8 or 7-bit user programmable resolution
- Small Pb-free package: SSOP 16 (5.3mm x 6.2mm)

AS5140H Differences to AS5040

The AS5140H and AS5040 differ in the following features:

Figure 46:
Differences Between AS5140H and AS5040

Parameter	AS5140H	AS5040
Pin - assignment	Pin - compatible	
Ambient temperature range	-40°C ... 150°C	-40°C ... 125°C
Alignment mode	Exit alignment mode by power-on-reset, Exit alignment mode by POR or with PROG=low @ falling edge of CSn.	Exit alignment mode by power-on-reset only.
OTP programming voltage	3.0V to 3.6V	7.3V to 7.5V
OTP programming options	Incremental modes (quad AB, step/dir, BLDC) Incremental resolution Incremental Index bit width 10-bit Zero position Direction bit (cw/ccw) Redundancy address (1 of 16) 18-bit Chip-Identifier	Incremental modes (quad AB, step/dir, BLDC) Incremental resolution Incremental Index bit width 10-bit Zero position Direction bit (cw/ccw)
OTP programming protocol	CSn, Prog and CLK; 52-bit serial data protocol	CSn, Prog and CLK; 16-bit (32-bit) serial data protocol

Package Drawings & Markings

The device is available in a 16-Lead Shrink Small Outline Package.

Figure 47:
Package Drawings and Dimensions

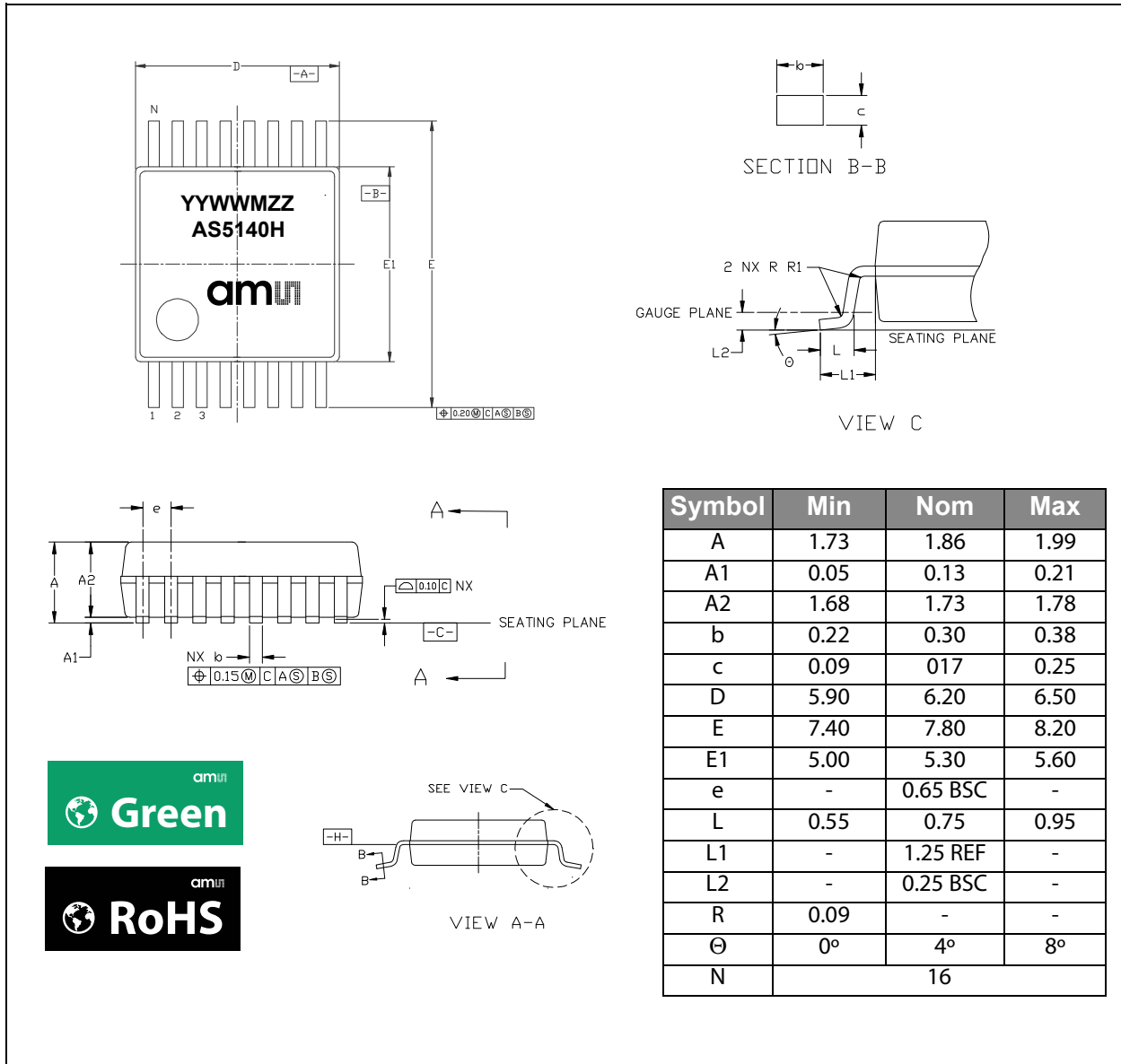

Note(s) and/or Footnote(s):

1. Dimensions and tolerancing conform to ASME Y14.5M-1994.
2. All dimensions are in millimeters. Angles are in degrees.

Figure 48:
Package Marking: YYWWMZZ

YY	WW	M	ZZ
Last two digits of the manufacturing year	Manufacturing week	Plant identifier	Assembly traceability code

Figure 49:
Vertical Cross Section of SSOP-16

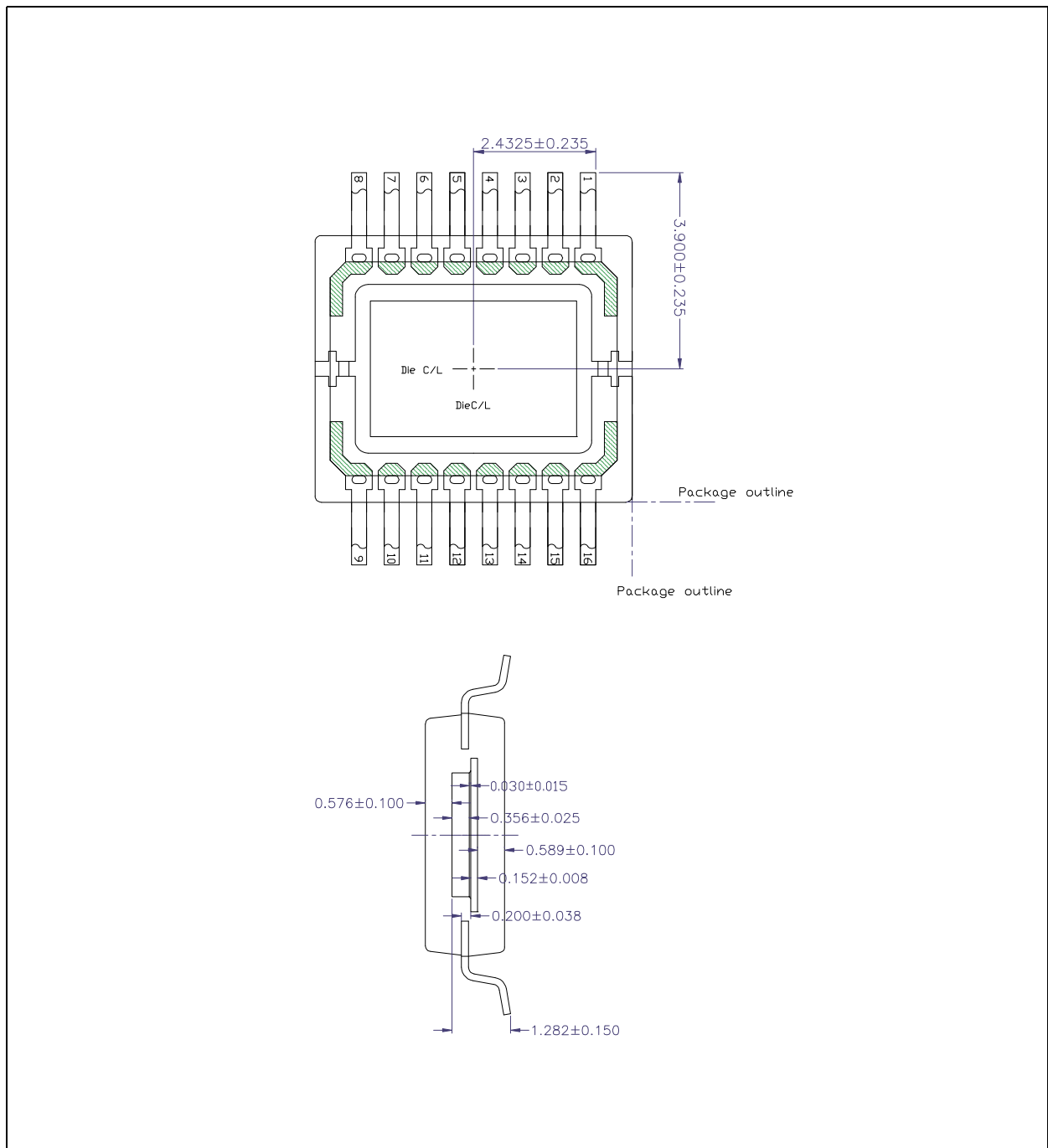

Recommended PCB Footprint

Figure 50:
PCB Footprint

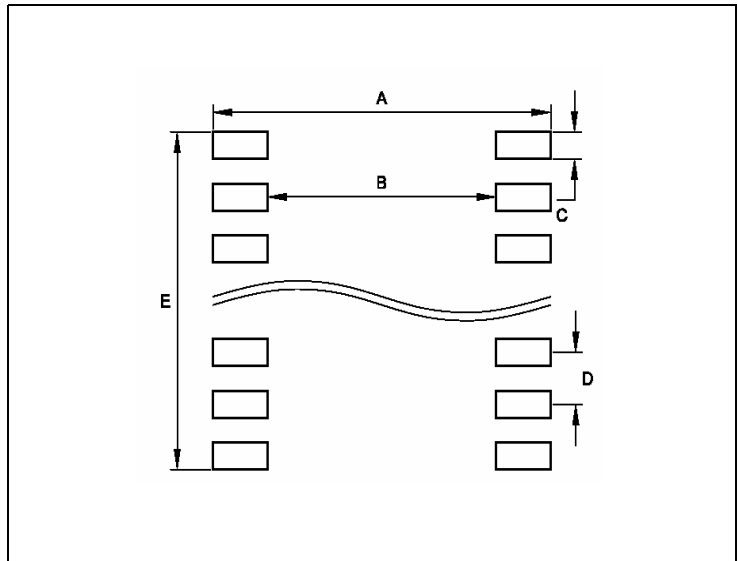

Figure 51:
Recommended Footprint Data

Symbol	mm	inch
A	9.02	0.355
B	6.16	0.242
C	0.46	0.018
D	0.65	0.025
E	5.01	0.197

Ordering & Contact Information

The devices are available as the standard products shown in [Figure 52](#).

Figure 52:
Ordering Information

Ordering Code	Package	Marking	Delivery Form	Delivery Quantity
AS5140H-ASST	SSOP-16	AS5140H	Tape & Reel	2000 pcs/reel
AS5140H-ASSM	SSOP-16	AS5140H	Tape & Reel	500 pcs/reel

Buy our products or get free samples online at:

www.ams.com/ICdirect

Technical Support is available at:

www.ams.com/Technical-Support

Provide feedback about this document at:

www.ams.com/Document-Feedback

For further information and requests, e-mail us at:

ams_sales@ams.com

For sales offices, distributors and representatives, please visit:

www.ams.com/contact

Headquarters

ams AG

Tobelbader Strasse 30

8141 Premstaetten

Austria, Europe

Tel: +43 (0) 3136 500 0

Website: www.ams.com

RoHS Compliant & ams Green Statement

RoHS: The term RoHS compliant means that ams AG products fully comply with current RoHS directives. Our semiconductor products do not contain any chemicals for all 6 substance categories, including the requirement that lead not exceed 0.1% by weight in homogeneous materials. Where designed to be soldered at high temperatures, RoHS compliant products are suitable for use in specified lead-free processes.

ams Green (RoHS compliant and no Sb/Br): ams Green defines that in addition to RoHS compliance, our products are free of Bromine (Br) and Antimony (Sb) based flame retardants (Br or Sb do not exceed 0.1% by weight in homogeneous material).

Important Information: The information provided in this statement represents ams AG knowledge and belief as of the date that it is provided. ams AG bases its knowledge and belief on information provided by third parties, and makes no representation or warranty as to the accuracy of such information. Efforts are underway to better integrate information from third parties. ams AG has taken and continues to take reasonable steps to provide representative and accurate information but may not have conducted destructive testing or chemical analysis on incoming materials and chemicals. ams AG and ams AG suppliers consider certain information to be proprietary, and thus CAS numbers and other limited information may not be available for release.

Copyrights & Disclaimer

Copyright ams AG, Tobelbader Strasse 30, 8141 Premstaetten, Austria-Europe. Trademarks Registered. All rights reserved. The material herein may not be reproduced, adapted, merged, translated, stored, or used without the prior written consent of the copyright owner.

Devices sold by ams AG are covered by the warranty and patent indemnification provisions appearing in its General Terms of Trade. ams AG makes no warranty, express, statutory, implied, or by description regarding the information set forth herein. ams AG reserves the right to change specifications and prices at any time and without notice. Therefore, prior to designing this product into a system, it is necessary to check with ams AG for current information. This product is intended for use in commercial applications. Applications requiring extended temperature range, unusual environmental requirements, or high reliability applications, such as military, medical life-support or life-sustaining equipment are specifically not recommended without additional processing by ams AG for each application. This product is provided by ams AG "AS IS" and any express or implied warranties, including, but not limited to the implied warranties of merchantability and fitness for a particular purpose are disclaimed.

ams AG shall not be liable to recipient or any third party for any damages, including but not limited to personal injury, property damage, loss of profits, loss of use, interruption of business or indirect, special, incidental or consequential damages, of any kind, in connection with or arising out of the furnishing, performance or use of the technical data herein. No obligation or liability to recipient or any third party shall arise or flow out of ams AG rendering of technical or other services.

Document Status

Document Status	Product Status	Definition
Product Preview	Pre-Development	Information in this datasheet is based on product ideas in the planning phase of development. All specifications are design goals without any warranty and are subject to change without notice
Preliminary Datasheet	Pre-Production	Information in this datasheet is based on products in the design, validation or qualification phase of development. The performance and parameters shown in this document are preliminary without any warranty and are subject to change without notice
Datasheet	Production	Information in this datasheet is based on products in ramp-up to full production or full production which conform to specifications in accordance with the terms of ams AG standard warranty as given in the General Terms of Trade
Datasheet (discontinued)	Discontinued	Information in this datasheet is based on products which conform to specifications in accordance with the terms of ams AG standard warranty as given in the General Terms of Trade, but these products have been superseded and should not be used for new designs

Revision Information

Changes from 1-08 (2015-Jan-16) to current revision 1-09 (2018-Feb-20)	Page
Updated Figure 35	30

Note(s) and/or Footnote(s):

1. Page and figure numbers for the previous version may differ from page and figure numbers in the current revision.
2. Correction of typographical errors is not explicitly mentioned.

Content Guide

1	General Description
1	Key Benefits & Features
2	Applications
2	Block Diagram
3	Pin Assignment
3	Pin Description
6	Absolute Maximum Ratings
7	Electrical Characteristics
7	DC Characteristics for Digital Inputs and Outputs
9	Magnetic Input Specification
10	Electrical System Specifications
12	Programming Conditions
13	Timing Characteristics
15	Detailed Description
16	10-Bit Absolute Angular Position Output
16	Synchronous Serial Interface (SSI)
18	Daisy Chain Mode
20	Incremental Outputs
20	Quadrature A/B Output (Quad A/B Mode)
21	LSB Output (Step/Direction Mode)
21	Incremental Output Hysteresis
22	Pulse Width Modulation (PWM) Output
23	Analog Output
24	Brushless DC Motor Commutation Mode
25	Programming the AS5140H
27	OTP Memory Assignment
27	User Selectable Settings
28	OTP Default Setting
28	Redundant Programming Option
28	OTP Register Entry and Exit Condition
29	Incremental Mode Programming
32	Zero Position Programming
32	Alignment Mode
33	3.3V / 5V Operation
35	Choosing the Proper Magnet
35	Physical Placement of the Magnet
37	Simulation Modeling
39	Failure Diagnostics
39	Magnetic Field Strength Diagnosis
39	Power Supply Failure Detection
40	Angular Output Tolerances
40	Accuracy
41	Transition Noise
42	High Speed Operation
43	Propagation Delays
43	Internal Timing Tolerance
44	Temperature

45	Application Information
45	AS5140H Differences to AS5040
46	Package Drawings & Markings
47	Recommended PCB Footprint
48	Ordering & Contact Information
49	RoHS Compliant & ams Green Statement
50	Copyrights & Disclaimer
51	Document Status
52	Revision Information