



### FEATURES:

- TCR as low as  $\pm 25\text{ppm}$
- Higher operating frequency with less parasitics
- Noise characteristics superior to standard thick film resistors
- Reference standards of EIA JIS C 5201-1
- Tolerance as low as  $\pm 0.1\%$



### PART NUMBER STRUCTURE

TFCR Series	1206 Size	8W Power Rating	E TCR	1001 Resistance Value	B Resistance Tolerance	T Packaging	M Optional Reel Identifier
0201	32W = 0.03W	E = $\pm 25\text{ppm}/^\circ\text{C}$	1001 = $1\text{K}\Omega$	B = $\pm 0.1\%$	T = Tape & Reel	Leave blank for standard quantity.  Add "-1K" if 1000 piece reel is required	
0402	20W = 0.05W	C = $\pm 50\text{ppm}/^\circ\text{C}$	4 digit code e.g. 4R70 = $4.7\Omega$	C = $\pm 0.25\%$			
0603	16W = 0.063W	K = $\pm 100\text{ppm}/^\circ\text{C}$	1001 = $1\text{K}\Omega$	D = $\pm 0.50\%$			
0805	10W = 0.10W		2494 = $2.49\text{M}\Omega$	F = $\pm 1\%$			
1206	8W = 0.125W						
1210	4W = 0.25W						
2010	2W = 0.50W						
2512							

Example P/N: TFCR1206-8W-E-1001BT

Standard Termination is 100% matte Tin over Nickel.

### DIMENSIONS

Unit: inches (mm)

SIZE	L	W	T	l1	l2
0201	$0.023 \pm 0.001$ (0.60 $\pm$ 0.03)	$0.011 \pm 0.001$ (0.30 $\pm$ 0.03)	$0.009 \pm 0.001$ (0.23 $\pm$ 0.03)	$0.006 \pm 0.002$ (0.15 $\pm$ 0.05)	$0.006 \pm 0.002$ (0.15 $\pm$ 0.05)
0402	$0.040 \pm 0.002$ (1.0 $\pm$ 0.05)	$0.019 \pm 0.002$ (0.5 $\pm$ 0.05)	$0.012 \pm 0.002$ (0.30 $\pm$ 0.05)	$0.008 \pm 0.004$ (0.2 $\pm$ 0.10)	$0.008 \pm 0.004$ (0.2 $\pm$ 0.10)
0603	$0.061 \pm 0.004$ (1.55 $\pm$ 0.10)	$0.031 \pm 0.004$ (0.8 $\pm$ 0.1)	$0.018 \pm 0.004$ (0.45 $\pm$ 0.10)	$0.012 \pm 0.008$ (0.30 $\pm$ 0.20)	$0.012 \pm 0.008$ (0.30 $\pm$ 0.20)
0805	$0.079 \pm 0.006$ (2.0 $\pm$ 0.15)	$0.049 \pm 0.006$ (1.25 $\pm$ 0.15)	$0.022 \pm 0.004$ (0.55 $\pm$ 0.10)	$0.012 \pm 0.008$ (0.30 $\pm$ 0.20)	$0.016 \pm 0.010$ (0.40 $\pm$ 0.25)
1206	$0.120 \pm 0.006$ (3.05 $\pm$ 0.15)	$0.061 \pm 0.006$ (1.55 $\pm$ 0.15)	$0.022 \pm 0.004$ (0.55 $\pm$ 0.10)	$0.017 \pm 0.008$ (0.42 $\pm$ 0.20)	$0.014 \pm 0.010$ (0.35 $\pm$ 0.25)
1210	$0.122 \pm 0.006$ (3.10 $\pm$ 0.15)	$0.094 \pm 0.006$ (2.40 $\pm$ 0.15)	$0.022 \pm 0.004$ (0.55 $\pm$ 0.10)	$0.016 \pm 0.008$ (0.40 $\pm$ 0.20)	$0.022 \pm 0.010$ (0.55 $\pm$ 0.25)
2010	$0.193 \pm 0.006$ (4.90 $\pm$ 0.15)	$0.094 \pm 0.006$ (2.40 $\pm$ 0.15)	$0.022 \pm 0.004$ (0.55 $\pm$ 0.10)	$0.024 \pm 0.012$ (0.60 $\pm$ 0.30)	$0.020 \pm 0.010$ (0.50 $\pm$ 0.25)
2512	$0.248 \pm 0.006$ (6.30 $\pm$ 0.15)	$0.122 \pm 0.006$ (3.10 $\pm$ 0.15)	$0.022 \pm 0.004$ (0.55 $\pm$ 0.10)	$0.024 \pm 0.012$ (0.60 $\pm$ 0.30)	$0.020 \pm 0.010$ (0.50 $\pm$ 0.25)

### STRUCTURE

1	Alumina Substrate	5	Nickel Plating
2	Backside Electrode	6	Tin Plating
3	Top Electrode	7	Resistive layer
4	Edge Electrode	8	Overcoat

### ELECTRICAL SPECIFICATION & RANGE

SIZE	0201		0402	0603		0805		1206		1210	2010	2512	
Power Rating at 70°C (W)	0.03W (1/32W)	0.05W (1/20W)	0.063W (1/16W)	0.063W (1/16W)	0.10W (1/10W)	0.10W (1/10W)	0.125W (1/8W)	0.125W (1/8W)	0.25W (1/4W)	0.25W (1/4W)	0.25W (1/4W)	0.50W (1/2W)	
Max. Working Voltage	15V		25V	50V		100V		150V		150V	150V	150V	
Max. Overload Voltage	30V		50V	100V		200V		300V		300V	300V	300V	
Operating Temp. Range	-55°C to +125°C		-55°C to +155°C	-55°C to +155°C		-55°C to +155°C		-55°C to +155°C		-55°C to +155°C	-55°C to +155°C	-55°C to +155°C	
Tolerance	TCR	Resistance Range		Resistance Range	Resistance Range		Resistance Range		Resistance Range	Resistance Range	Resistance Range	Resistance Range	
±0.1% (B)	±25ppm	22Ω - 75KΩ	22Ω - 75KΩ	10Ω - 511KΩ	4.7Ω - 1MΩ		4.7Ω - 2MΩ	4.7Ω - 1MΩ	4.7Ω - 2.49MΩ	4.7Ω - 1MΩ	4.7Ω - 2.49MΩ	4.7Ω - 3MΩ	4.7Ω - 3MΩ
	±50ppm	22Ω - 75KΩ	22Ω - 75KΩ	10Ω - 511KΩ	4.7Ω - 1MΩ		4.7Ω - 2MΩ	4.7Ω - 1MΩ	4.7Ω - 2.49MΩ	4.7Ω - 1MΩ	4.7Ω - 2.49MΩ	4.7Ω - 3MΩ	4.7Ω - 3MΩ
	±100ppm	22Ω - 75KΩ	22Ω - 75KΩ	10Ω - 511KΩ	4.7Ω - 1MΩ		4.7Ω - 2MΩ	4.7Ω - 1MΩ	4.7Ω - 2.49MΩ	4.7Ω - 1MΩ	4.7Ω - 2.49MΩ	4.7Ω - 3MΩ	4.7Ω - 3MΩ
±0.25% (C)	±25ppm	22Ω - 75KΩ	22Ω - 75KΩ	4.7Ω - 511KΩ	1Ω - 1MΩ	4.7Ω - 1MΩ	1Ω - 2MΩ	1Ω - 1MΩ	1Ω - 2.49MΩ	4.7Ω - 1MΩ	1Ω - 2.49MΩ	1Ω - 3MΩ	1Ω - 3MΩ
	±50ppm	22Ω - 75KΩ	22Ω - 75KΩ	4.7Ω - 511KΩ	1Ω - 1MΩ	4.7Ω - 1MΩ	1Ω - 2MΩ	1Ω - 1MΩ	1Ω - 2.49MΩ	4.7Ω - 1MΩ	1Ω - 2.49MΩ	1Ω - 3MΩ	1Ω - 3MΩ
	±100ppm	22Ω - 75KΩ	22Ω - 75KΩ	4.7Ω - 511KΩ	1Ω - 1MΩ	4.7Ω - 1MΩ	1Ω - 2MΩ	1Ω - 1MΩ	1Ω - 2.49MΩ	4.7Ω - 1MΩ	1Ω - 2.49MΩ	1Ω - 3MΩ	1Ω - 3MΩ
±0.5% (D)	±25ppm	22Ω - 75KΩ	22Ω - 75KΩ	4.7Ω - 511KΩ	1Ω - 1MΩ	4.7Ω - 1MΩ	1Ω - 2MΩ	1Ω - 1MΩ	1Ω - 2.49MΩ	4.7Ω - 1MΩ	1Ω - 2.49MΩ	1Ω - 3MΩ	1Ω - 3MΩ
	±50ppm	22Ω - 75KΩ	22Ω - 75KΩ	4.7Ω - 511KΩ	1Ω - 1MΩ	4.7Ω - 1MΩ	1Ω - 2MΩ	1Ω - 1MΩ	1Ω - 2.49MΩ	4.7Ω - 1MΩ	1Ω - 2.49MΩ	1Ω - 3MΩ	1Ω - 3MΩ
	±100ppm	22Ω - 75KΩ	22Ω - 75KΩ	4.7Ω - 511KΩ	1Ω - 1MΩ	4.7Ω - 1MΩ	1Ω - 2MΩ	1Ω - 1MΩ	1Ω - 2.49MΩ	4.7Ω - 1MΩ	1Ω - 2.49MΩ	1Ω - 3MΩ	1Ω - 3MΩ
±1% (F)	±25ppm	22Ω - 75KΩ	22Ω - 75KΩ	4.7Ω - 511KΩ	1Ω - 1MΩ	4.7Ω - 1MΩ	1Ω - 2MΩ	1Ω - 1MΩ	1Ω - 2.49MΩ	4.7Ω - 1MΩ	1Ω - 2.49MΩ	1Ω - 3MΩ	1Ω - 3MΩ
	±50ppm	22Ω - 75KΩ	22Ω - 75KΩ	4.7Ω - 511KΩ	1Ω - 1MΩ	4.7Ω - 1MΩ	1Ω - 2MΩ	1Ω - 1MΩ	1Ω - 2.49MΩ	4.7Ω - 1MΩ	1Ω - 2.49MΩ	1Ω - 3MΩ	1Ω - 3MΩ
	±100ppm	22Ω - 75KΩ	22Ω - 75KΩ	4.7Ω - 511KΩ	1Ω - 1MΩ	4.7Ω - 1MΩ	1Ω - 2MΩ	1Ω - 1MΩ	1Ω - 2.49MΩ	4.7Ω - 1MΩ	1Ω - 2.49MΩ	1Ω - 3MΩ	1Ω - 3MΩ

NOTE: Max Working Voltage is listed above or  $\sqrt{P \cdot R}$ , whichever is lower. Max overload Voltage is listed above or  $2.5 \cdot \sqrt{P \cdot R}$ , whichever is lower.

### MARKING CODE



- E-24 values for 0603 size maybe marked with the standard 3 digit marking code.
- E-96 values for 0805 size and larger, will be marked with standard 4 digit marking code.
- E-24 values for 0603 size and larger, will be marked with standard 3 digit marking code.
- 0603 - E-96 values will be marked with a standard 3 digit alpha numeric code

Please see 0603 marking codes PDF.

Note: 0201 and 0402 cannot be marked.

### DERATING CURVE

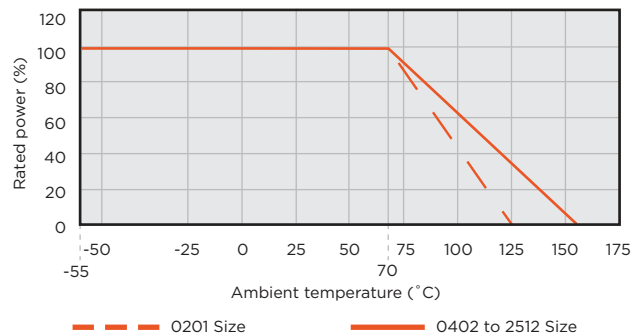

### REEL SPECIFICATIONS

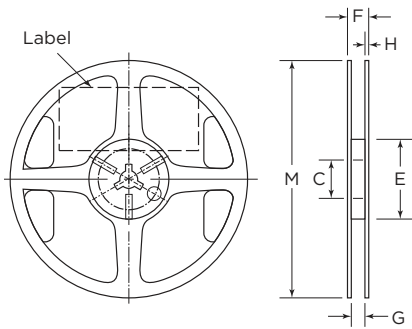

Unit: mm (inch)

C	E	F	G	H	M
13.0 ± 0.2 (0.51 ± 0.008)	60.0 ± 1.0 (2.36 ± 0.03)	11.4 ± 1.0 (0.45 ± 0.04)	9.0 ± .3 (0.35 ± 0.012)	1.5 ± .3 (0.06 ± 0.012)	180 ± 2.0 (7.09 ± 0.08)

Minimum of 30 empty pockets at the beginning of reel, 65 minimum empty pockets at the end.

### TAPE SPECIFICATIONS

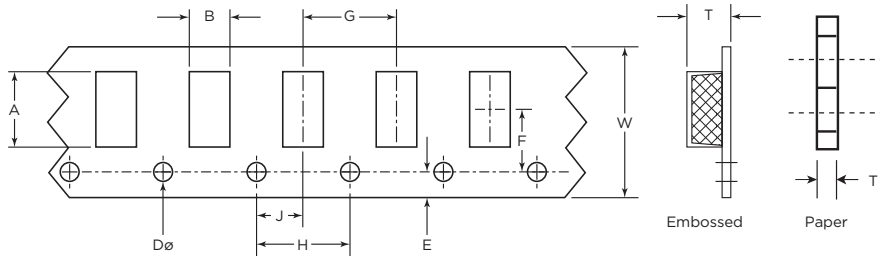

Units: mm

TAPE	SIZE (in)	A	B	W	E	F	T	G	H	J	Dø
Paper	0201	0.70±0.05	0.40±0.05	8.0±0.10	1.75±0.05	3.50±0.05	0.42±0.02	2.00±0.05	4.00±0.10	2.00±0.05	1.55±0.03
	0402	1.16±0.10	0.70±0.10	8.0±0.10	1.75±0.05	3.50±0.05	0.40±0.03	2.00±0.05	4.00±0.10	2.00±0.05	1.55±0.05
	0603	1.90±0.10	1.10±0.05	8.0±0.10	1.75±0.05	3.50±0.05	0.60±0.03	4.00±0.10	4.00±0.10	2.00±0.05	1.55±0.05
	0805	2.37±0.20	1.60±0.05	8.0±0.10	1.75±0.05	3.50±0.05	0.75±0.05	4.00±0.10	4.00±0.10	2.00±0.05	1.55±0.05
	1206	3.55±0.05	2.00±0.05	8.0±0.10	1.75±0.05	3.50±0.05	0.75±0.05	4.00±0.10	4.00±0.10	2.00±0.05	1.55±0.05
	1210	3.40±0.05	2.75±0.05	8.0±0.10	1.75±0.05	3.50±0.05	0.75±0.05	4.00±0.10	4.00±0.10	2.00±0.05	1.60±0.10
Embossed	2010	5.45±0.10	2.85±0.10	12.00±0.10	1.75±0.10	5.50±0.05	1.00 +0.20, -0	4.00±0.10	4.00±0.10	2.00±0.05	1.50 +0.1, -0
	2512	6.65±0.10	3.40±0.10	12.00±0.10	1.75±0.10	5.50±0.05	1.00 +0.20, -0	4.00±0.10	4.00±0.10	2.00±0.05	1.50 +0.1, -0

### PEEL BACK FORCE AND DIRECTION DIAGRAM

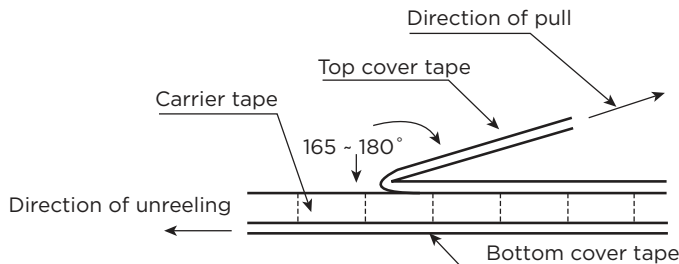

Peel back force and direction of peel back angle should follow EIA481-1-A. Peel back force should be between 0.1N - 1.3N and peel back angle of 165° - 180°.

**ENVIRONMENTAL CHARACTERISTICS**

TEST	REQUIREMENT		TEST METHOD
	Tol. ≤0.05%	Tol. >0.05%	
Temperature Coefficient of Resistance (T.C.R.)	As Specified.		<b>MIL-STD-202 Method 304</b> +25/-55/+125/+25°C
Short Time Overload	ΔR±0.05 %	ΔR±0.2%	<b>JIS-C-5201-1 4.13</b> RCWV*2.5 or Max. Overload Voltage whichever is lower for 5 seconds
	ΔR±0.02% for high power rating		
Insulation Resistance	>9999MΩ		<b>MIL-STD-202 Method 302</b> Apply 100VDC for 1 minute
Endurance	ΔR±0.05%	ΔR±0.2%	<b>MIL-STD-202 Method 108A</b> 70±2°C RCWV for 1000 hrs with 1.5 hrs "ON" and 0.5 hrs "OFF"
	0201: ΔR≤(±1%+0.05Ω)		
Damp Heat with Load	ΔR±0.05%	ΔR±0.3%	<b>MIL-STD-202 Method 103B</b> 40±2°C 90-95% R.H. RCWV for 1000 hrs with 1.5 hrs "ON" and 0.5 hrs "OFF"
	ΔR±0.5% for high power rating		
Bending Strength	ΔR±0.05%	ΔR±0.1%	<b>JIS-C-5201-1 4.33</b> Bending amplitude 3mm for 10 seconds 2010 / 2512 sizes: 2mm Other sizes: 3mm
Solderability	95% min. coverage		<b>MIL-STD-202 Method 208H</b> 245±5°C for 3 seconds
Resistance to Soldering Heat	ΔR±0.05%	ΔR±0.1%	<b>MIL-STD-202 Method 210E</b> 260±5°C for 10 seconds
Dielectric Withstanding Voltage	By Type		<b>MIL-STD-202 Method 301</b> Max. Overload Voltage for 1 minute
Low Temperature Operation	ΔR±0.05%	ΔR±0.2%	<b>JIS-C-5201-1 4.36</b> 1 hour, -65°C, followed by 45 minutes of RCWV
	ΔR±0.5% for high power rating		
High Temperature Exposure	ΔR±0.5%		<b>MIL-STD-202 Method 108</b> at +155°C for 1000 hrs

RCWV (Rated continuous working voltage) =  $\sqrt{P \cdot R}$  or Max operating voltage whichever is lower

Storage Temperature: 25±3°C; Humidity <80% RH