

THIS DRAWING IS UNPUBLISHED. RELEASED FOR PUBLICATION .1997
 © COPYRIGHT 1997 BY - ALL RIGHTS RESERVED.

REVISIONS					
P	LTR	DESCRIPTION	DATE	DWN	APVD
B2		Released as per ECR-07-030419	17.12.07	SP	TS
B3		Released as per ECR-18-004438	05APR2018	GCM	JB

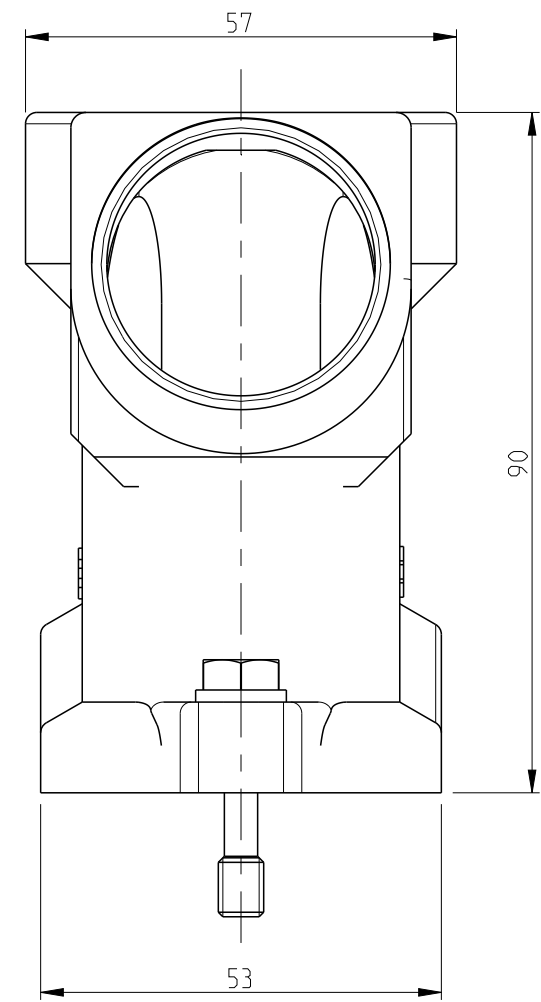

- NOTES
- 1 Material: Housing: Aluminium Diecasting Alloy
Seals: Neoprene
 - 2 Surface: - varnish-grey
Aluminium oxide+
Varnish black
 - 3 Varnish on the inside not necessary
 - 4 Packaging quantity: 5 pieces in a box

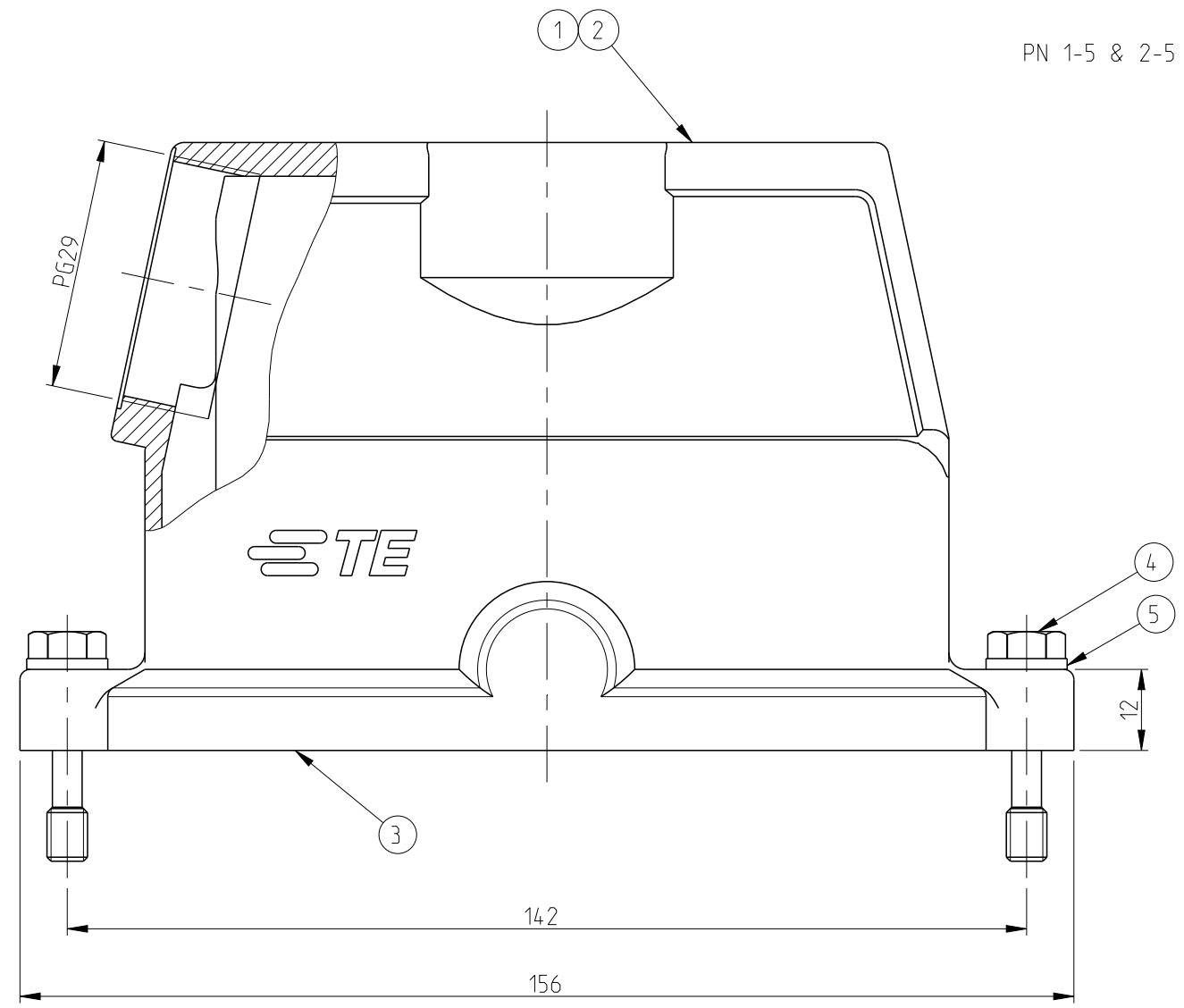
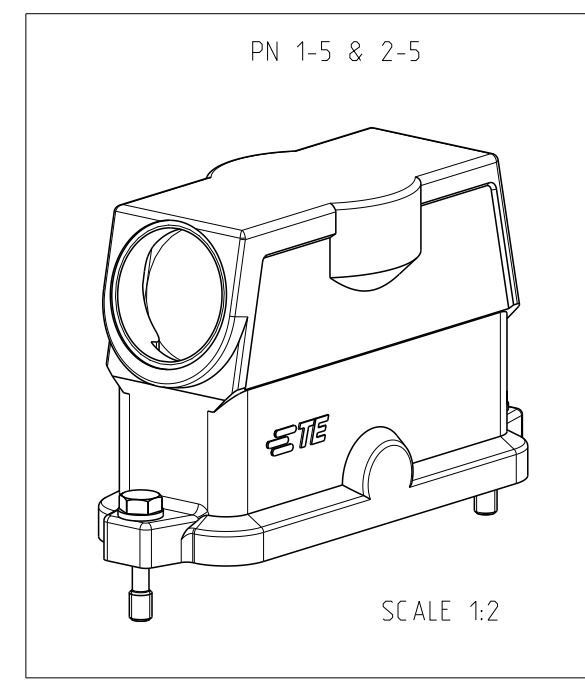

QTY	DESCRIPTION	MATERIAL	SURFACE	COLOR	ITEM NO	REMARKS
2	Spring washer	Stainless steel	Blank		5	
2	Fixing screw	Stainless steel	Blank		4	
1	O-Ring Bg8	Neoprene	-	Black	3	
1	Hood HIP Bg8	Aluminium	Aluminium oxide	Black	2	
1	Hood HIP Bg8	Aluminium	-	Grey	1	
2-5	DESCRIPTION	MATERIAL	SURFACE	COLOR	ITEM NO	REMARKS
ORDERING TEXT						
HIP.24/64.STS.1.29.G						
HIP-K.24/64.STS.1.29.G						

THIS DRAWING IS A CONTROLLED DOCUMENT.		DWN Schneider 02.07.99	STE TE Connectivity		
		CHK Schweiger 02.07.99			
DIMENSIONS: mm		APVD -	NAME Hood Size8 HIP.24/64.STS.1.29.G		
TOLERANCES UNLESS OTHERWISE SPECIFIED: 0 PLC ± 1 PLC ± 2 PLC ± 3 PLC ± 4 PLC ± ANGLES ±		PRODUCT SPEC 108-74030	RESTRICTED TO		
MATERIAL		APPLICATION SPEC 114-74017	SIZE A2	CAGE CODE 100779	DRAWING NO C-1102660
		WEIGHT 540 g	SCALE 1:1 SHEET 1 OF 1 REV B3		
		CUSTOMER DRAWING			