

PART NO.	JLL-101A WIRE	SCALE	1 : 1
DESCRIPTION	SPT-2#18*2C 60C	UNIT:	mm
DWG No.	800-1808-0-SPT2-BL-0008F		

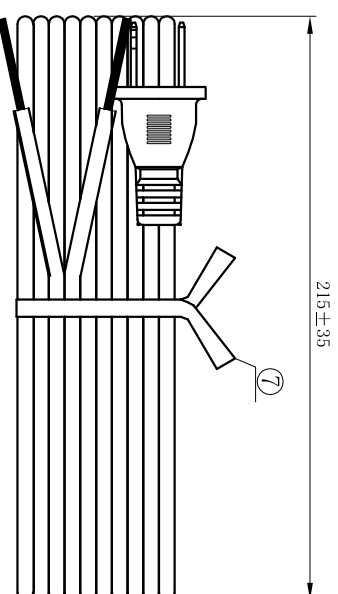

NOTES:
CONDUCTOR CONSTRUCTION(N/mm):
41/0.16AS

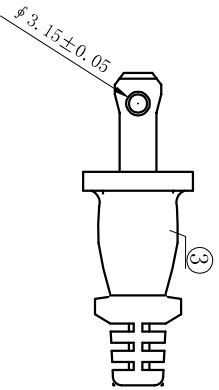
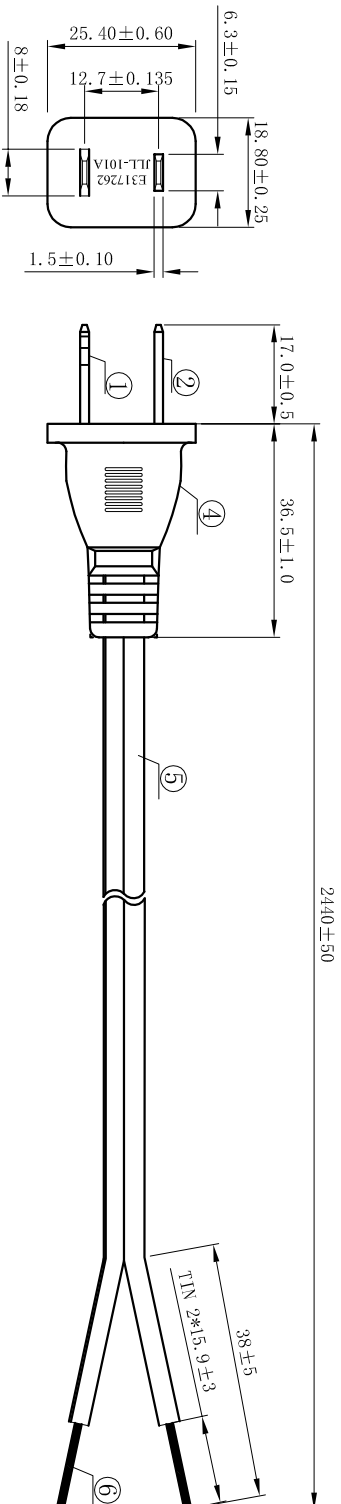

- TESTING:
- 1) 100% OPEN & SHORT TESTING
 - 2) INSULATION RESISTANCE: 100M ohm (min)
 - 3) VOLTAGE: DC500V/1min
 - 4) ROHS COMPLIANT

Printing the contents of wire The use of printing ink replenish Wire

E243711 (UL) SPT-2 2 X 18AWG(0.82mm²) VW-1 60°C 300V CSA 228191 SPT-2 2 X 18AWG(0.82mm²) FT2 60°C 300V JINJIANJI -1P-

NO.	SPECIFICATION	COLOUR	MATERIAL	AMOUNT
①	Terminal polarity 98662	Silver	Cu	1P
②	Non-polar terminal 98661	Silver	Cu	1P
③	Model aircraft 8661AN-2P	WHITE	PBT	1PCS
④	Plug JLL-101A	BLACK	PVC Cu	1PCS
⑤	Wire SPT-2 18AWG/2C 60°C	BLACK	PVC Cu	1PCS
⑥	Tin	Silver	Article tin	2PCS
⑦	Ties	BLACK		1PCS

REV	DATE	DESCRIPTION	SYMBOL

DRAWN/DATE	CHECKED/DATE
CAI/10.05.10	GONG/11.05.13