

REVISIONS					
P	LTR	DESCRIPTION	DATE	DWN	APVD
J		PKG IS CHANGED FROM BOX TO TRAY	18JAN2018	RK	PS
J1		PART STATUS UPDATED	20OCT2021	SCB	SS

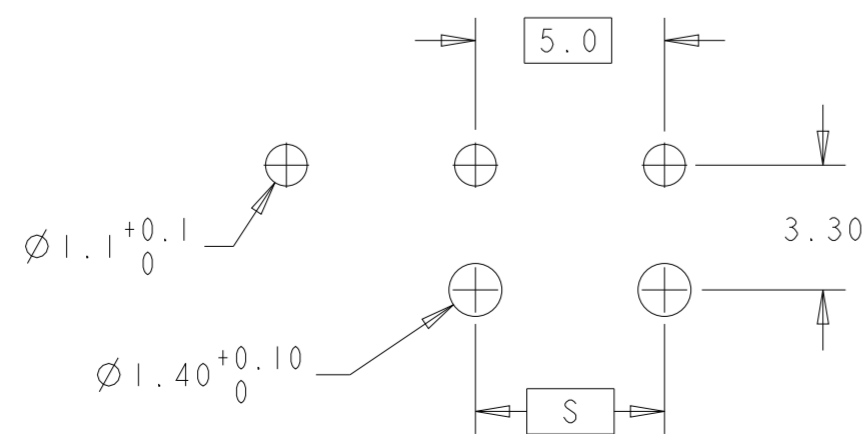
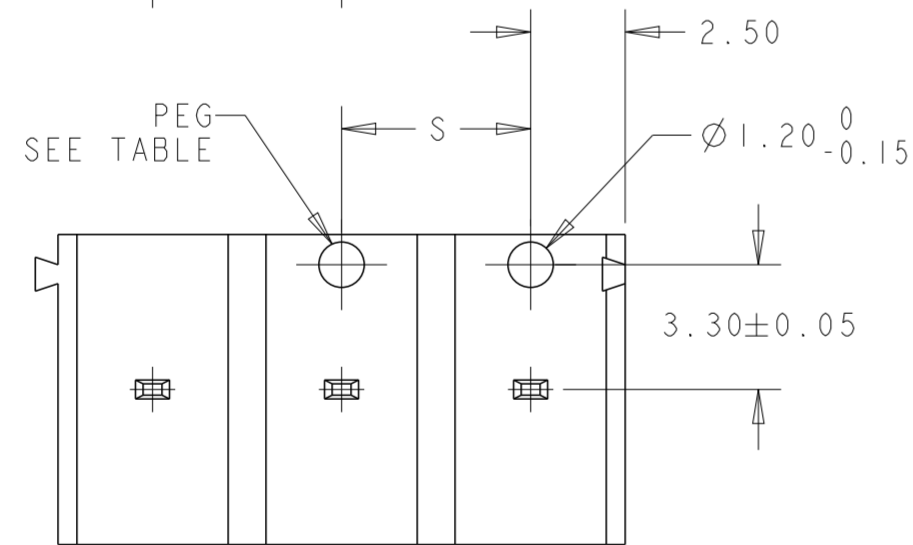
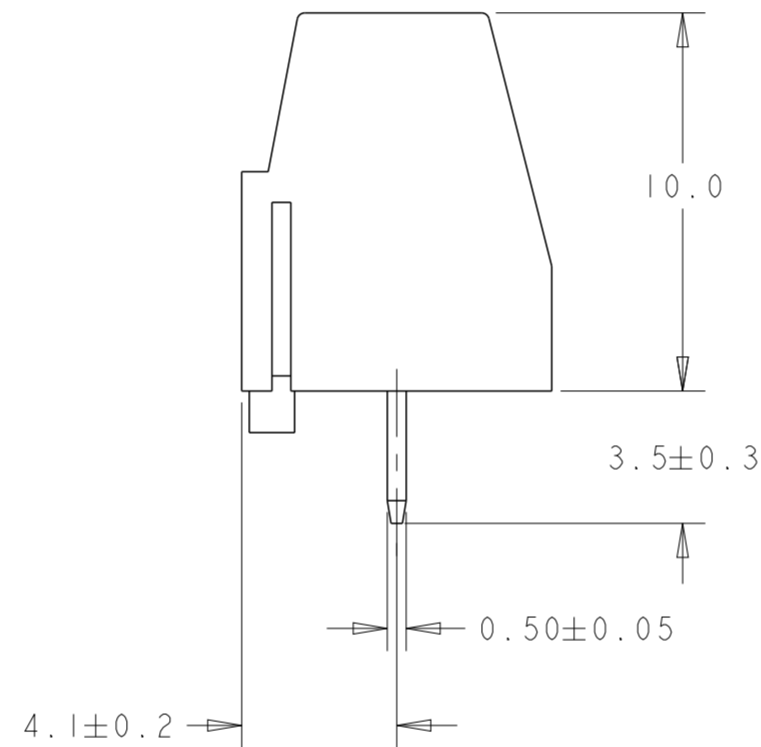
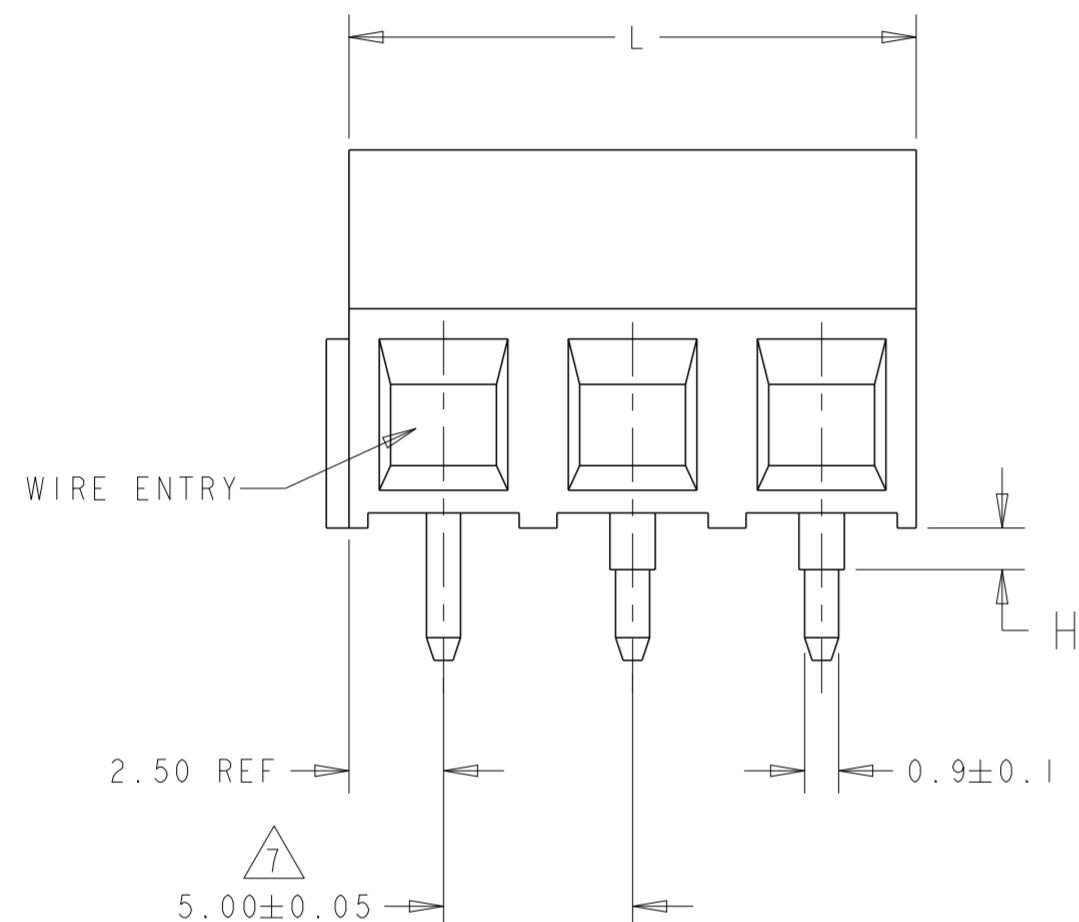
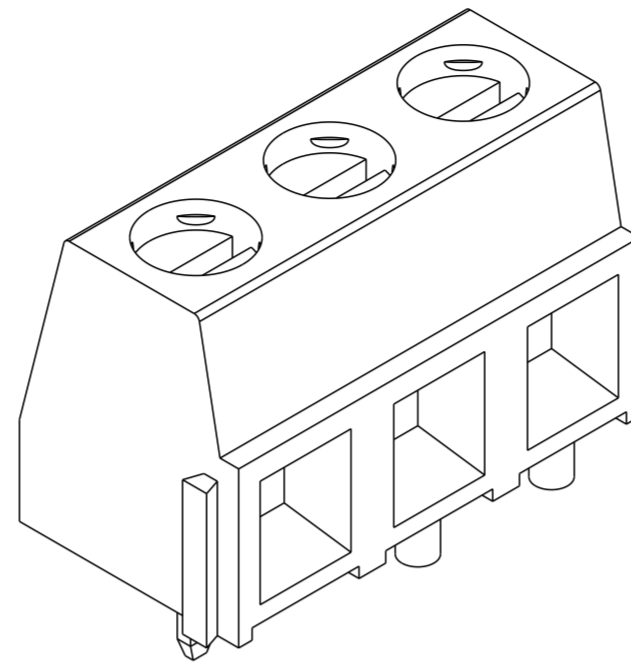
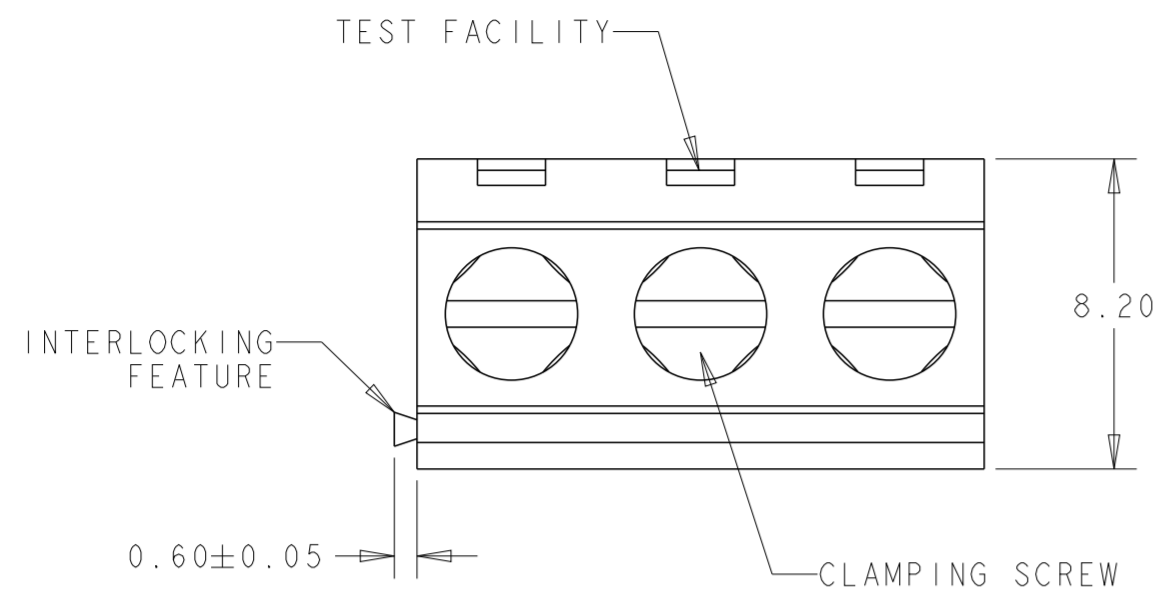

RECOMMENDED PC BOARD LAYOUT

OBSOLETE	-	-	-	SEE SHEET 2	10.0	2	3-1986874-2
	-	-	-	SEE SHEET 2	55.0	11	1-1986874-1
	-	-	-	SEE SHEET 2	10.0	2	1986874-2
	1	N/A	3.5	-	35.0	7	3-282836-7
	1	N/A	3.5	SEE SHEET 2	15.0	3	3-282836-5
	1	N/A	3.5	-	30.0	6	3-282836-4
	1	N/A	3.5	-	25.0	5	3-282836-3
	1	N/A	3.5	-	20.0	4	3-282836-2
OBSOLETE	1	N/A	3.5	-	10.0	2	3-282836-1
	1	N/A	3.5	-	40.0	8	3-282836-0
OBSOLETE	1	N/A	3.5	SEE SHEET 2	45.0	9	2-282836-8
	0	N/A	N/A	SEE SHEET 2	30.0	6	2-282836-7
OBSOLETE	0	N/A	N/A	-	125.0	25	2-282836-6
	0	N/A	N/A	-	120.0	24	2-282836-5
	0	N/A	N/A	-	115.0	23	2-282836-4
	0	N/A	N/A	-	110.0	22	2-282836-3
OBSOLETE	0	N/A	N/A	-	105.0	21	2-282836-2
	0	N/A	N/A	-	100.0	20	2-282836-1
	0	N/A	N/A	-	95.0	19	2-282836-0
	0	N/A	N/A	-	90.0	18	1-282836-9
	0	N/A	N/A	-	85.0	17	1-282836-8
	0	N/A	N/A	-	80.0	16	1-282836-7
	0	N/A	N/A	-	75.0	15	1-282836-6
	0	N/A	N/A	-	70.0	14	1-282836-5
	0	N/A	N/A	-	65.0	13	1-282836-4
	0	N/A	N/A	SEE SHEET 2	10.0	2	1-282836-3
	0	N/A	N/A	-	60.0	12	1-282836-2
	0	N/A	N/A	-	55.0	11	1-282836-1
	0	N/A	N/A	-	50.0	10	1-282836-0
	0	N/A	N/A	-	45.0	9	282836-9
	0	N/A	N/A	-	40.0	8	282836-8
	0	N/A	N/A	-	35.0	7	282836-7
0	N/A	N/A	-	30.0	6	282836-6	
0	N/A	N/A	-	25.0	5	282836-5	
0	N/A	N/A	-	20.0	4	282836-4	
0	N/A	N/A	-	15.0	3	282836-3	
0	N/A	N/A	-	10.0	2	282836-2	
2	5.0	1.1	-	10.0	2	282836-1	
QTY	S	H					
PEG				MARKING	L	NO OF POSN	PART NUMBER

THIS DRAWING IS A CONTROLLED DOCUMENT.

DWN S. WELDON 28SEP2007
CHK C. RICHARD 28SEP2007
APVD C. RICHARD 28SEP2007

TE Connectivity

NAME: TERMINAL BLOCK, PCB MOUNT, SIDE WIRE ENTRY, STACKING WITH INTERLOCK, 5.00mm PITCH

SIZE: A2 CAGE CODE: 00779 DRAWING NO: C-282836

RESTRICTED TO: -

MATERIAL: 1 TOLERANCES UNLESS OTHERWISE SPECIFIED: 0 PLC ±0.2, 1 PLC ±0.2, 2 PLC ±0.15, 3 PLC ±0.000, 4 PLC ±0.0000 ±2° ANGLES FINISH: 1

APPLICATION SPEC: -

WEIGHT: -

CUSTOMER DRAWING SCALE: 5:1 SHEET: 1 OF 3 REV: J1

P	LTR	DESCRIPTION	DATE	DWN	APVD

NOTES:

- 1 MATERIAL AND FINISH:
HOUSING: PA 6-6, UL 94V-0 RATED, COLOR: GREEN.
CLAMP: BRASS, NICKEL PLATED.
TERMINAL: BRASS, TIN PLATED.
CLAMPING SCREW: M3, BRASS, NICKEL PLATED.
- 2 MECHANICAL PROPERTIES
WIRE STRIPPING LENGTH : 5-6 mm
MIN. PC BOARD HOLES DIAMETER : 1.1mm
MAX. PC BOARD THICKNESS : 2.4mm
RECOMMENDED TORQUE FOR SCREW : 0.5 Nm.
- 3 ELECTRICAL PROPERTIES
WIRE RANGE : 16-30 AWG
MAX. VOLTAGE : 300 V
MAX CURRENT : 13.5 A
CONTACT RESISTANCE : <15 m Ohm
INSULATION RESISTANCE : >1000 M Ohm (500V DC)
- 4 END-TO-END STACKABLE W/INTERLOCK WITHOUT LOSS OF CENTERLINE SPACING.
- 5 PACKED IN TRAY.
- 6 RECOGNIZED UNDER THE COMPONENT PROGRAM OF UNDERWRITERS LABORATORIES INC. FILE NO E60677.
- 7 NOT CUMULATIVE TOLERANCE.
- 8 INK MARKING, WHITE COLOR, UNLESS OTHERWISE SPECIFIED. NUMERICAL SEQUENCE FROM LEFT TO RIGHT, UNLESS OTHERWISE SPECIFIED.
- 9 OPERATING TEMPERATURE RANGE: -40°C TO +110°C
- 10 INK MARKING, BLACK COLOR

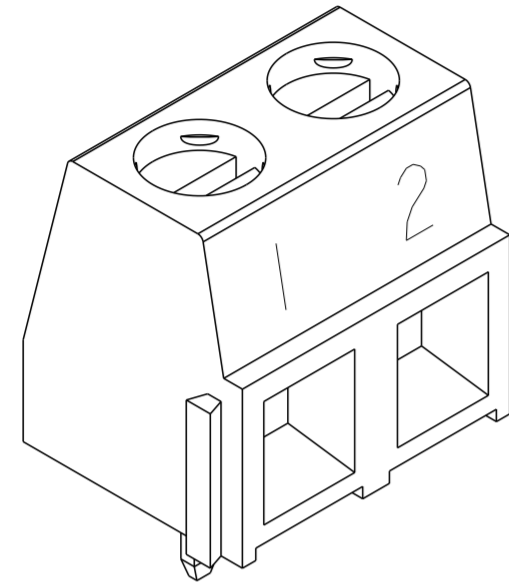

1-282836-3 AS SHOWN

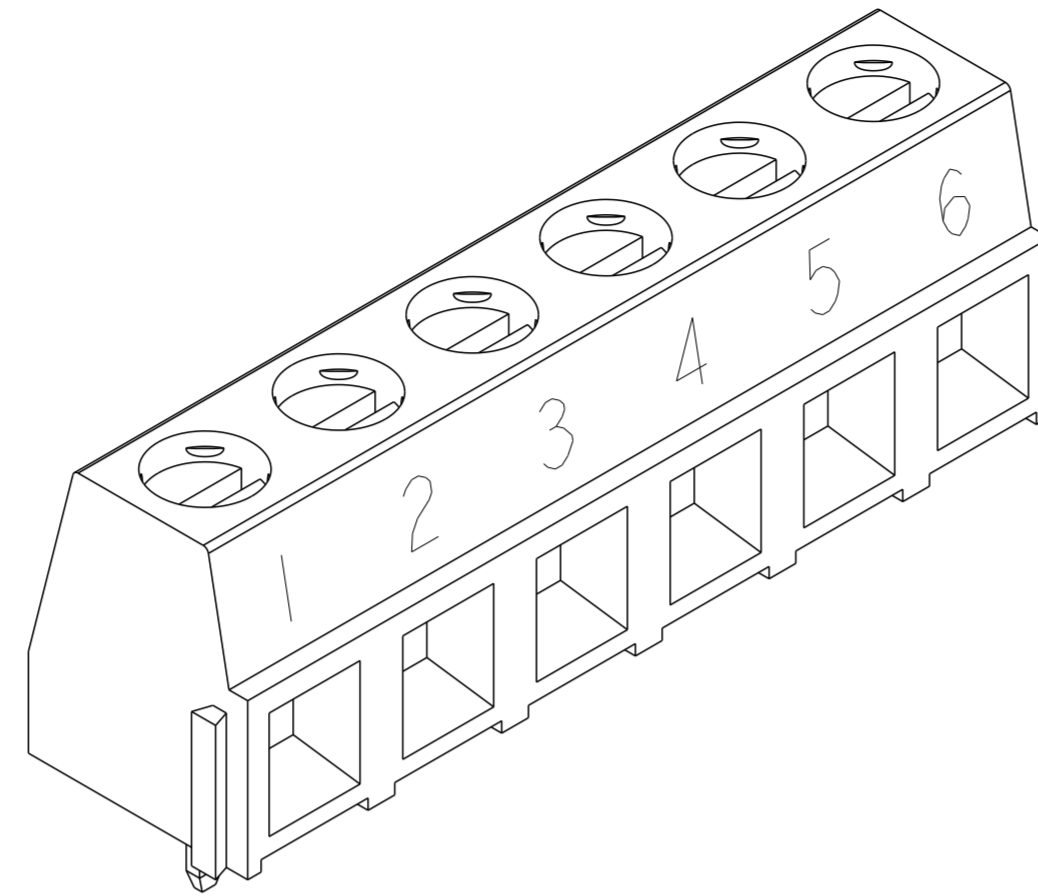

OBSOLETE ~~2-282836-7~~ AS SHOWN

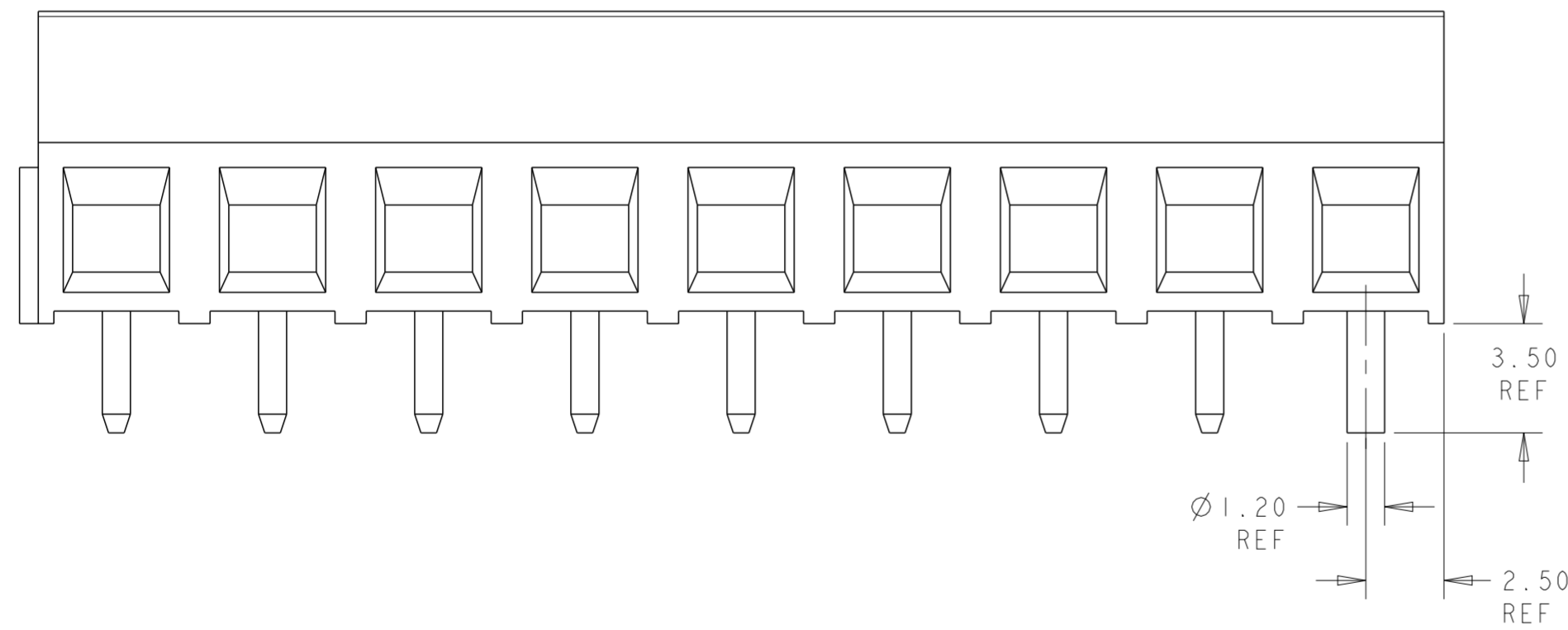

2-282836-8 AS SHOWN

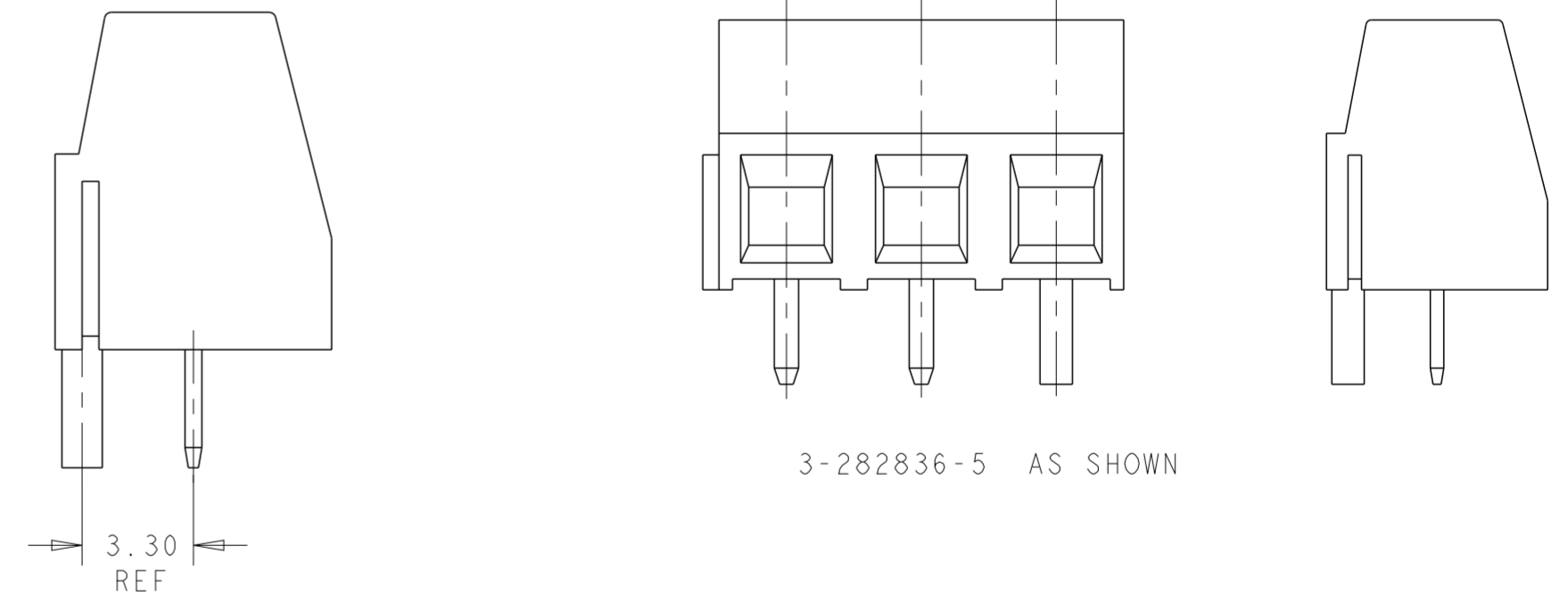

3-282836-5 AS SHOWN

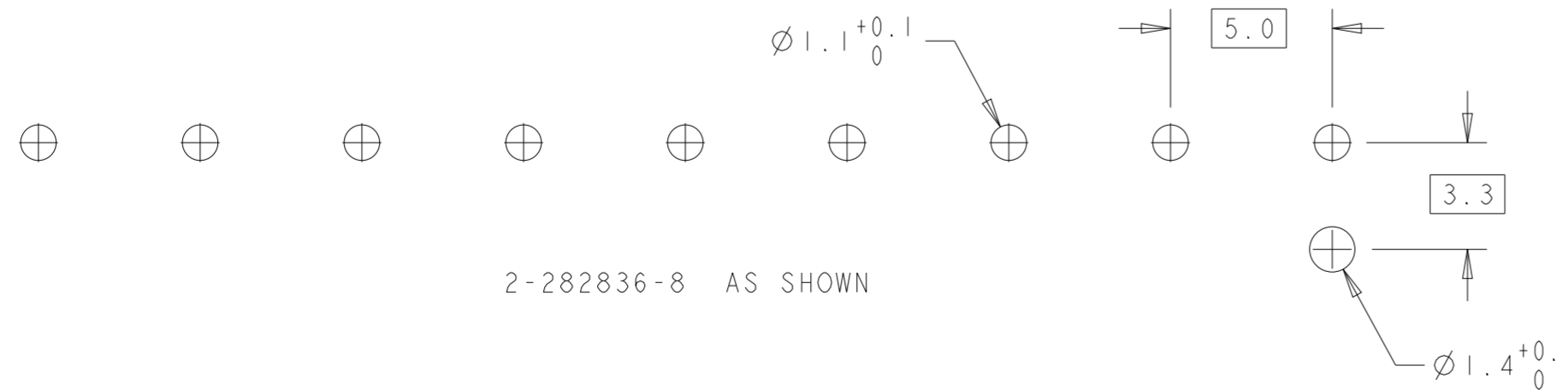

THIS DRAWING IS A CONTROLLED DOCUMENT.		DWN S. WELDON 28SEP2007	TE Connectivity	
DIMENSIONS: mm		CHK C. RICHARD 28SEP2007		
TOLERANCES UNLESS OTHERWISE SPECIFIED:		APVD C. RICHARD 28SEP2007	NAME TERMINAL BLOCK, PCB MOUNT, SIDE WIRE ENTRY, STACKING WITH INTERLOCK, 5.00mm PITCH	
0 PLC ± 1 PLC ±0.2 2 PLC ±0.15 3 PLC ±0.000 4 PLC ±0.000		PRODUCT SPEC -	SIZE A200779	
ANGLES ±2°		APPLICATION SPEC -	CAGE CODE C-282836	
FINISH		WEIGHT -	DRAWING NO C-282836	
MATERIAL		CUSTOMER DRAWING	RESTRICTED TO -	
		SCALE 5:1	SHEET 2 OF 3	
				REV J1

REVISIONS

P	LTR	DESCRIPTION	DATE	DWN	APVD

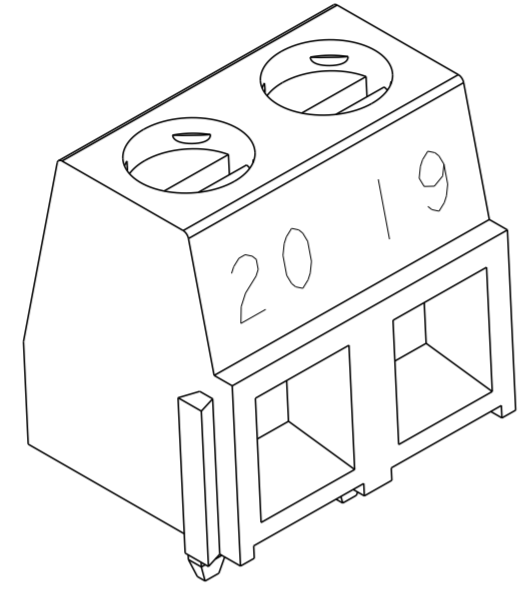

~~3-1986874-2~~ AS SHOWN

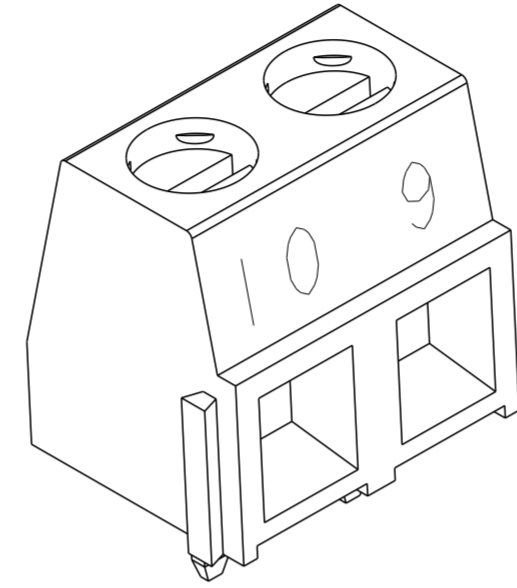

~~1-986874-2~~ AS SHOWN

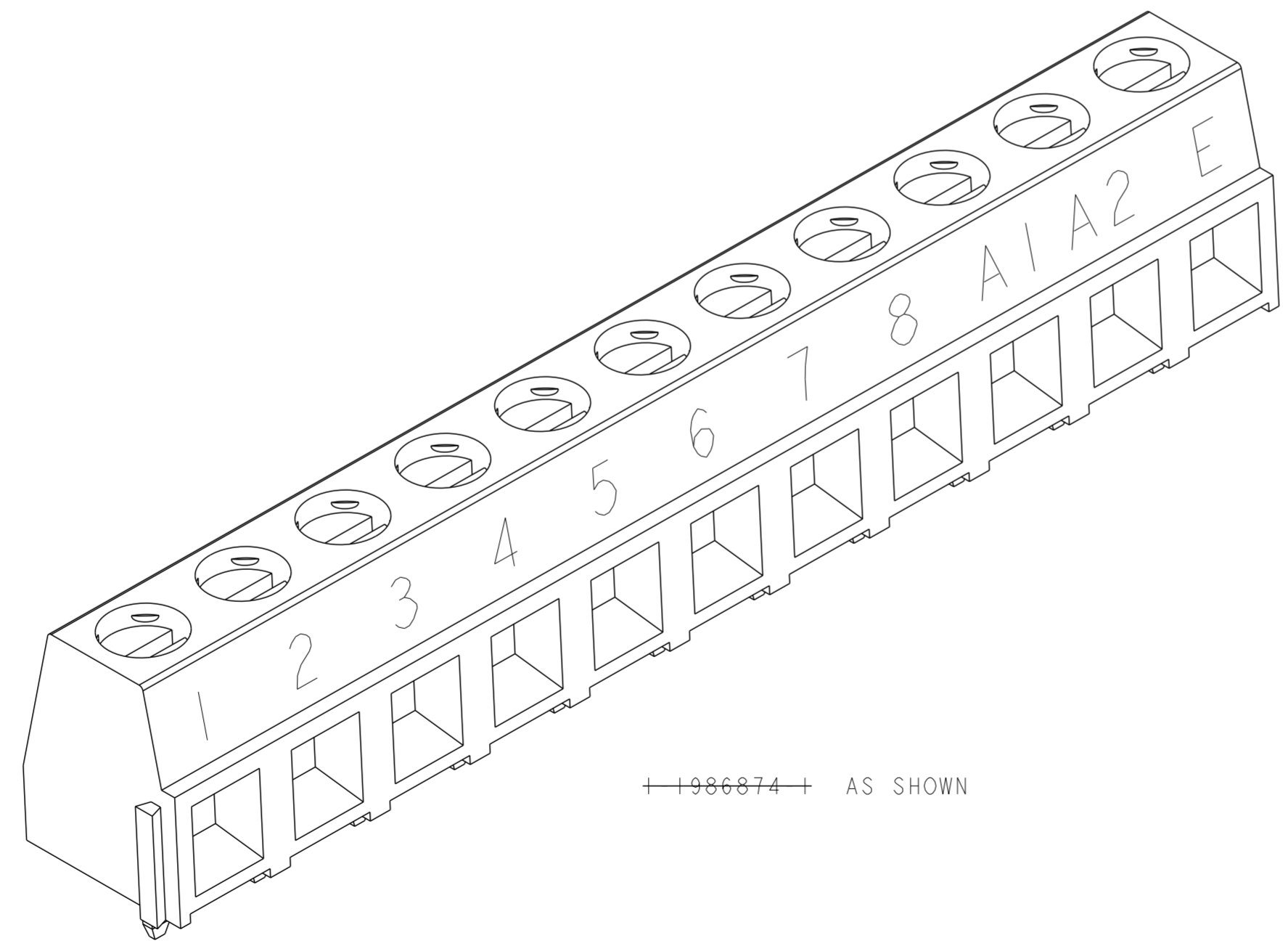

~~1-1986874-1~~ AS SHOWN

THIS DRAWING IS A CONTROLLED DOCUMENT.		DWN S. WELDON 28SEP2007	 TE Connectivity	NAME TERMINAL BLOCK, PCB MOUNT, SIDE WIRE ENTRY, STACKING WITH INTERLOCK, 5.00mm PITCH		
DIMENSIONS: mm		CHK C. RICHARD 28SEP2007		SIZE	CAGE CODE	DRAWING NO
TOLERANCES UNLESS OTHERWISE SPECIFIED: 0 PLC ± 1 PLC ±0.2 2 PLC ±0.15 3 PLC ±0.000 4 PLC ±0.0000 ANGLES ±2° FINISH		APVD C. RICHARD 28SEP2007		A200779		C-282836
MATERIAL		PRODUCT SPEC - APPLICATION SPEC - WEIGHT -		RESTRICTED TO -		SCALE 4:1 SHEET 3 OF 3 REV J1
CUSTOMER DRAWING						