

Product No	No of Cont	DIM "A"	DIM "B"	DIM "C"	DIM "D"	DIM "E"
10138651-05XXXXLF	50	12.0	13.6	18.0	21.1	15.9

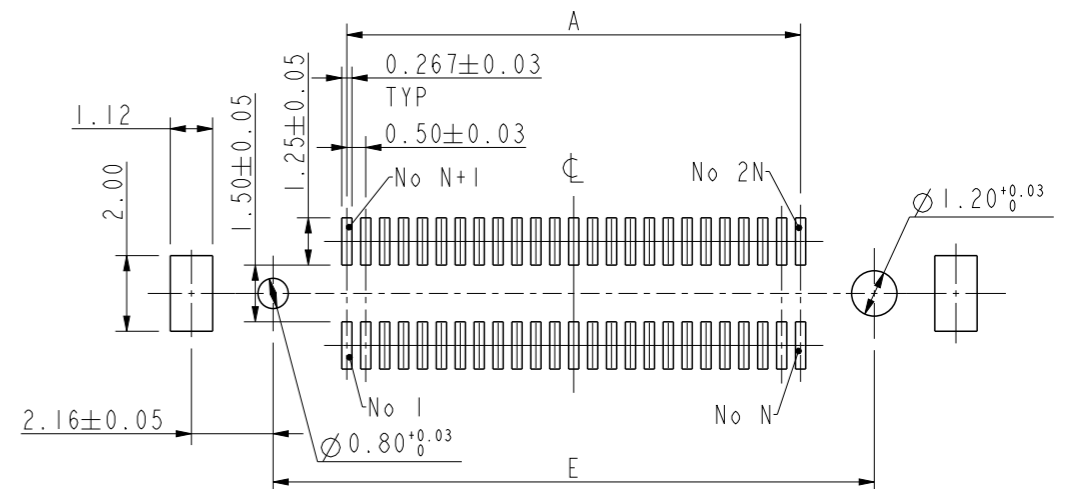
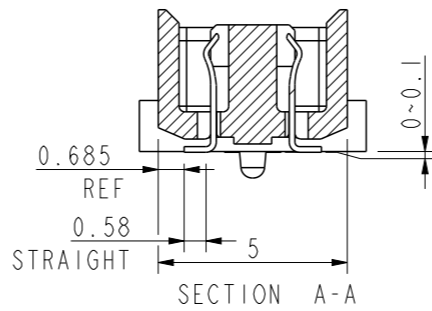
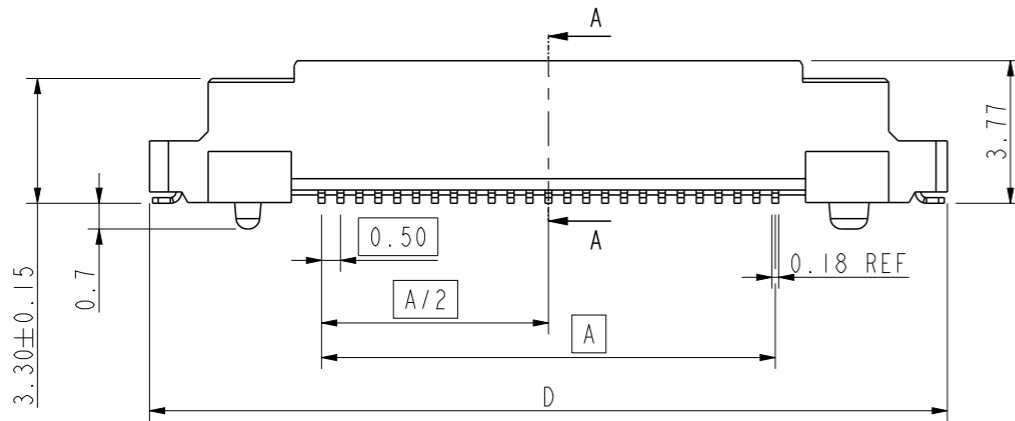
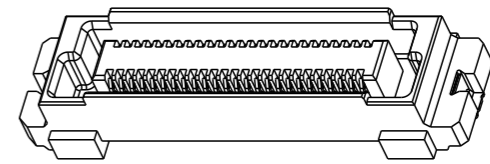
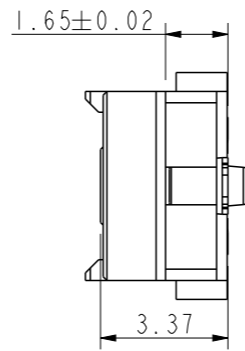
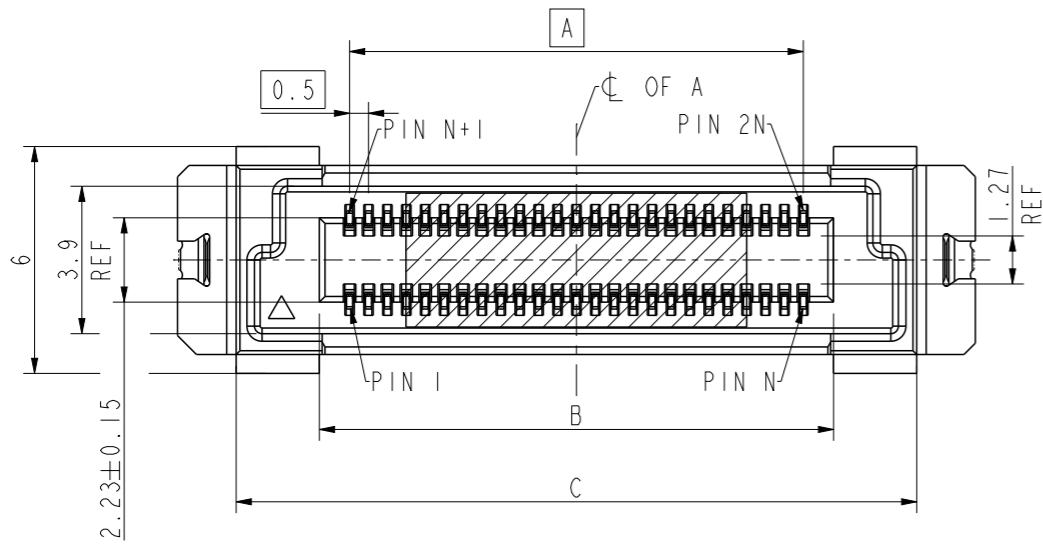

RECOMMENDED PCB LAYOUT FOR 50 POS

NOTE:

- MATERIAL:
  - HOUSING: HIGH TEMPERATURE RESIN, NATURAL, UL94-V0;
  - TERMINAL: COPPER ALLOY;
  - HOLD DOWN: COPPER ALLOY;
  - CAPTON TAPE: POLYIMIDE.
- PLATING:
  - TERMINA: SEE SHEET 2 PLATING OPTION.
  - HOLD DOWN: NI UNDER PLATING, ALL OVER MATTE TIN
- SEE GS-12-1479 FOR PRODUCT SPEC.
- THE HOUSING WILL WITHSTAND EXPOSURE UP TO 260~ PEAK TEMPERATURE FOR 30 SECONDS IN A CONVECTION, INFRA-RED OR VAPOR PHASE REFLOW OVEN.
- ONLY 2X25PIN IS AVAILBLE.
- ALL SOLDER TAIL OF COMPLANARITY: 0.1 MAX

Amphenol  
FCi

© 2016 AFCI

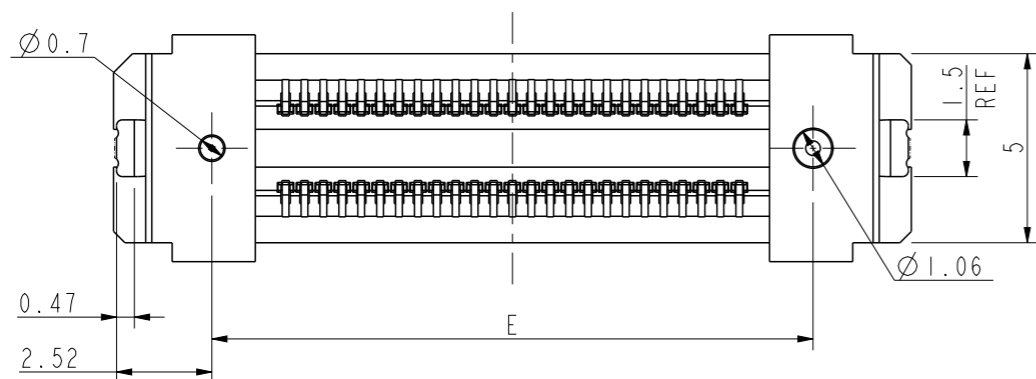

spec ref	-	dr	Li-Qing Lei	2019/07/19	projection	mm	size	A3	scale	3:1
tolerance std	ISO 406 ISO 1101	eng	Bob Gu	2019/08/22			ecn no	-	rel level	Released
TOLERANCES UNLESS OTHERWISE SPECIFIED		chr	-	-						
surface	linear	appr	Tim Yao	2019/08/22	product family	-	dwg no	10138651	rev	A
ISO 1302	angular	0°	±2°	Amphenol FCi	PLUG ASSEMBLY					
					BERGSTAK HS 0.5MM					
					cat. no.	-	Product - Customer Drw		sheet 1 of 2	

PRODUCT NO.  
SEE TABLE

10138651-XX XX XX XX LF

XX	POSITION
05	2X25

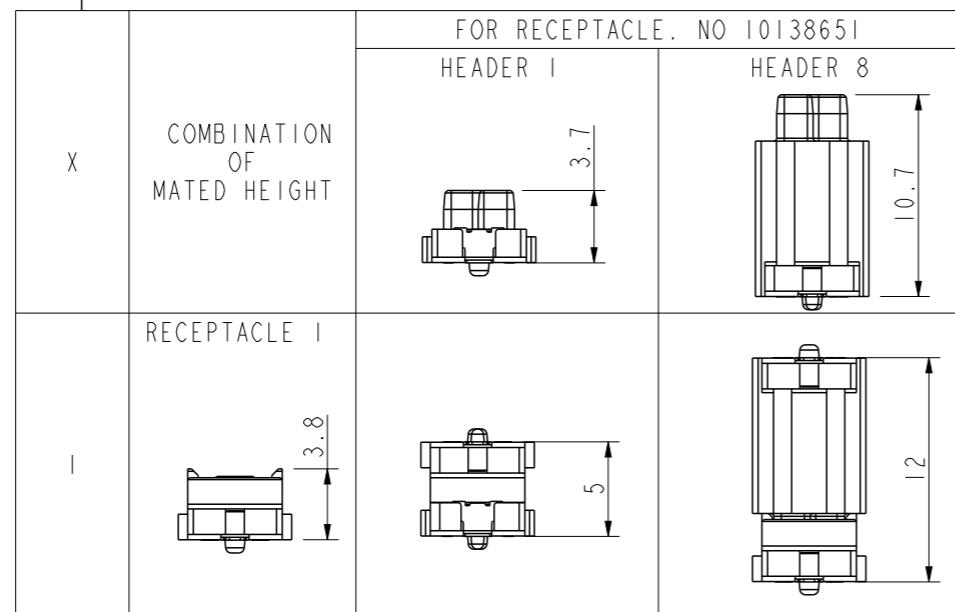

X	PACKAGING
0	TUBE
2	T&R

X	POLARIZATION PEG
0	YES

X	TERMINAL PLATING
2	GOLD 0.127umMIN. ON CONTACT AREA GOLD 0.05umMIN. ON SOLDER TAIL NICKEL UNDERPLATE OVERALL 0.75um MIN
4	GOLD 0.2 umMIN. ON CONTACT AREA PURE TIN 2.5um MIN(LEAD FREE) ON SOLDER TAIL NICKEL UNDERPLATE OVERALL 0.75um MIN
5	GOLD 0.38umMIN. ON CONTACT AREA PURE TIN 2.5um MIN(LEAD FREE) ON SOLDER TAIL NICKEL UNDERPLATE OVERALL 0.75um MIN
6	GOLD FLASH OVER PALLADIUM-NICKEL 0.69um ON CONTACT AREA PURE TIN 2.5um MIN(LEAD FREE) ON SOLDER TAIL NICKEL UNDERPLATE OVERALL 0.75um MIN

Amphenol  
FCi

© 2016 AFCI

spec ref	-	dr	Li-Qing Lei	2019/07/19	projection		size	A3	scale	3:1
tolerance std	ISO 406 ISO 1101	eng	Bob Gu	2019/08/22	mm		ecn no	-	rel level	Released
surface	linear	chr	-	-	product family		rel level	Released		
	angular	appr	Tim Yao	2019/08/22						
	0.X ±0.3	Amphenol FCi		PLUG ASSEMBLY		dwg no	10138651		rev	A
	0.XX ±0.10			BERGSTAK HS 0.5MM						
	0.XXX ±0.05									
ISO 1302	0° ±2°									
				cat. no.	Product - Customer Drw			sheet 2 of 2		